

SiGen Gateway (TP AU, HomeMax TP CN) Installation Guide

Version: 02
Part Number: 3101000019
Release date: 2024-11-30

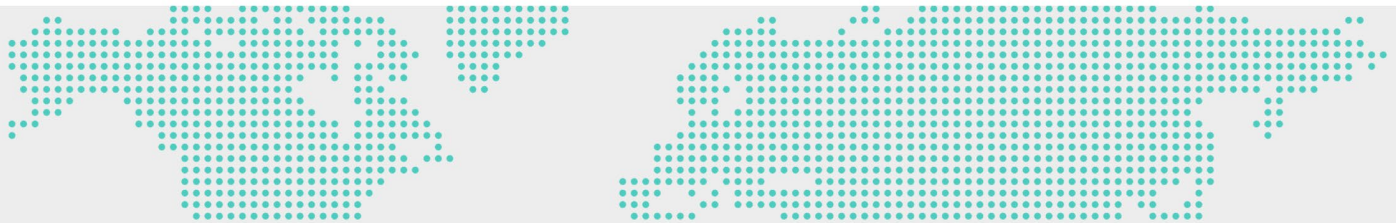

⚠ Caution

- Only trained or qualified persons with electrical engineering knowledge can work directly on the equipment.
- Operators should be familiar with national and local laws, regulations, and standards, and the compositions and operating principles of relevant systems.
- Before operations, please carefully read operating requirements and precautions in this document and Important Notice. Any equipment damage caused by improper operation will not be covered under warranty.

1 Product Description

1.1 Appearance and Dimensions

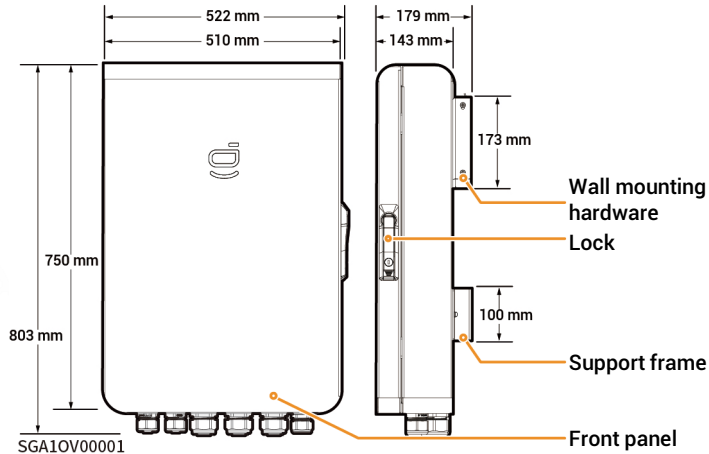

1.2 Port Description

Bottom view

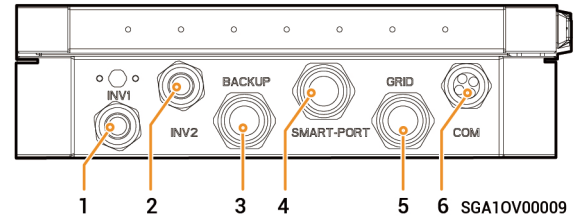

S/N	Name	Marking
1	Wire-in port of inverter 1	INV1
2	Wire-in port of inverter 2	INV2
3	Wire-in port of backup household loads	BACKUP
4	Wire-in port for smart loads/diesel generator	SMART-PORT
5	Wire-in port of power grid	GRID
6	Wire-in port of communication	COM

Interior view

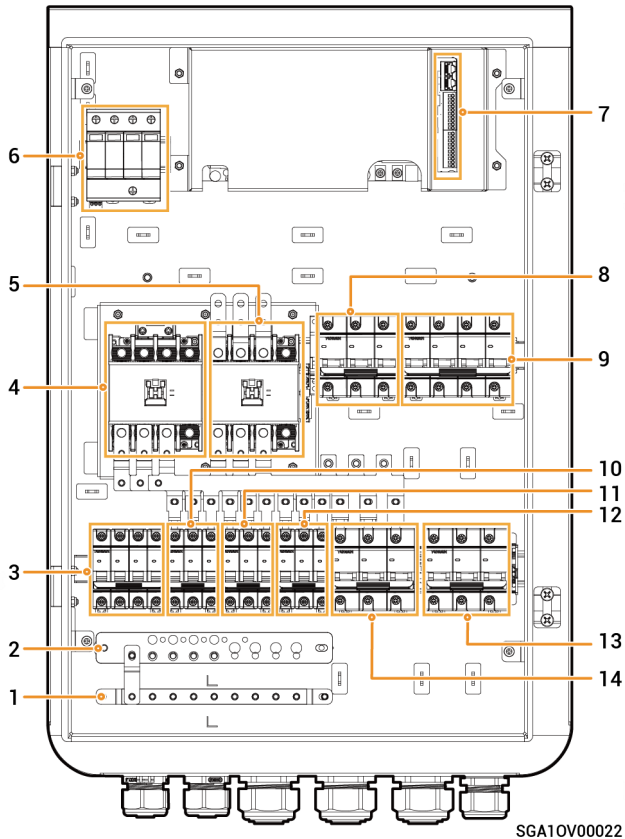

No.	Label	Description
1	-	Grounding copper busbar
2	-	N-line copper busbar
3	QF7	Surge protective device switch
4	KM2	Diesel generator contactor
5	KM1	Grid contactor
6	SPD	Surge protective device
7	-	Communication terminal (connecting to FE or DI communication cable)
8	QS1	Bypass switch
9	QF2	Miniature circuit breaker (connecting to a smart load ^[1] /diesel generator)
10	QF3	Miniature circuit breaker (connecting to a three-phase inverter in a power range of 17.0 kW to 30.0 kW)
11	QF4	Miniature circuit breaker (connecting to a three-phase inverter in a power range of 17.0 kW to 30.0 kW)
12	QF5	Miniature circuit breaker (connecting to a three-phase inverter in a power range of 5.0 kW to 15.0 kW)
13	QF1	Miniature circuit breaker (connecting to the power grid)
14	QF6	Miniature circuit breaker (connecting to a household load)

Note [1]:

- All the power equipment in the owner's home can be connected as smart loads.
- To ensure that this product maximizes the benefits to users, it is recommended that the high-power equipment be connected as smart loads (heat pumps, pool heaters, clothes dryers, immersion heaters, etc.), which can be cut off when the energy storage system has low power. Other low-power equipment are connected as household loads (lights, routers, etc.)

⚠ Danger

Please check that all switches are turned off at the factory. Always avoid hot-line work.

2 Inspections Before Installation

- Check whether the components are entirely supplied against the packing list and whether the appearance is in good condition. For any problem, contact your sales representative.
- Parts and accessories supplied with the packing box are personal assets of the owner and must not be taken away from the installation site.
- Check personal protective equipment and installation tools to ensure that they are complete; If not, please make them up.
- Check and ensure the completeness of personal protective equipment and installation tools; replenish if necessary.

Personal Protective Equipment



Safety hat



Goggles



Dust mask



Protective gloves



Insulating gloves



Insulating shoes

Installation Tools



Power drill



Vacuum cleaner



Wire cutter



Crimp tool



Crimping pliers



Wire stripper



Scissors



Cable ties



Heat shrinkable sleeve



Heat gun



Insulated screwdriver set



Insulated sleeve set



Torque socket wrench



Marker

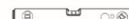

Level



Tape measure



Utility knife

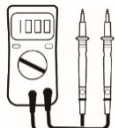

Multimeter



Caution

The specification of installer-provided cables shall meet the cable laws and standards of the countries/regions.

Self-supplied Cables

No.	Cable name		Recommended specification
1	AC cable	Used to connect an inverter	Outdoors five-core copper flexible cable (L1, L2, L3, N, PE) <ul style="list-style-type: none"> • Power: 5.0 kW to 15.0 kW, cross-sectional area of conductor: 4 mm² to 6 mm², cable OD: 10 mm to 21 mm • Power: 17.0 to 20.0 kW, cross-sectional area of conductor: 6 mm² to 10 mm², cable OD: 19 mm to 22 mm • Power: 20.0 to 30.0 kW, cross-sectional area of conductor: 10 mm² to 16 mm², cable OD: 22 mm to 25 mm
2		Used to connect a backup household load	Outdoor five-core copper flexible cable (L1, L2, L3, N, PE) Cross-sectional area of core conductor: 35–50 mm ² ; Outer diameter: 28–32 mm
3		Used to connect to the power grid	
4		Used to connect a diesel generator/smart load (optional)	
5	RJ45 network cable		Outdoor eight-conductor shielded twin-twisted pair cable (EIA/TIA 568B standard network cable) Cross-sectional area of core conductor: 0.13–0.2 mm ² Outer diameter: 4–7.5 mm Cable length: ≤ 100 m ^[1]
6	DI/DO signal cable		Outdoor two-conductor shielded cable Cross-sectional area of core conductor: 0.2–1.5 mm ² Outer diameter: 2–4 mm

Note [1]: The cable length should be limited for good communication. Too long cable degrades the communication effect. FE communication distance: ≤ 100 m.

3 Site Requirements

Tips

- The warranty applies when the equipment has been installed properly for its intended use and in accordance with the operating instructions.
- During actual installation, the selection of installation location should comply with local firefighting, environmental protection regulations, and other relevant laws. The specific installation location planning should be subject to the installer or engineering, procurement, and construction (EPC) contracts.

Installation Environment

- Do not install the equipment in a smoky, flammable, or explosive environment.
- Avoid exposing the equipment to direct sunlight, rain, standing water, snow, or dust. It is suggested to install the equipment in a sheltered place. Take preventive measures in operating areas prone to natural disasters such as floods, mudslides, earthquakes, and typhoons.
- Do not install the equipment in an environment with strong electromagnetic interference.
- The temperature and humidity of the installation environment should meet equipment requirements.
- The equipment should be installed in an area that is at least 500 m away from corrosion sources that may result in salt damage or acid damage. Corrosion sources include but are not limited to seaside, thermal power plants, chemical plants, smelters, coal plants, rubber plants, and electroplating plants.

Installation Location

- Do not tilt the equipment or place it upside down. Ensure that the equipment is horizontally installed.
- Do not install the equipment in areas easily accessible to children.
- Do not install the equipment in a place with fire hazards or is prone to moisturizing.
- The equipment produces sound when it is operating. Please install the equipment in a place with appropriate distance at which there is no impact to daily work and life.
- Do not install the equipment in a sealed, poorly ventilated location without fire protection measures and inaccessible for firefighters.
- The equipment is hot when it is operating. If the equipment is installed indoors, please ensure good indoor ventilation and avoid significant indoor temperature rise by more than 3° C while the equipment is operating. Otherwise, the equipment will be derated.
- Do not install the equipment in mobile scenarios such as recreational vehicles, cruise ships, and trains.
- It is recommended to install the equipment in a location where you can easily access, install, operate, and maintain it, and view the indicator status.
- Do not place the equipment in the vehicle passage when installed in a garage to avoid collisions.

Installation Base

- Do not install the equipment on a flammable base.
- The installation base should meet the load-bearing requirement. Solid brick-concrete structures, concrete walls are recommended.
- The installation base should be flat, and the installation area should meet the installation space requirements.
- No plumbing or electrical alignments are allowed inside the installation base to avoid potential drilling hazards during equipment installation.

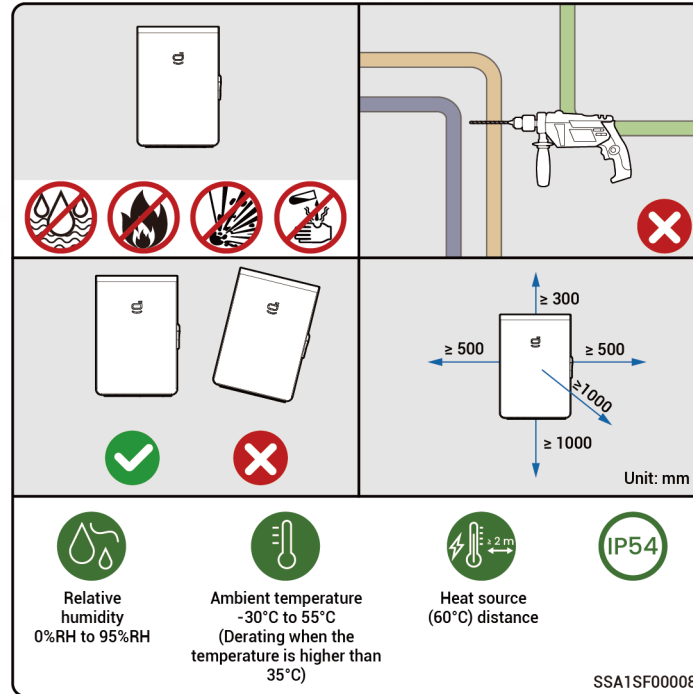

4 Installation

1

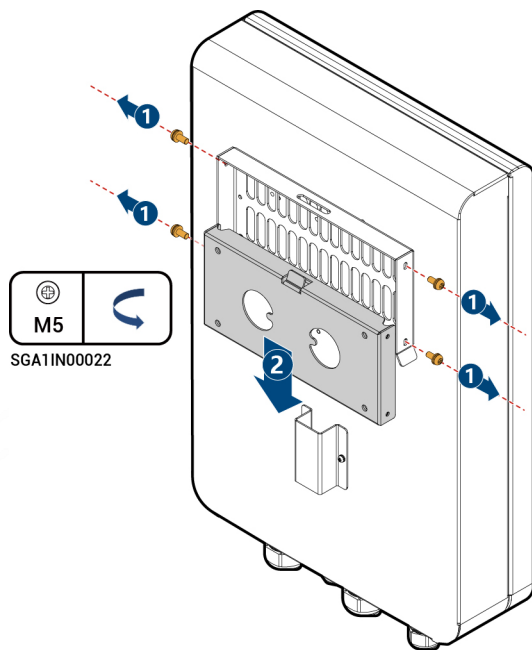

2

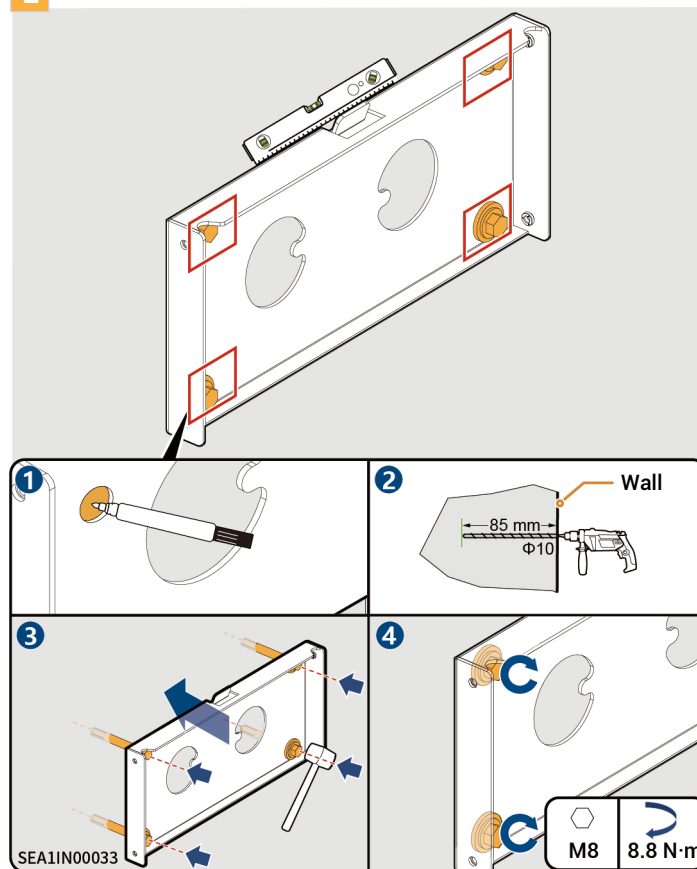

3

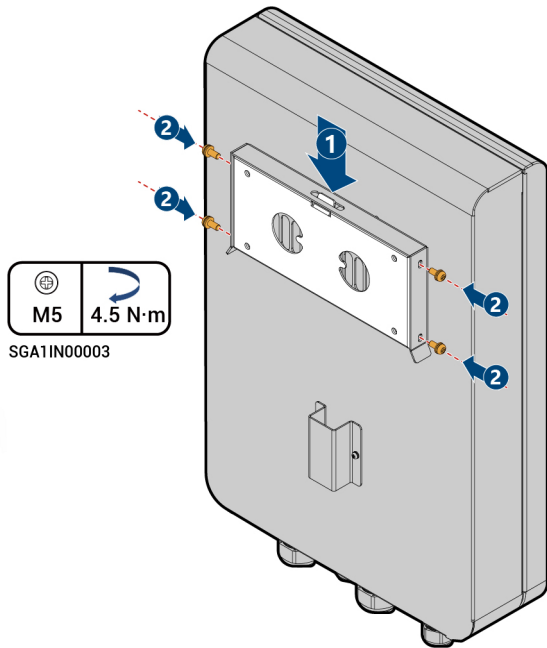

5 Cable Connection

5.1 Recommended Routing

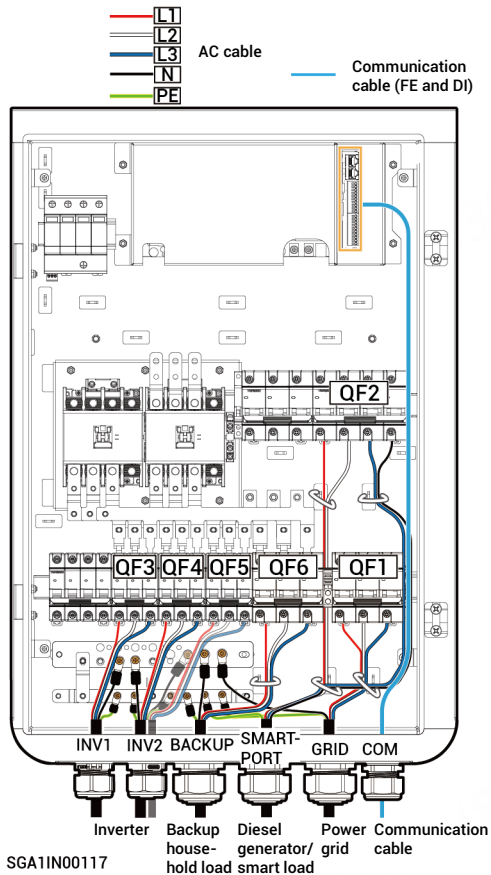

Danger

Do not perform operations on the equipment with power on. Before operation, please make sure all power supplies to the equipment have been disconnected, including but not limited to the grid side, inverter and diesel generator power switches.

Tips

- QF3 and QF4 support the connection of inverters with a power range of 17.0 kW to 30.0 kW, while QF5 supports the connection of inverters with a power range of 5.0 kW to 15.0 kW. Please connect according to the actual requirements.
- Connect cables according to the corresponding labels to prevent personal injury and equipment damage caused by incorrect cable connection.
- To ensure that the inverters, loads, and the Gateway are connected to the common ground point, connect the PE cable.
- The wire color codes in the figure is only for identifying different types of wires. Select proper wires according to your local laws and regulations. The actual wire color codes shall prevail.

5.2 Opening Equipment Door

1

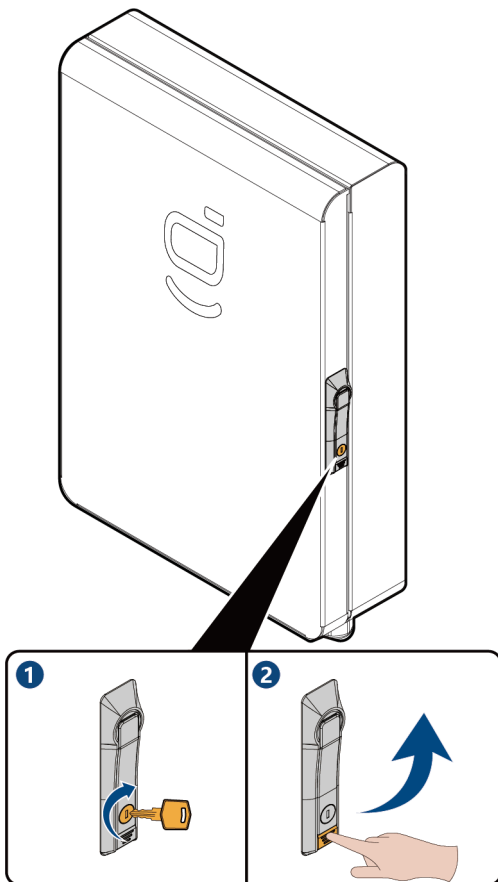

SGA1IN00011

2

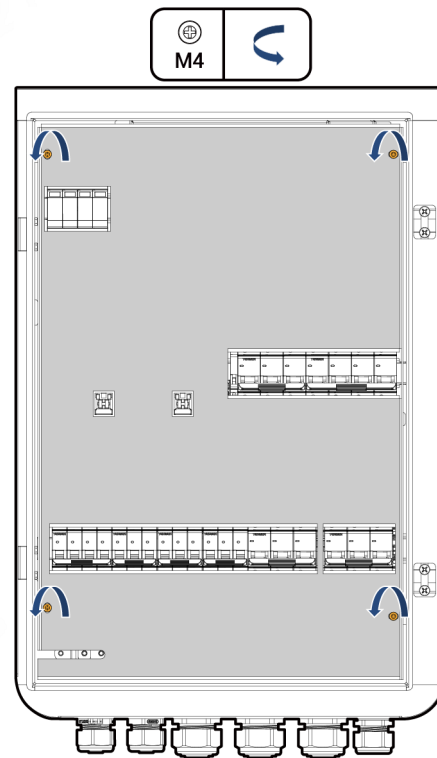

SGA1IN00119

5.3 (Optional) Installing Short-connected Copper Busbar

Tips

If the Gateway serves as the power distribution box at the first stage, you must short-connect the N-line copper busbar to the grounding copper busbar with a short-connected copper busbar. A short-connected copper busbar is not installed in other settings.

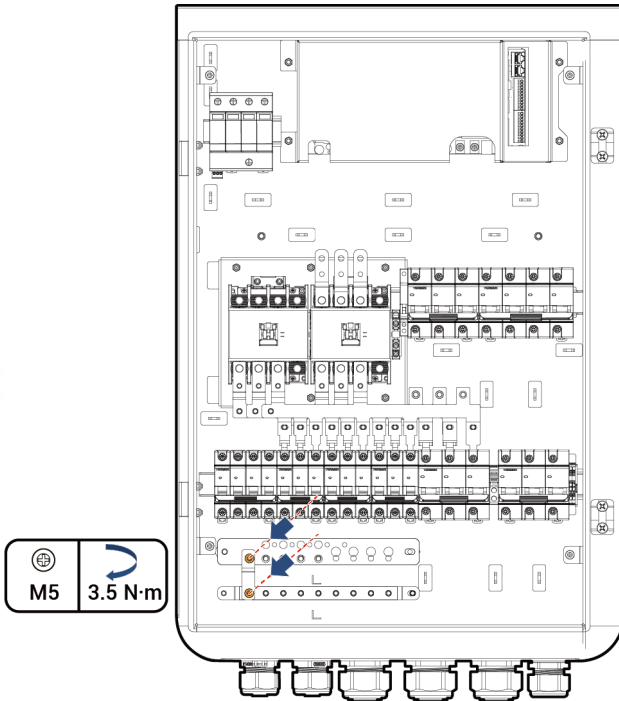

SGA1IN00120

5.4 Connecting Power Grid/Inverter/Backup Household Load

Tips

The method to connect the power grid/inverter/backup household load is the same. This section takes connecting the power grid as an example.

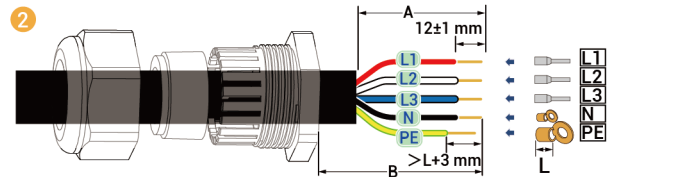
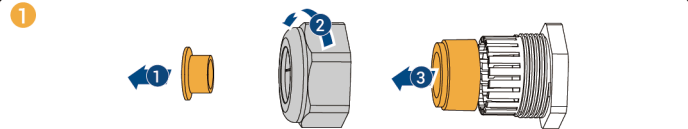

Routing hole --QFX	B (mm)	A (mm)				
		L1	L2	L3	N	PE
GRID--QF1	≥ 250	≥ 190			≥ 200	≥ 160
BACKUP--QF6	≥ 260	≥ 210			≥ 110	≥ 90
INV2--QF5	≥ 240	≥ 190			≥ 100	≥ 80
INV2--QF4	≥ 230	≥ 180			≥ 100	≥ 80
INV1--QF3	≥ 210	≥ 160			≥ 100	≥ 80

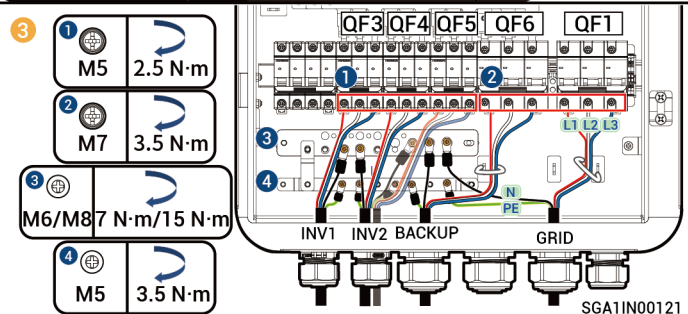

SGA1IN00121

5.5 Connecting Diesel Generator/Smart Load

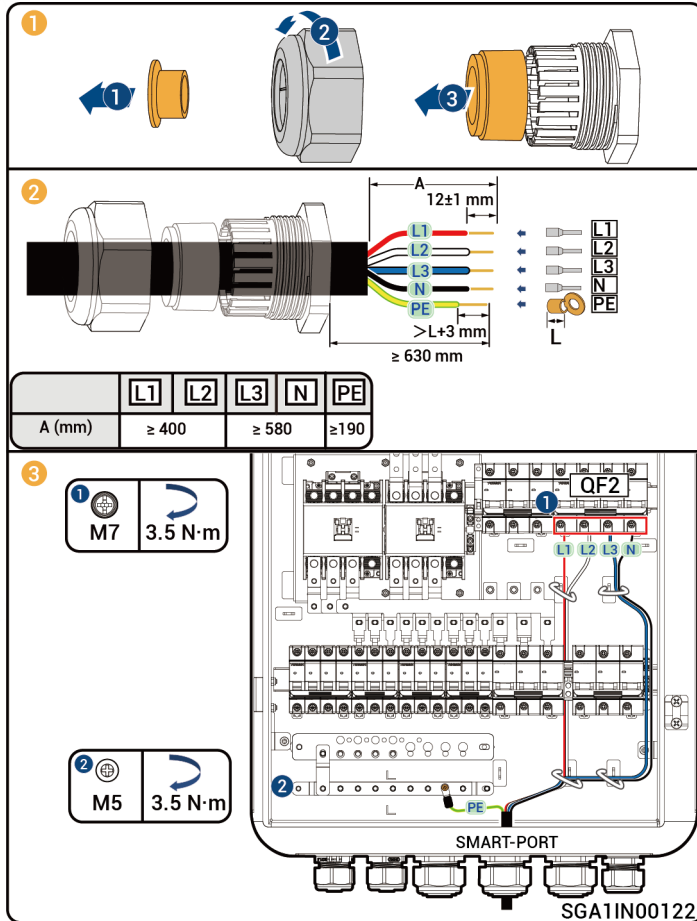

5.6 Connecting Communication Cable

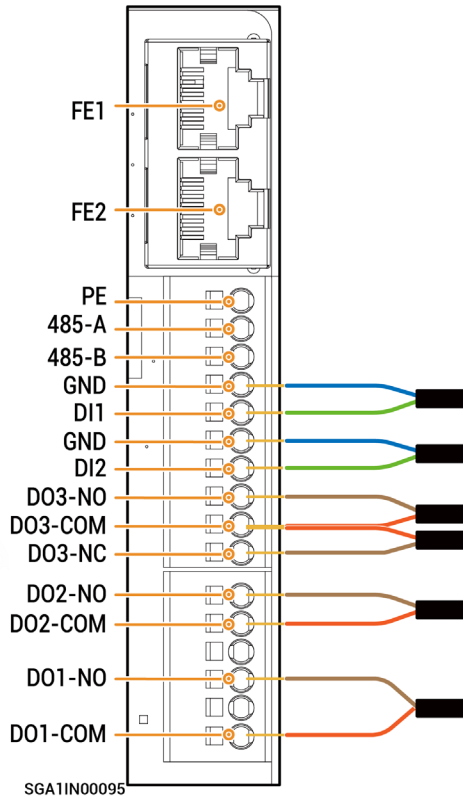

Label		Definition		Description
FE (Network cable interface)	FE1	Fast Ethernet 1		Used to connect an inverter.
	FE2	Fast Ethernet 2		Used to connect an Sigen EV AC Charger, inverter, router and so on.
(Reserved)485 (RS485 interface)	PE	PE signal shielding ground		Used to connect the equipment over RS485.
	485-A	RS485 signal 2_A+		
	485-B	RS485 signal 2_B-		
DI1 (Digital input 1)	GND	Signal GND		<ul style="list-style-type: none"> Universal digital input interfaces. DI1 is used to connect the feedback contact of the bypass switch.
	DI1	Digital input 1		
DI2 (Digital input 1)	GND	Signal GND		<ul style="list-style-type: none"> DI2 can be used to connect the feedback signal of the external Automatic Transfer Switch (ATS) to identify whether the gateway "grid port" is powered by the grid or the generator. Low impedance input (short circuit on ATS relay) indicates the power grid. High impedance input (open circuit on the ATS relay) indicates the diesel generator.
	DI2	Digital input 2		
D03 (Dry contact 3)	-	D03-NO	Digital output 3 - Normal Open	<ul style="list-style-type: none"> Universal digital output interface. D01 has a contact capacity of 250 Va.c./1 A or 30 Vd.c./1 A. D02 and D03 have a contact capacity of 30 Vd.c./1 A. NO/COM is normally open contact and NC/COM is normally close contact. The D03-COM and D03-NC interface can be used for controlling generator start in two-wire start mode.
	GEN (Diesel generator startup)	D03-COM	Digital output 3 - Common	
		D03-NC	Digital output 3 - Normal Close	
D02 (Dry contact 2)	D02-NO	Digital output 2 - Normal Open		
	D02-COM	Digital output 2 - Common		
D01 (Dry contact 1)	-	-		
	D01-NO	Digital output 1 - Normal Open		
	-	-		
	D01-COM	Digital output 1 - Common		

5.6.1 Connecting RJ45 Network Cable

Tips

- Two network ports, one of which is connected to the inverter, and the other is connected to other devices. (for example, Sigen EV AC Charger, inverter, and router)

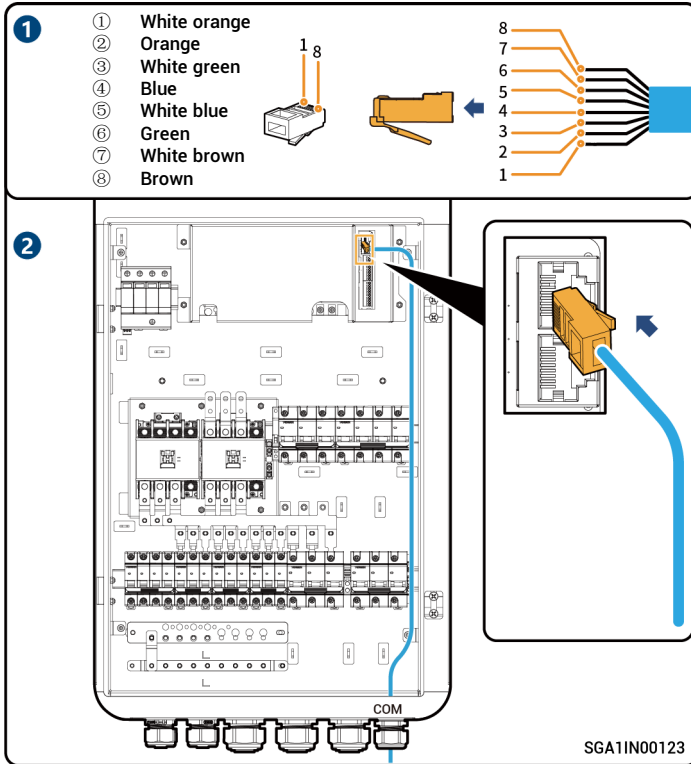

5.6.2 Connecting DI/DO Cable

Tips

The method to connect the DI/DO cable is the same. This section takes connecting the DO cable as an example.

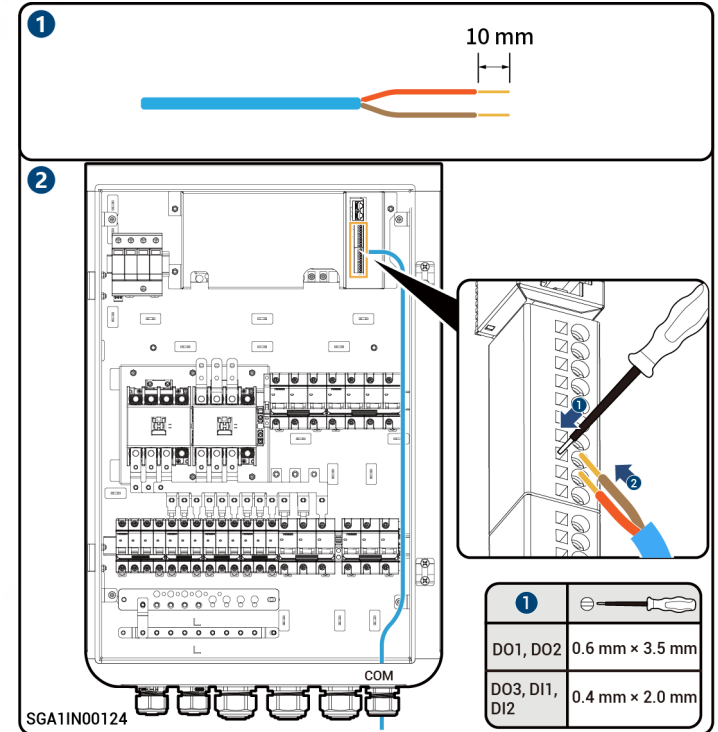

5.7 Post-installation Check

Check the following items against the provided table, tighten routing holes, and install the protective covers.

No.	Check Item
1	The equipment is securely installed.
2	Grounding cable, AC cables, and signal cables are properly connected without omission.
3	Lock screws or terminals are installed in place without any looseness.
4	Cutouts of cable ties are free of burr or sharp edges.
5	No construction residue inside and outside the equipment.

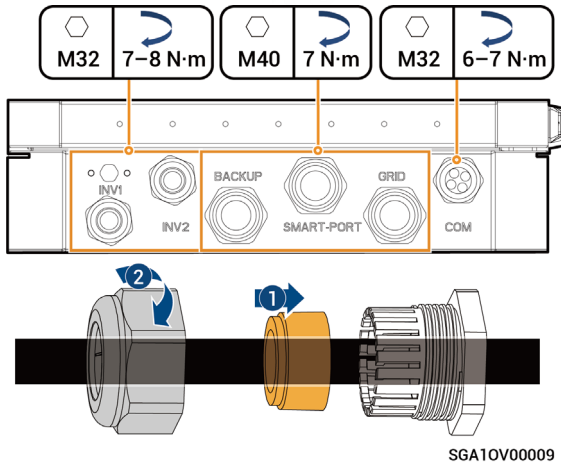

5.8 Installing Inner Panel

Caution

Measure the voltage of the switch QF1 on the power grid side and check that the measured value is within the allowable range. Ensure that the cable is connected properly and install inner panel.

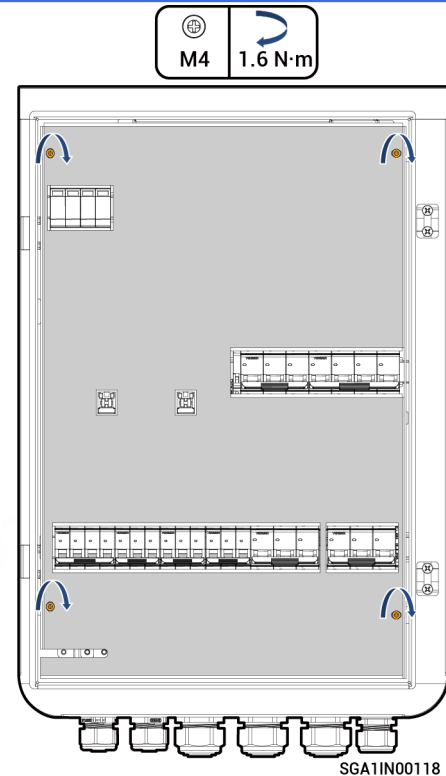

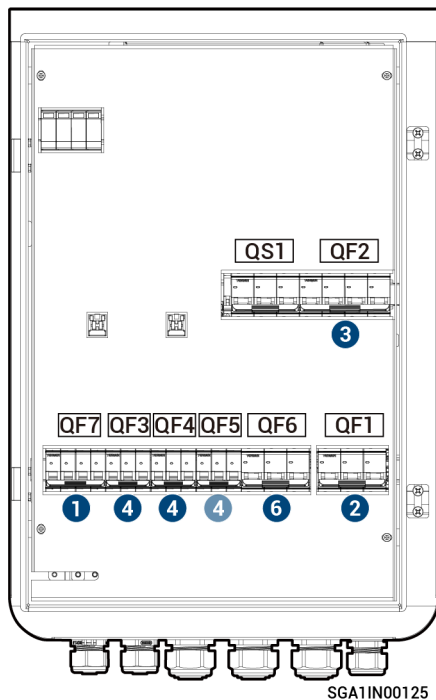

Tips

- Turn on the upstream AC switch.
- There is a risk of electric shock when the Gateway is not grounded.
- If the surge protective device is not turned on, the failure of the surge protective device can damage loads and Gateway.

1

⚠ Caution

Do not turn on the miniature circuit breaker when it is not connected to its corresponding device.

- 1 Turn on the surge protective device switch QF7.
- 2 Turn on the miniature circuit breaker QF1 (connecting to the power grid).
- 3 Turn on the miniature circuit breaker QF2 (connecting to a diesel generator/smart load).
- 4 Turn on the miniature circuit breakers QF3, QF4 or QF5 (connecting to an inverter).
- 5 Wait until inverter is powered on.
- 6 Turn on the miniature circuit breaker QF6 (connecting to a backup household load).

2

Finally, close the equipment door.

⚠ Danger

In normal cases, the bypass switch is turned off.

Sigenergy Technology Co., Ltd.



Website	LinkedIn	YouTube
---------	----------	---------

www.sigenergy.com



Copyright © Sigenergy Technology Co., Ltd. 2024. All rights reserved.

Description in this document may contain predictive statements regarding financial and operating results, product portfolio, new technology, configurations and features of product. Several factors could cause difference between actual results and those expressed or implied in the predictive statements. Therefore, description in this document is provided for reference purpose only and constitutes neither an offer nor an acceptance. Sigenergy Technology Co., Ltd. may change the information at any time without notice.