



# M-ELV Battery Quick Installation Guide

Applicable models: MS-7K-U

## Atmoce Battery Introduction

The ATMOCE MS-7K-U battery is a fully integrated system with a usable energy capacity of 7.0 kWh. It supports both single-phase and three-phase grid systems, offering self-consumption, TOU and grid ancillary services modes that enables homeowners to achieve energy independence by generating and utilizing their energy while participating in grid services.

## Pre-installation Requirements

### a. Grid requirements

ATMOCE battery should connect to a single-phase or a three-phase grid. Measure AC line voltages at the point of connection to confirm that they are within the ranges.

Phase setup	Voltage range	
Single-phase	L to N	184 to 276 Vac
Three-phase	L1, L2, L3 to N	184 to 276 Vac

### b. Tools requirements

Tools: screwdriver, wire stripper, wire crimper, diagonal cutter, torque wrench, electrical drill, marker, hammer, etc. Materials: tie wrap, wago connector, etc.

### c. Cable requirements

To properly set up the system, it is necessary to select the appropriate cables. The table below shows the recommended cable requirements.

Function	Recommendation
Power cable	6 to 10 mm <sup>2</sup> , 3-core @ single-phase 6 to 10 mm <sup>2</sup> , 5-core @ three-phase
CAN COM cable	0.25 to 0.75 mm <sup>2</sup> , 3-core + drain

### NOTE:

- When connecting the cables to the M-Battery, you must cover the cable ends by using the proper cold-press terminal.

### d. Recommended installation space

Before installation, confirm that the installation space meets the following conditions.

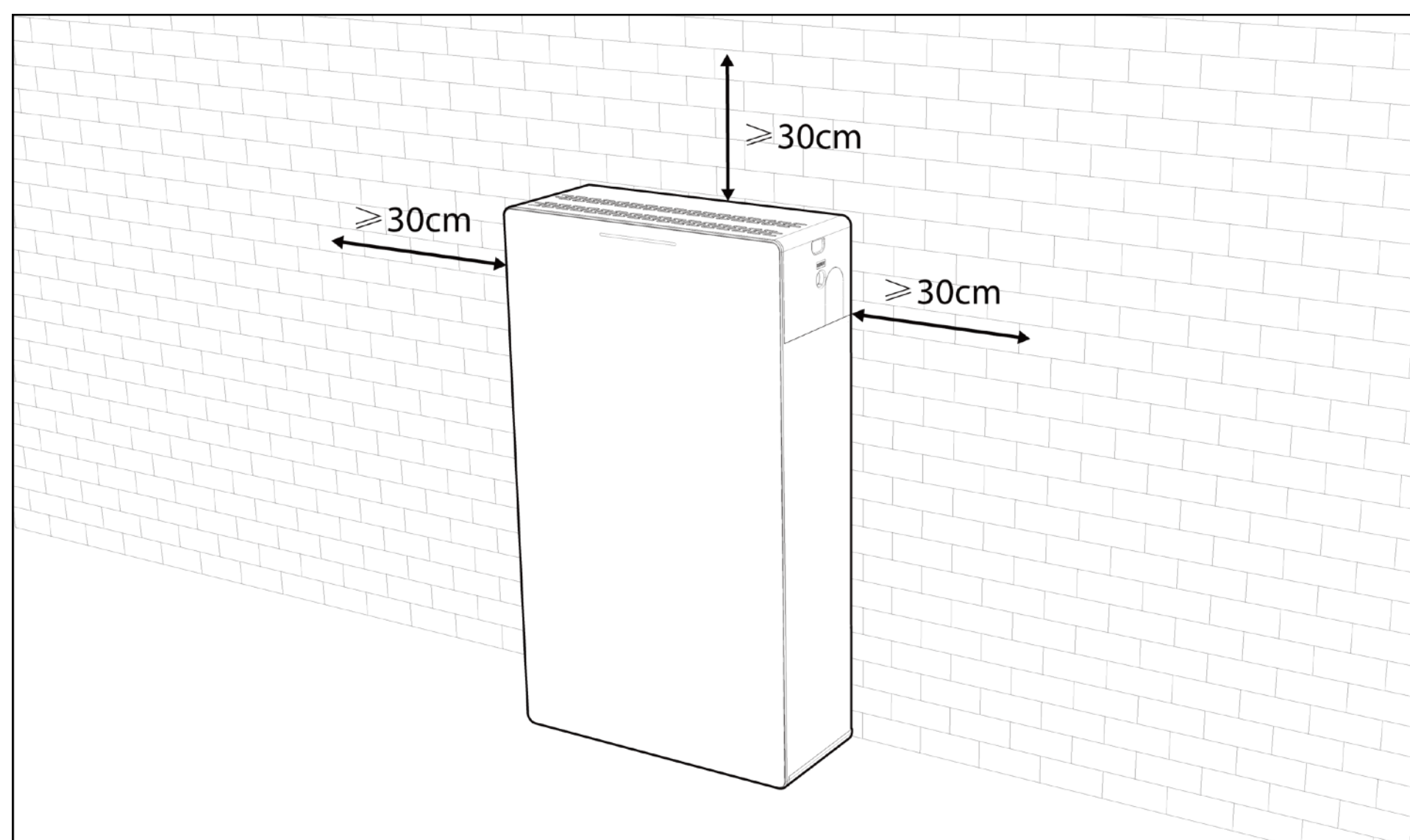

### e. Download the ATMOZEN APP

You can download the app from Google Play or Apple App Store.



Download Center



ATMOZEN APP

c. Take out the M10 expansion screws and align them with the holes. Knock them into the wall with a hammer and tighten the screws with a torque of 9–14 N·m, then loosen the screws.

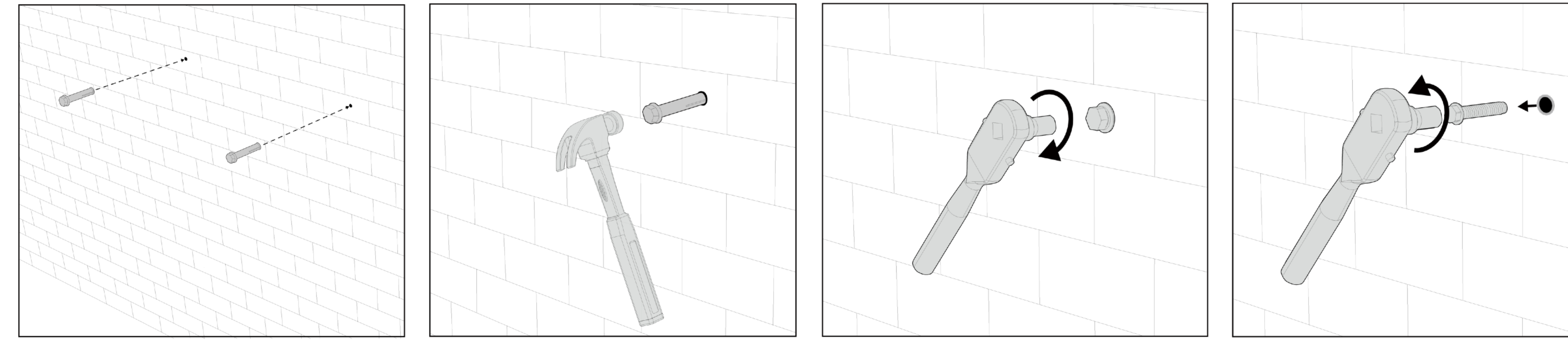

d. Place the battery close to the wall, ensuring it is parallel to the wall and perpendicular to the floor.

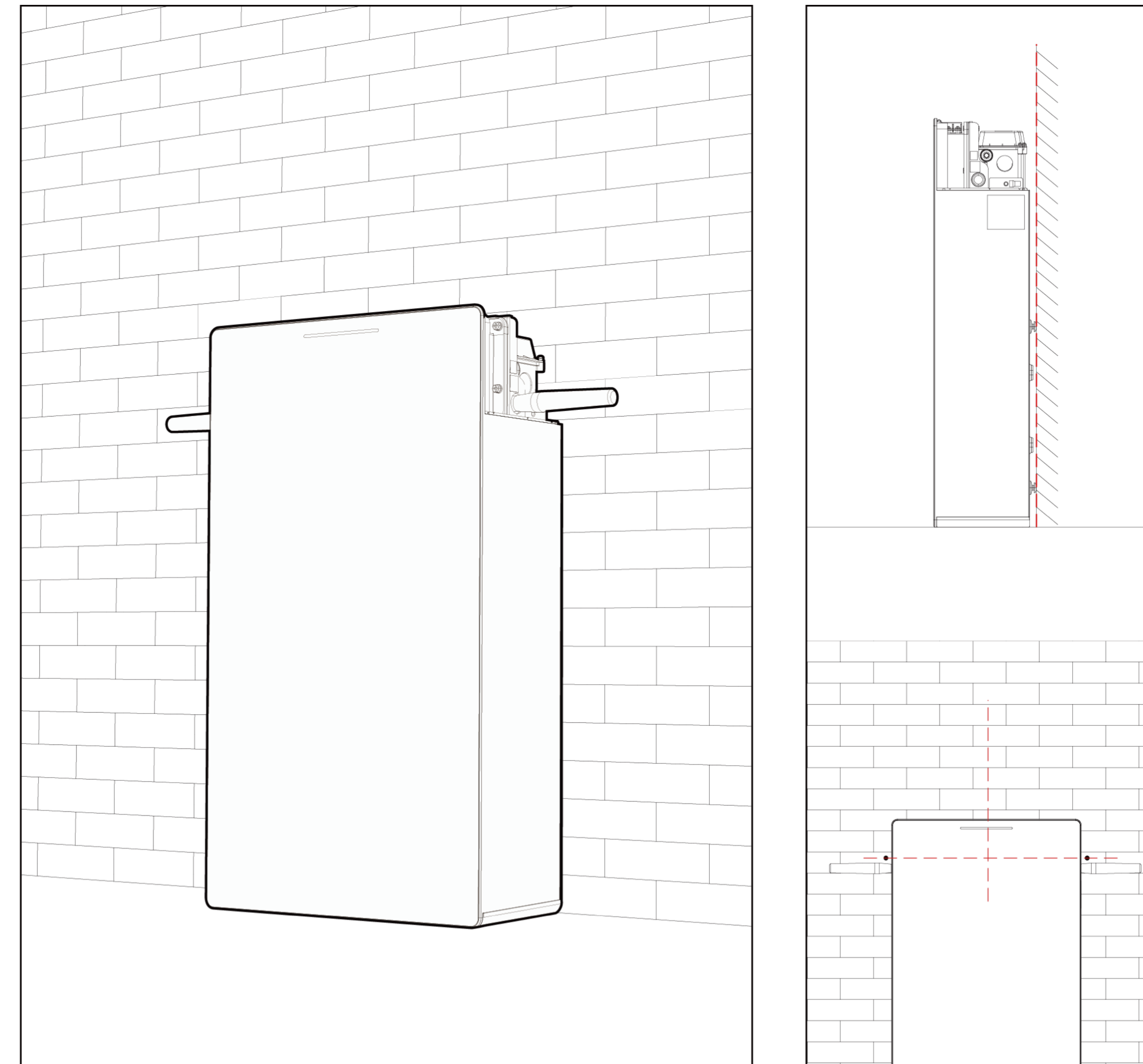

e. Remove the handlebars and take out the mounting lugs and align them with the holes on the both sides. Insert the M6 screws and tighten the screws with a torque of 3 N·m.

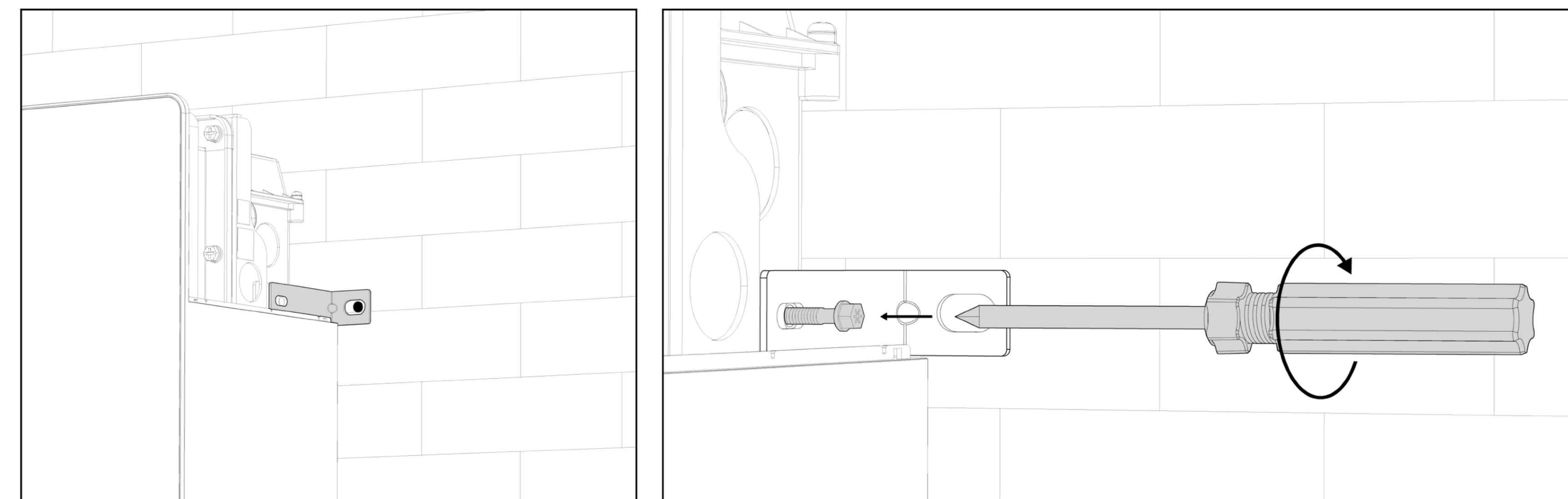

d. Take out the mounting plate and align it with the holes. Insert and tighten the screws with a torque of 9–14 N·m.

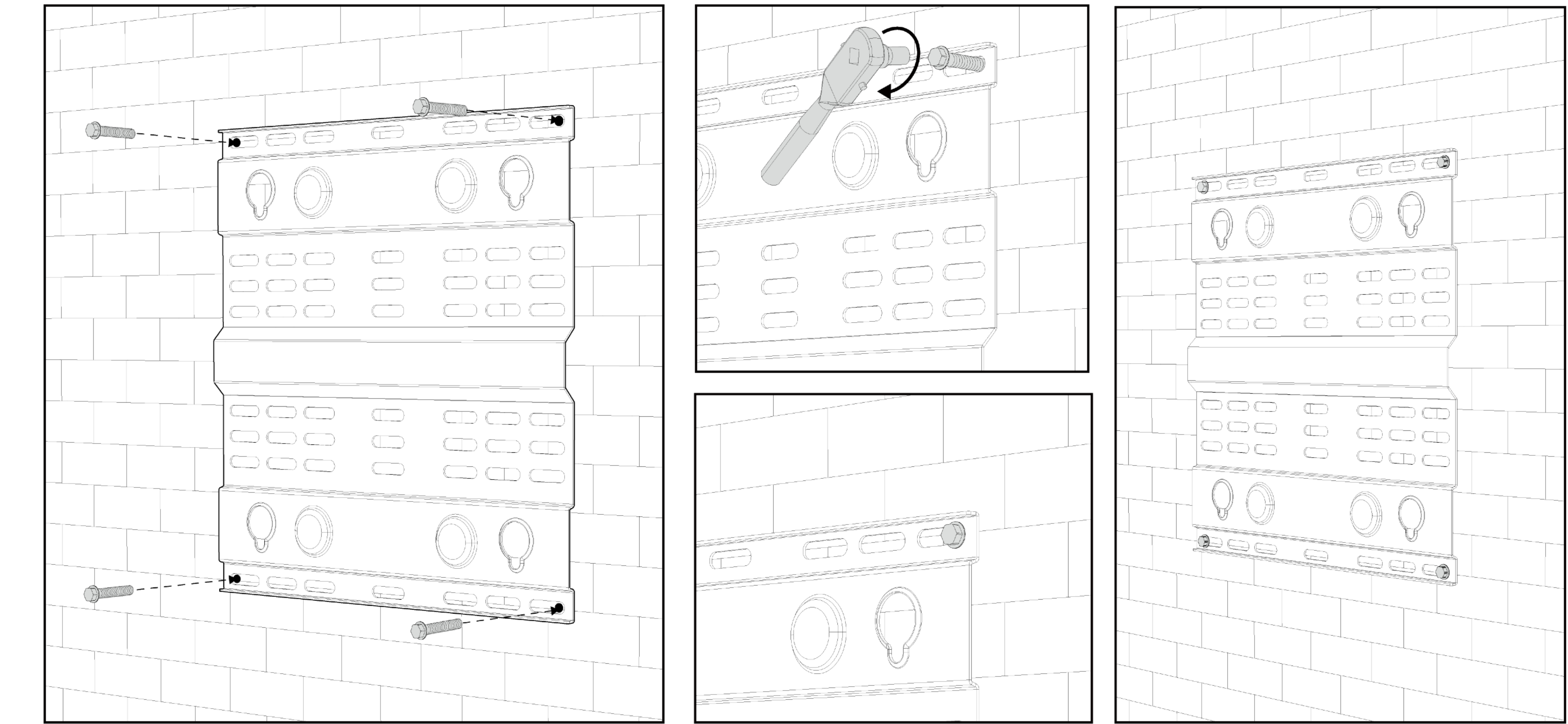

e. Insert the four mounting columns on the back of the battery into the slide rail and slide them to the end, and then remove the handlebars.

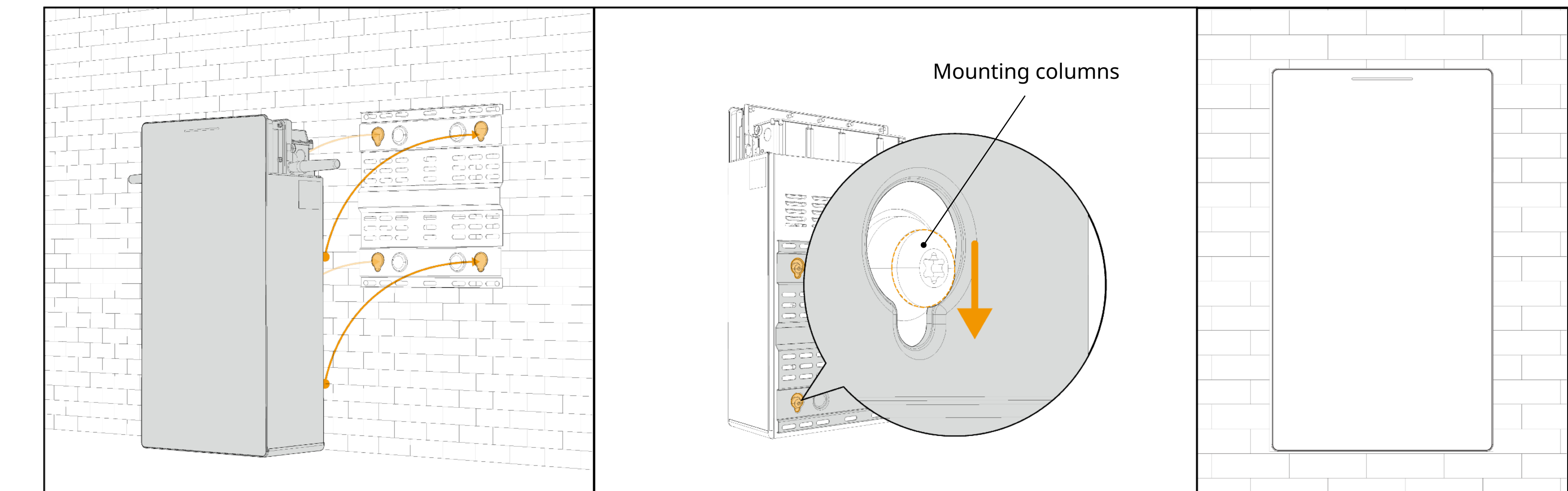

## 3. Remove the cover of the wiring cabinet

a. Loosen the 13 screws and remove the cover of the wiring cabinet.

### NOTE:

- Do not use the impact drivers and drills to tighten or loosen the screws.
- These screws are captive screws, do not attempt to unscrew them completely.

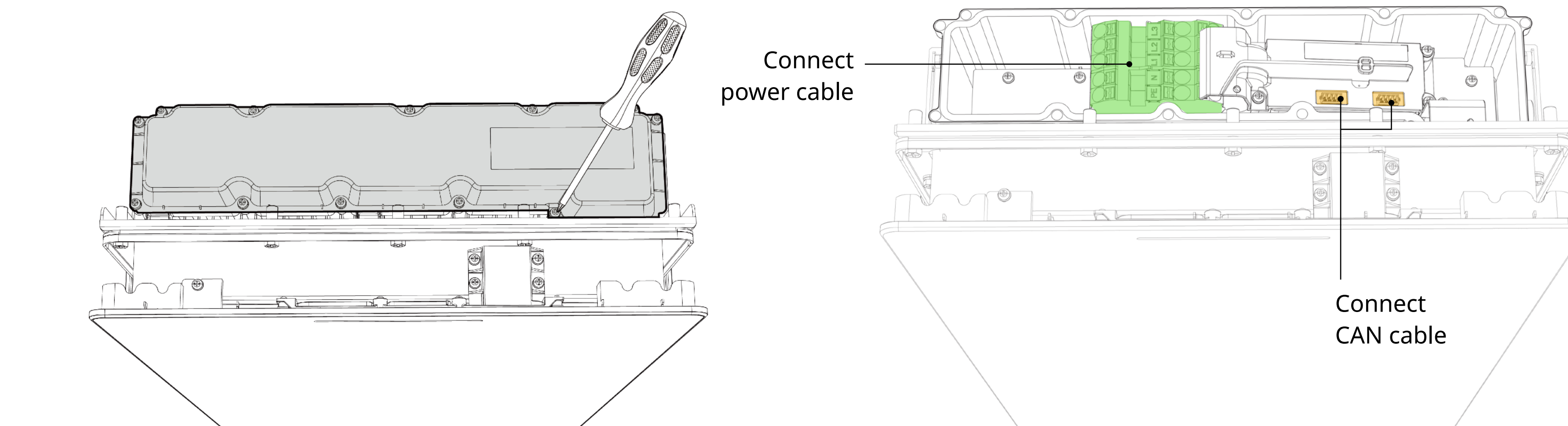



## Installation

### 1. Take out the M-ELV Battery

a. Check the accessories in the box, it contains the following items.

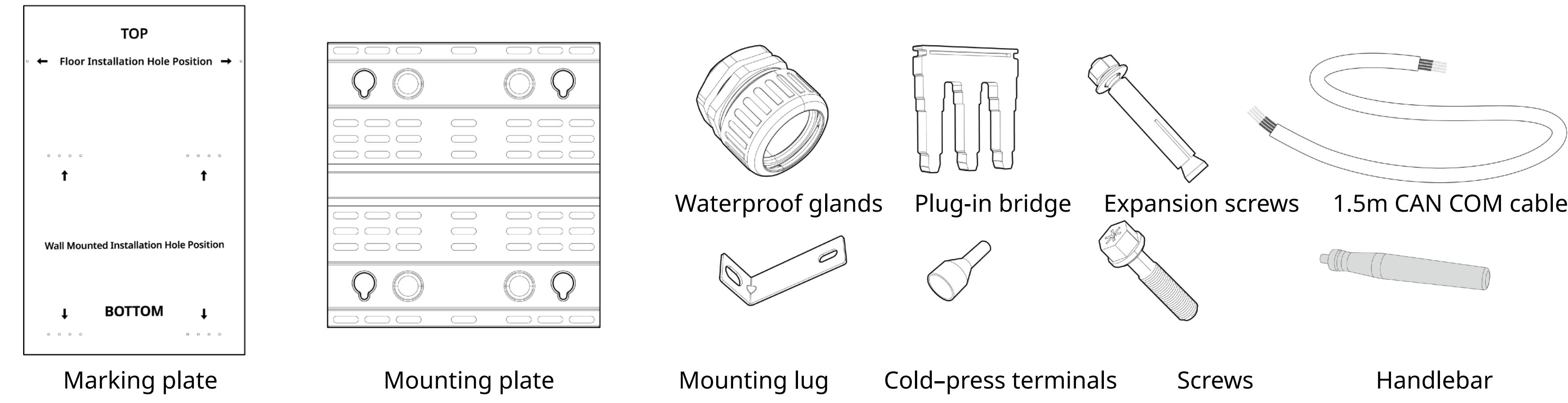

b. After unboxing, remove the upper cover of the M-ELV Battery.

c. Take out the handlebars and insert them into the holes on the both sides of the battery.

d. Remove the battery out of the box.

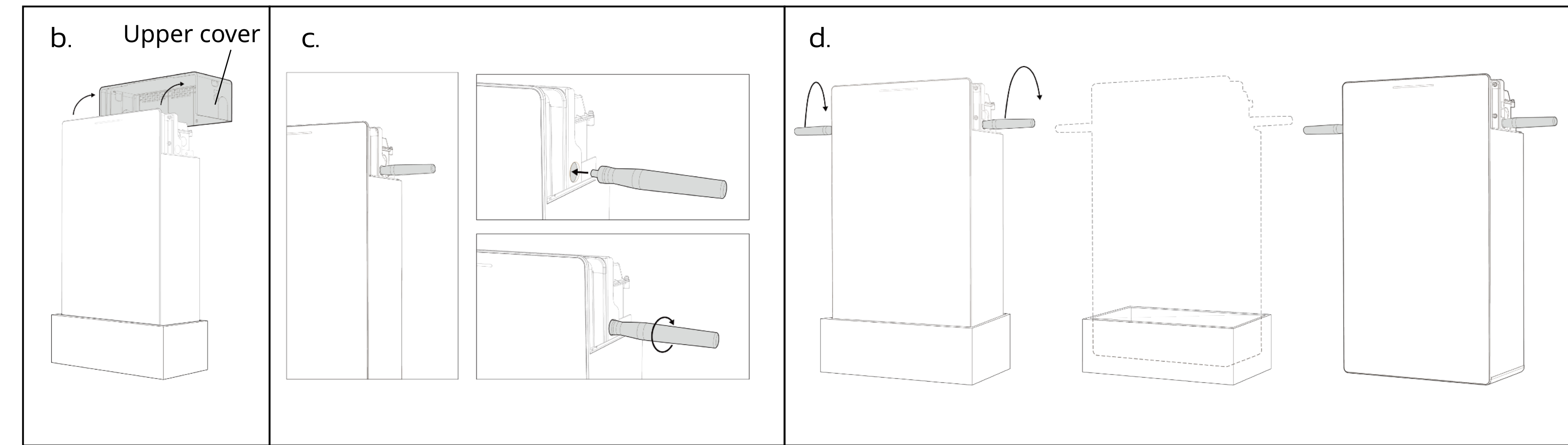

### 2. Mount the M-ELV Battery

For floor installation, the floor must be level, otherwise wall mounting is recommended.

#### 2.1 Mount on the floor

a. Take out the marking plate and place it on the wall. Use the spirit level to check that the plate is level, make the marks.

b. Drill at the two marks to a depth of 50 mm by using an electric drill with a bit (Φ14).

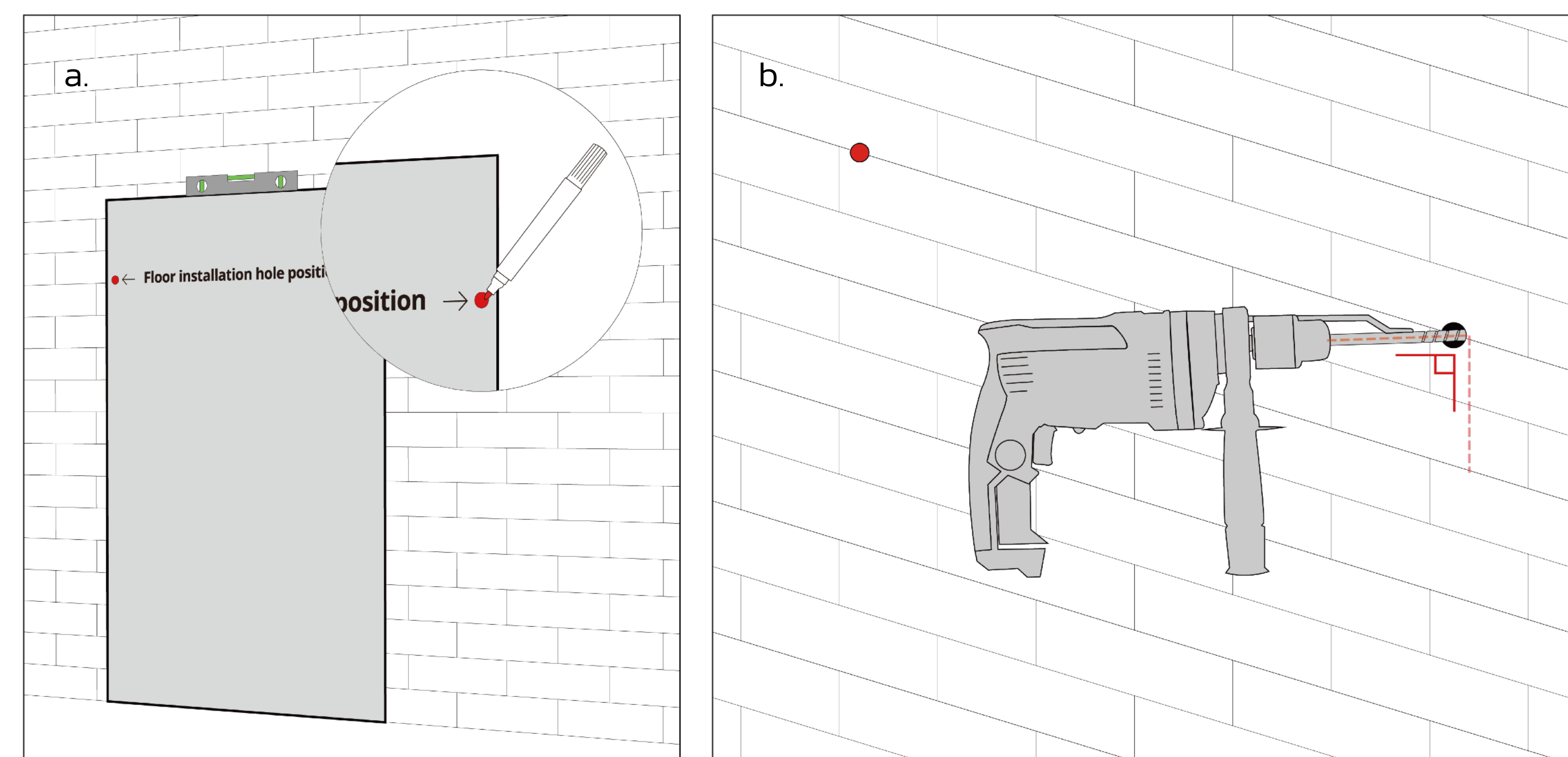

f. Insert the M10 expansion screws and tighten the screws with a torque of 9–14 N·m.

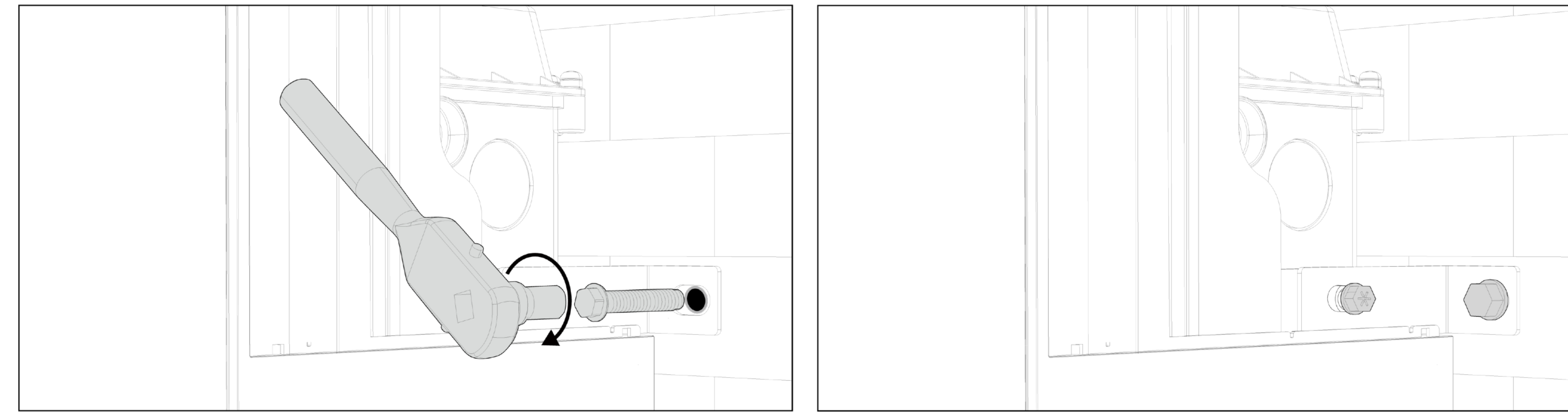

#### NOTE:

- Please do not tighten the screws completely until confirming that the mounting lugs can be fully installed.

#### 2.2 Mount on the wall

a. Take out the marking plate and place it on the wall. Use the spirit level to check that the plate is level, then make the marks.

b. Drill at the four marks to a depth of 50 mm by using an electric drill with a bit (Φ14).

#### NOTE:

- The total weight for M-ELV Battery, including the battery unit, and mounting plate, is 75 kg. The wall shall bear the battery weight.

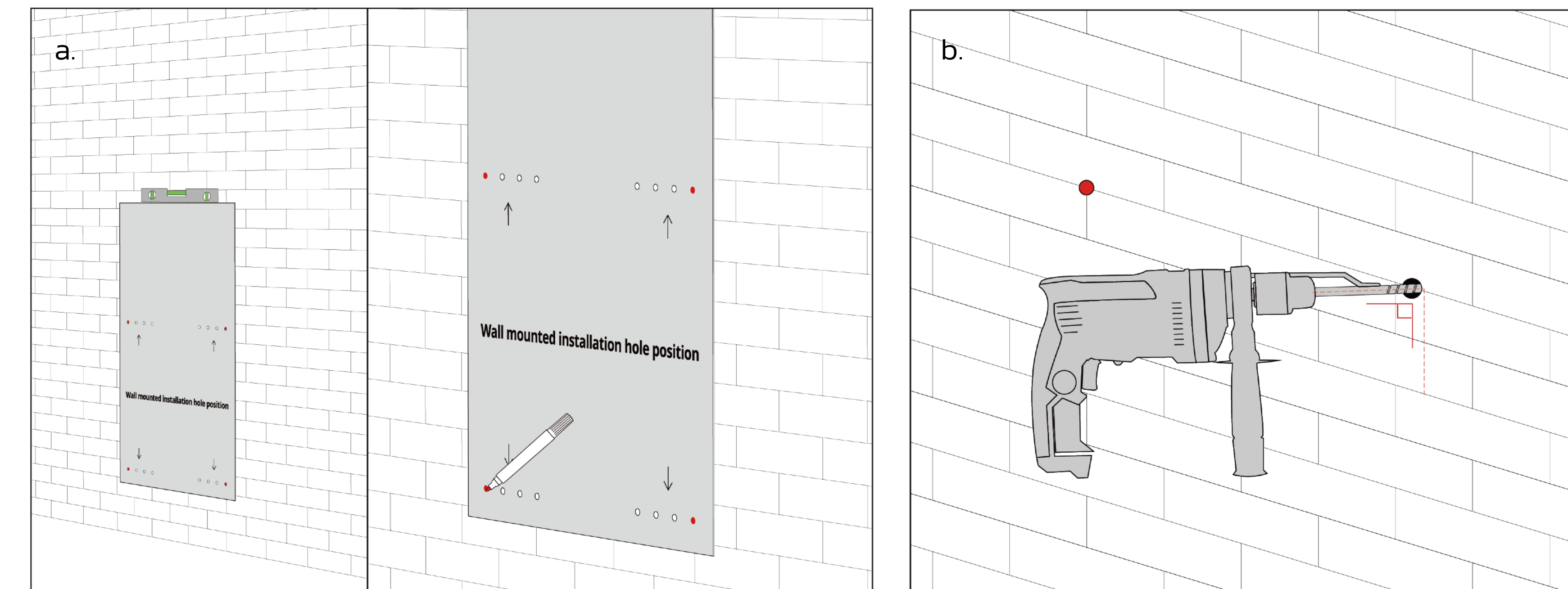

c. Take out the M10 expansion screws and align them with the holes. Knock them into the wall with a hammer and tighten the screws with a torque of 9–14 N·m, then loosen the screws.

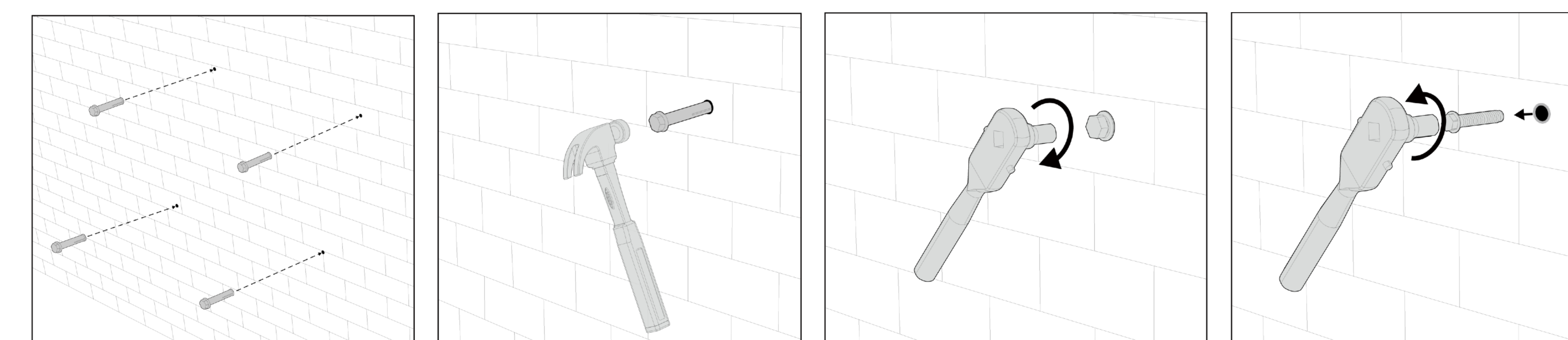

b. The details of the terminal are shown as below.

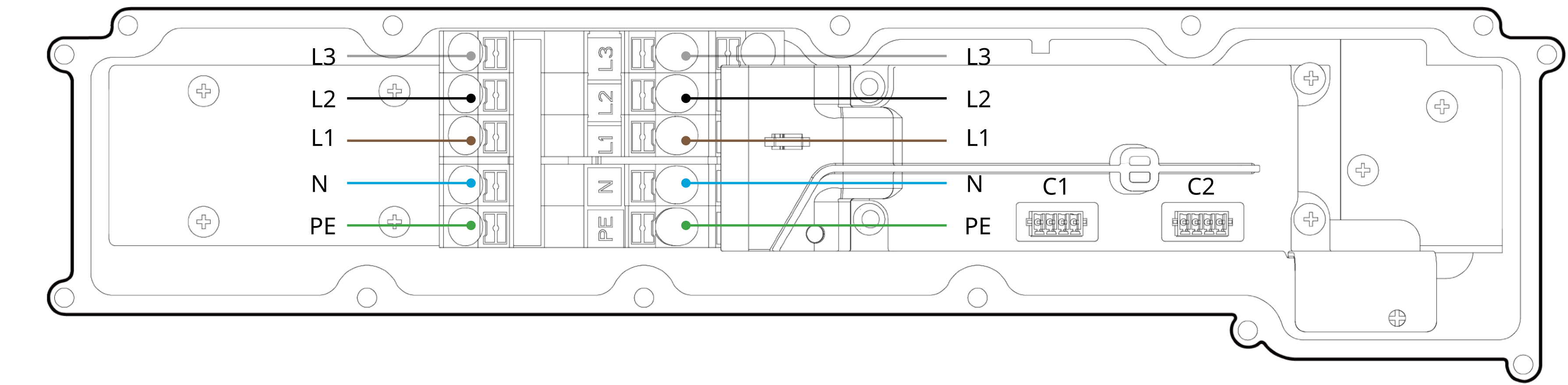

### 4. Remove the knockout

a. Use the handlebar to remove the knockout. If there are multiple batteries, please remove the knockouts according to actual needs.

b. Mount the waterproof fittings on the holes.

c. Tighten the lock nuts of the glands with a torque of 4–5 N·m and the sealing nuts with a torque of 7–7.5 N·m.

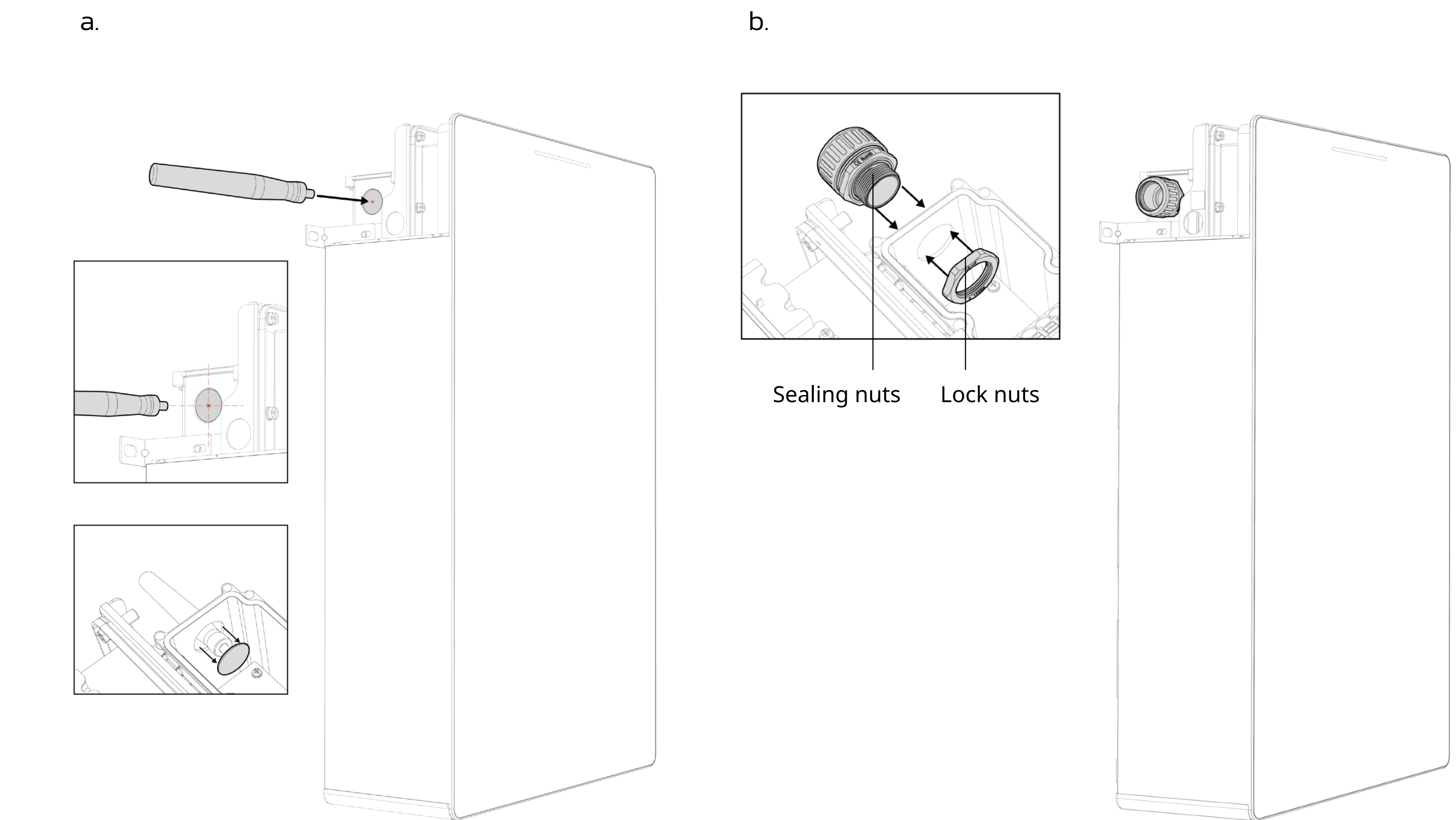

#### NOTE:

- The screwdriver should be aligned with the center of the knockout.
- Smooth the edge of the hole with a knife before tighten the nuts and wire the cables.



## 5. Wire the Cables

### 5.1 Single battery scenario

#### Section A. Wire the CAN cable

- Connect the CAN cable to the communication terminal as the label in the combiner.
- Bring in the CAN cables from the combiner through the hole of the battery.
- Remove the resistor on the C1 terminal, and connect the CAN cable to the proper terminal as the label.
- Please do not perform any operations on the C2 terminal and resistor.
- Arrange the cables and check the wiring is correct.

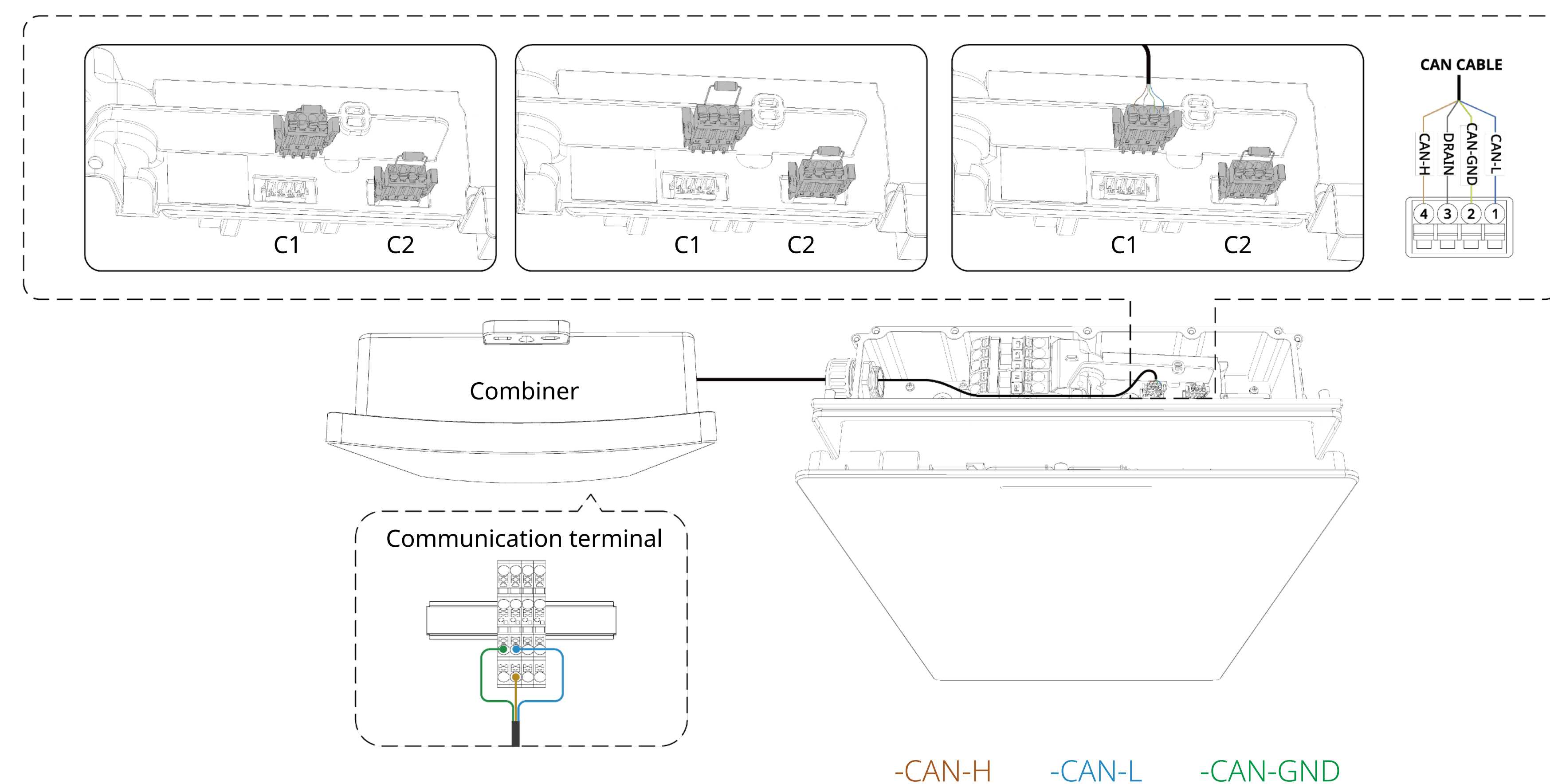

#### NOTE:

- If the 1.5m CAN cable is used to connect the combiner and the battery, the drain terminal to the combiner need be cut off.

### 5.2 Multiple batteries scenario

#### Section A. Wire the CAN cable

- Connect the CAN cable to the communication terminal as the label in the combiner.
- Bring in the CAN cable from the combiner and 1.5 m CAN cable through the hole of the battery.
- For the battery 1, remove the resistor on the C1 and C2 terminal, and then connect the cable to the C1 and C2 terminal as below.

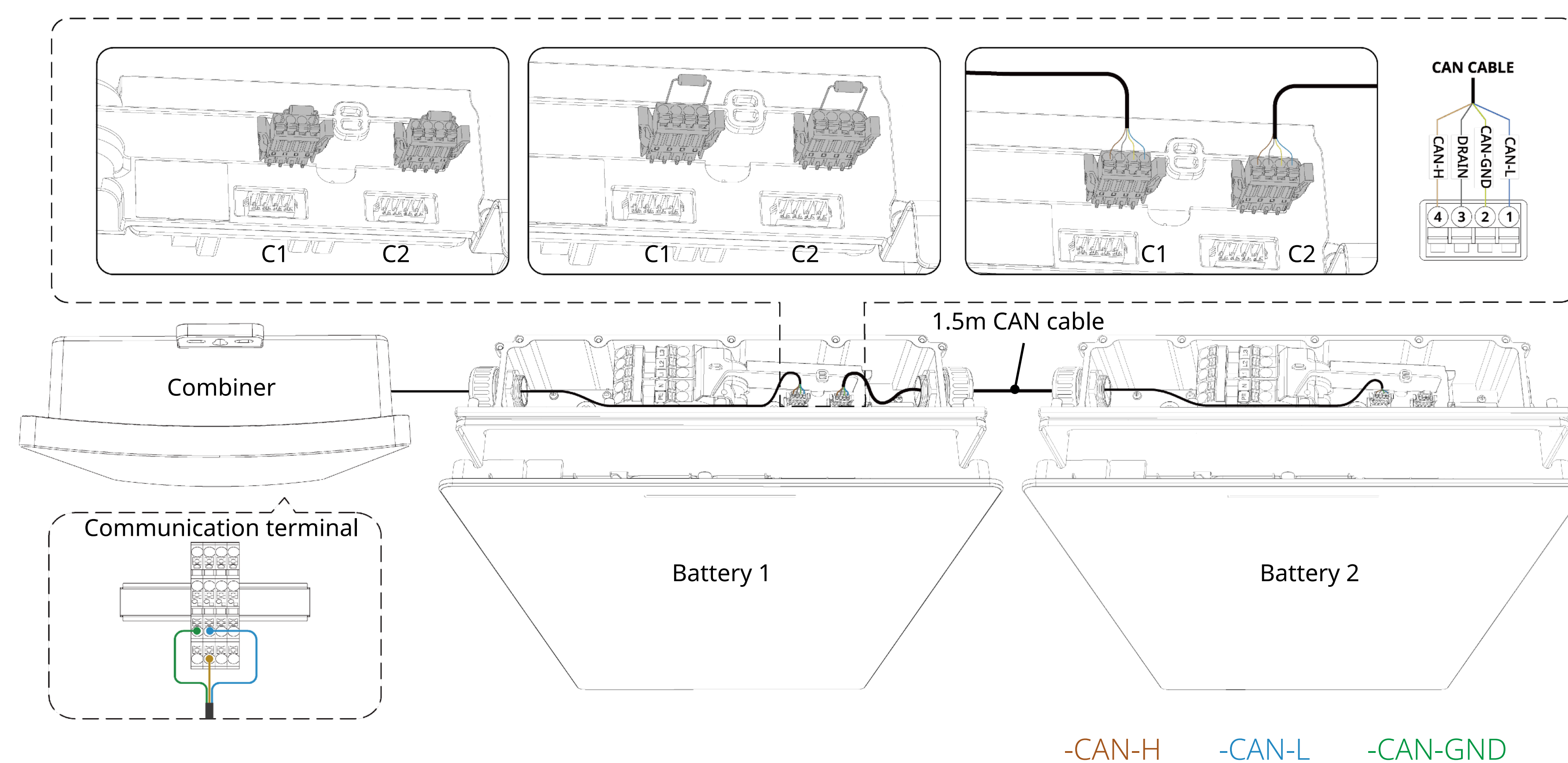

#### NOTE:

- If the 1.5m CAN cable is used to connect the combiner and the battery, the drain terminal to the combiner need be cut off.

- For the battery 2, remove the resistor on the C1 terminal, and then connect the cable to the C1 terminal as below. Please do not perform any operations on the C2 terminal and resistor.
- Arrange the cables and check the wiring is correct.

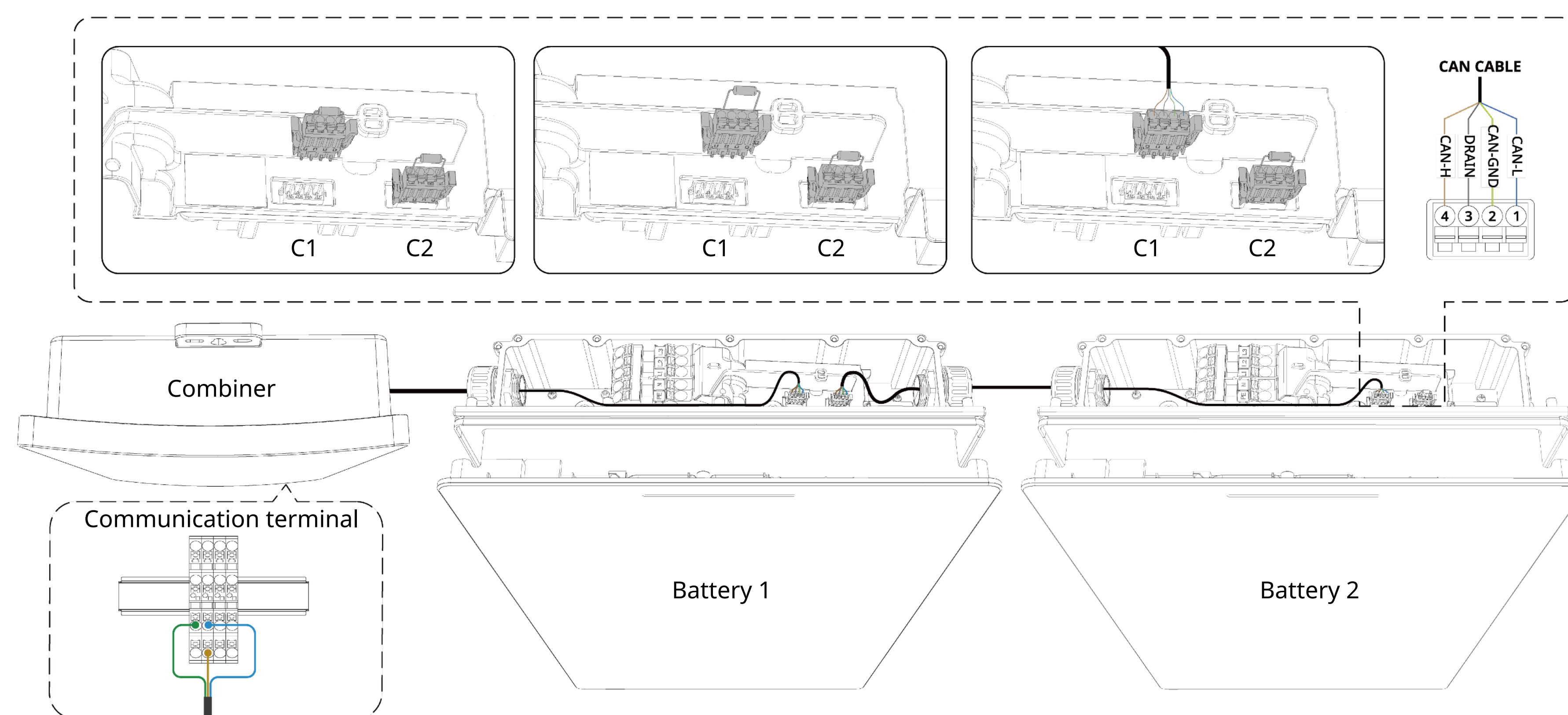

### 6. Close the cover of the wiring cabinet

- Re-install the cover. Follow the sequence (from 1 to 13) as shown in the figure to tighten the 13 screws.

#### NOTE:

- Do not use the impact drivers and drills to tighten or loosen the screws.

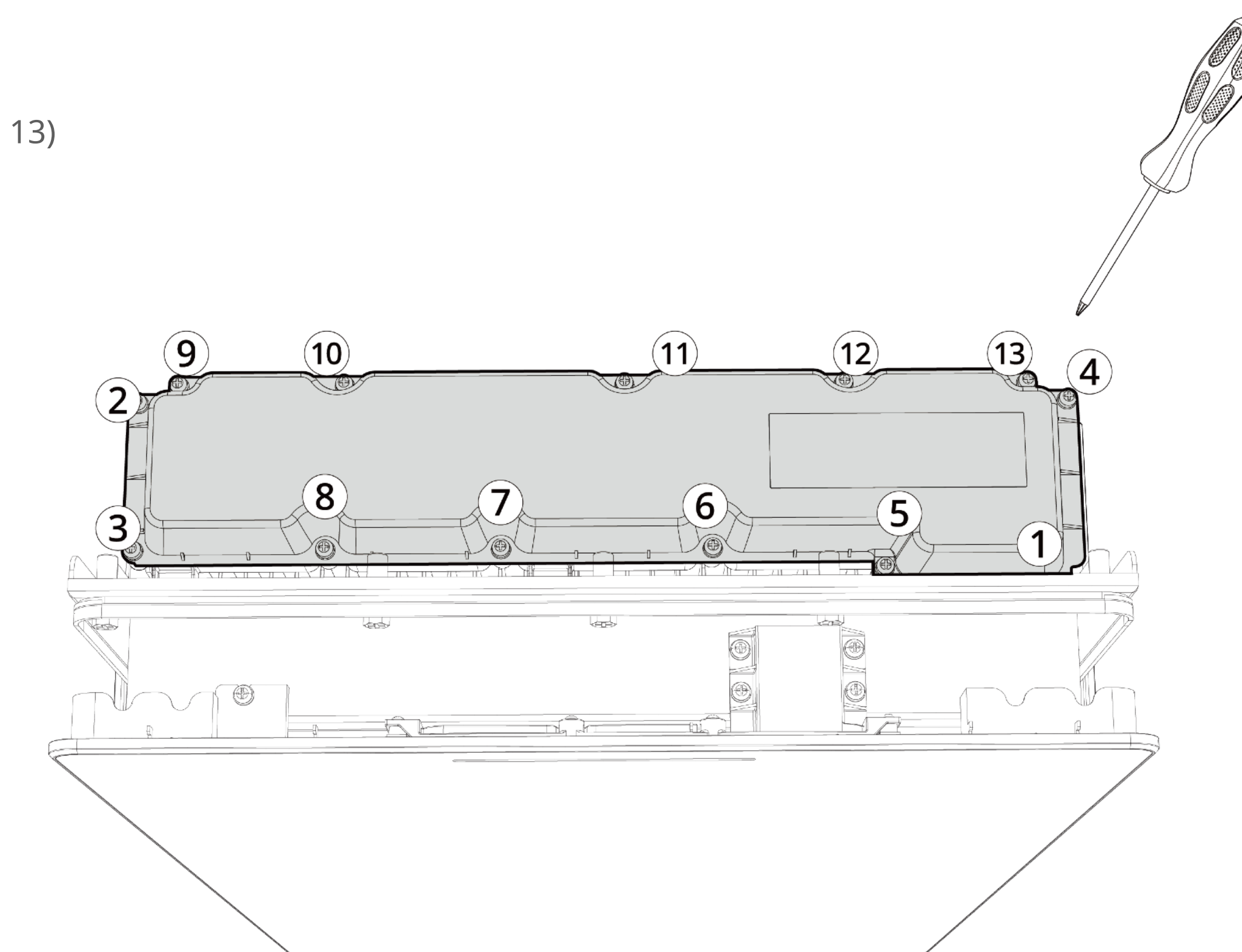

### 7. Remove the knockout of the upper cover

- Wear the protective gloves and remove the knockout of the upper cover.

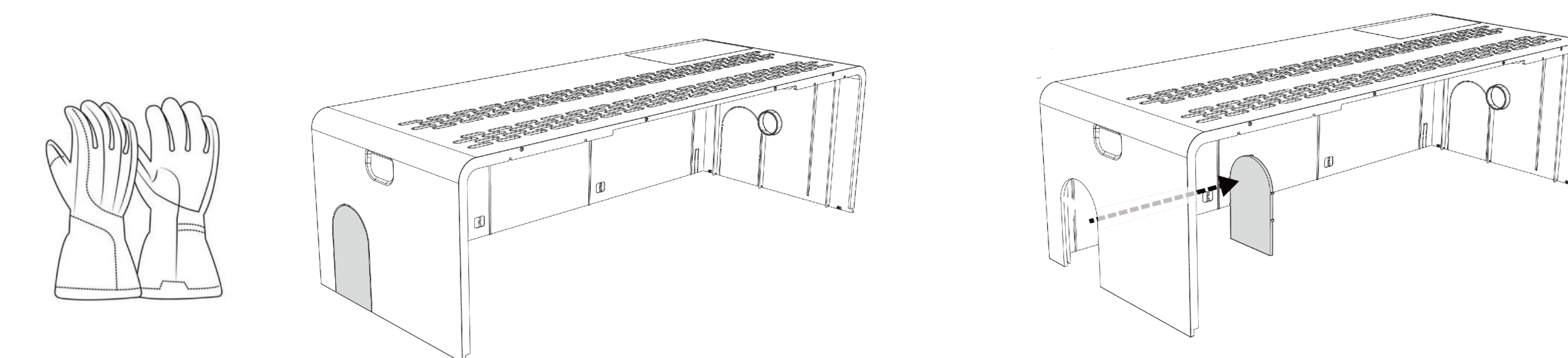

#### NOTE:

- Please remove the knockout according to the wiring conditions.

### 8. Close the upper cover

- Close the upper cover.

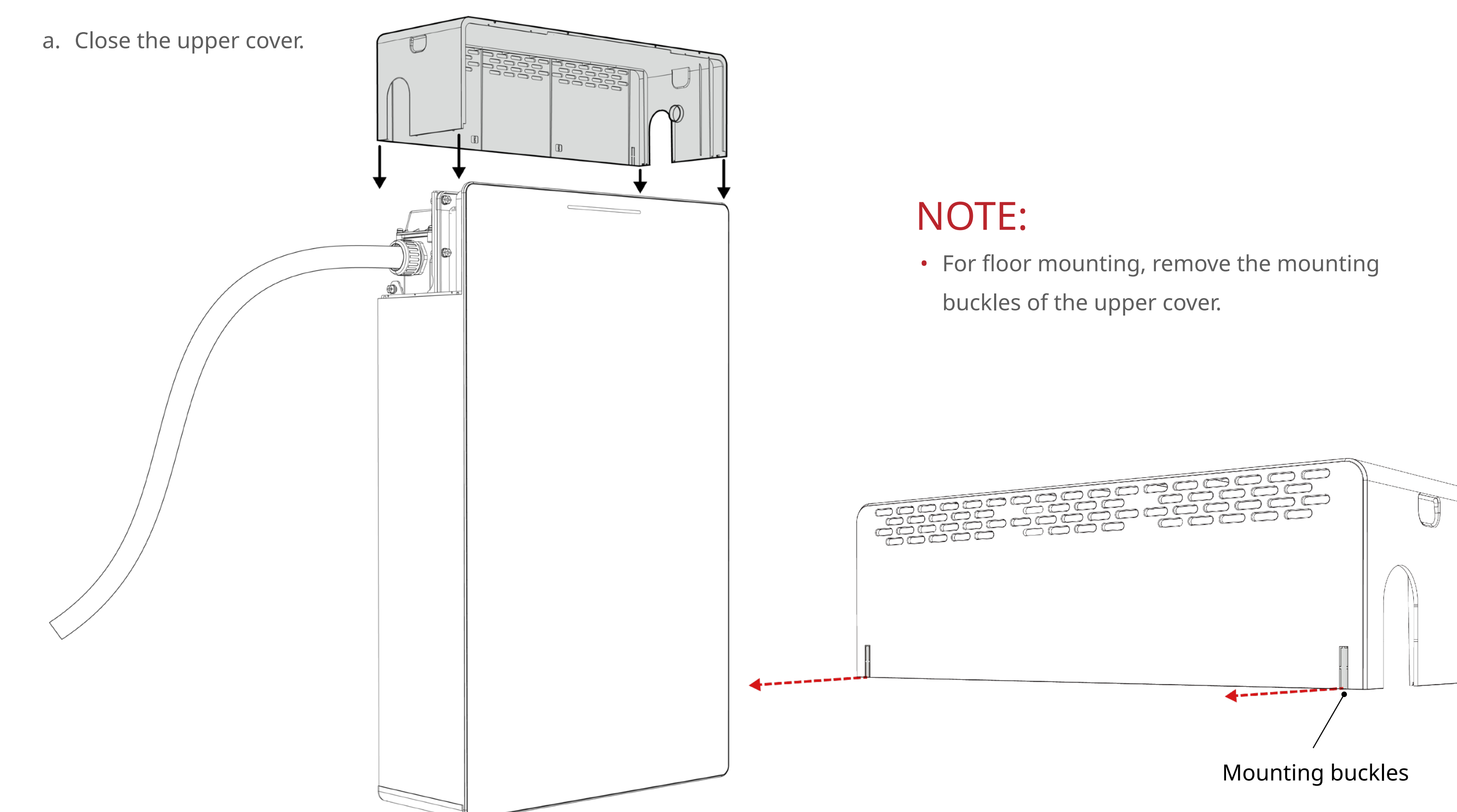

#### NOTE:

- For floor mounting, remove the mounting buckles of the upper cover.



## Section B. Wire the CAN communication cable

### NOTE:

- The cables must connect to the battery breaker and PE terminal in the combiner. Please check the label inside the combiner for more information. Incorrect connection of L and N will damage the equipment.
- When stripping the cable, remove approximately 120 mm of the insulation layer from the power cable.

- Connect the cables to the battery breaker and PE terminal block in the combiner.
- Bring in the power cables from the combiner through the hole of the battery.
- Connect the cables to the power and PE terminal block in the battery.

### Single-phase application

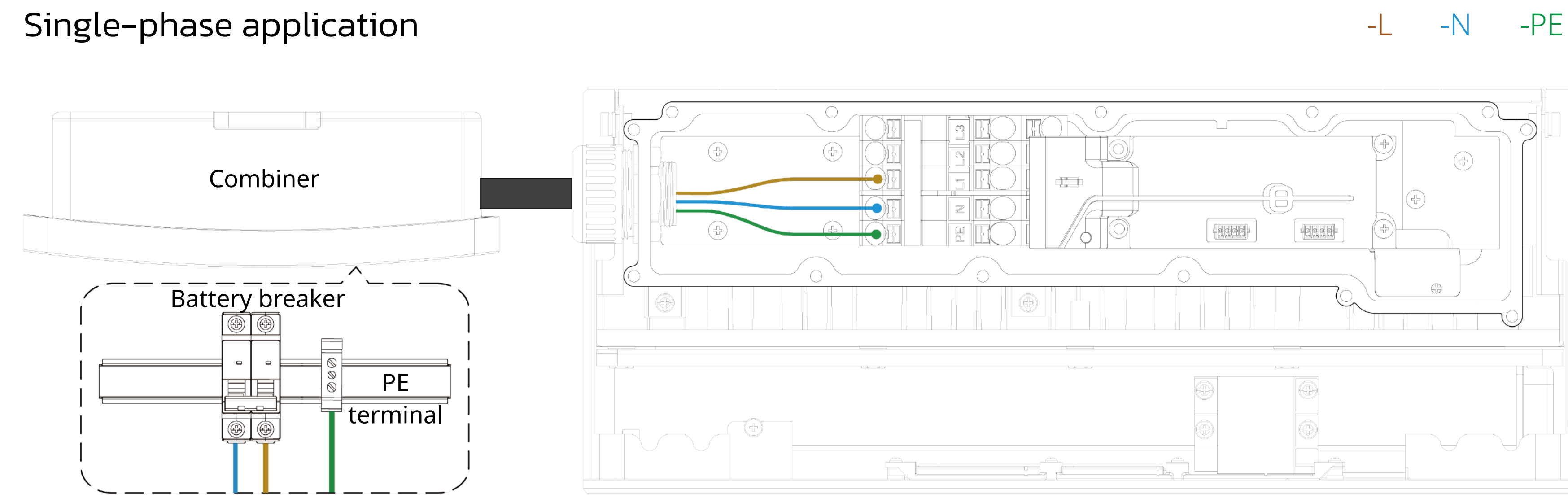

### NOTE:

- For single-phase systems, the plug-in bridge must be fully inserted as shown.
- After the installation, confirm that the plug-in bridge is not loose.

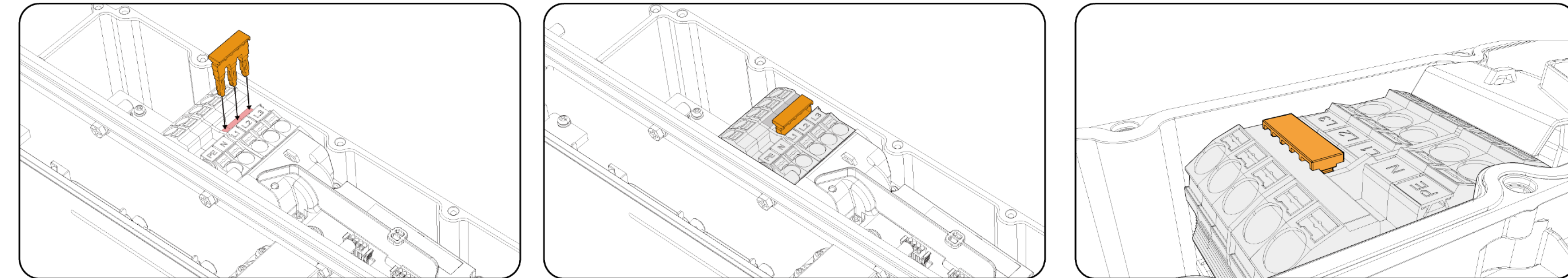

### Three-phase application

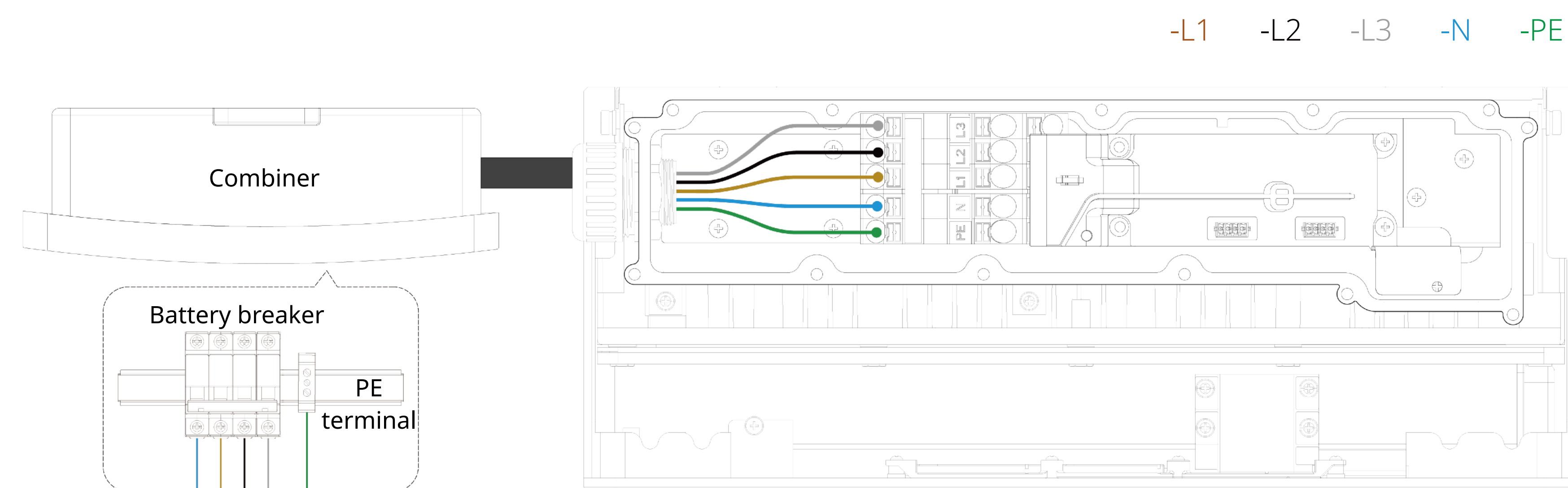

## Section B. Wire the power cable

### NOTE:

- The cables must connect to the battery breaker and PE terminal in the combiner. Please check the label inside the combiner for more information. Incorrect connection of L and N will damage the equipment.
- When stripping the cables, remove approximately 120 mm of the cable's insulation layer on the left side of the battery and 270 mm of the cable's insulation layer on the right side.

- Connect the cables to the battery breaker and PE terminal in the combiner.
- Bring in the power cables from the combiner through the hole of the battery.
- Connect the cables to the power and PE terminal block in the battery.

### Single-phase application

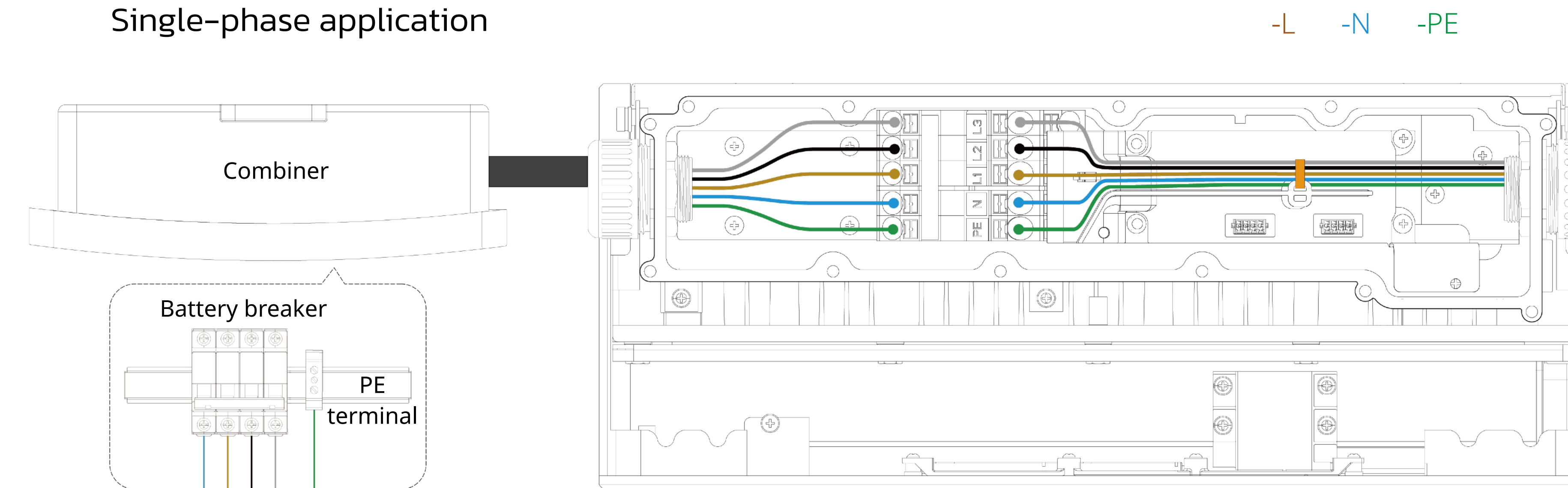

### NOTE:

- For single-phase systems, the plug-in bridge must be fully inserted as shown.
- After the installation, confirm that the plug-in bridge is not loose.

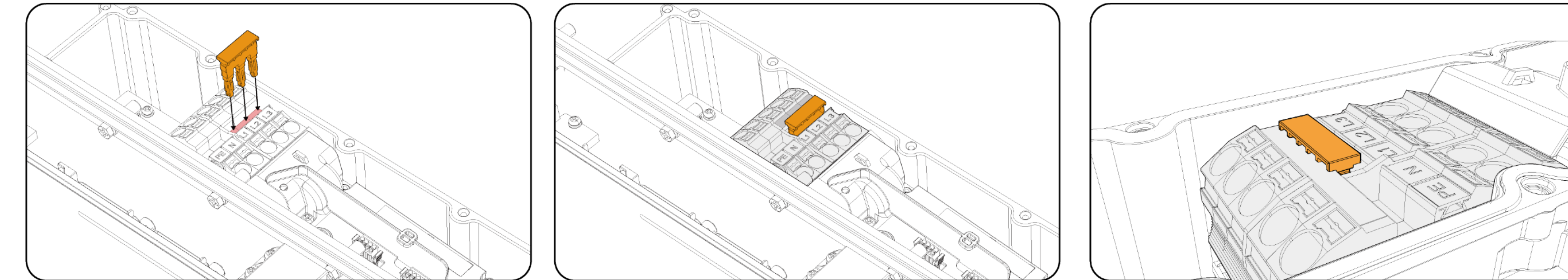

### Three-phase application

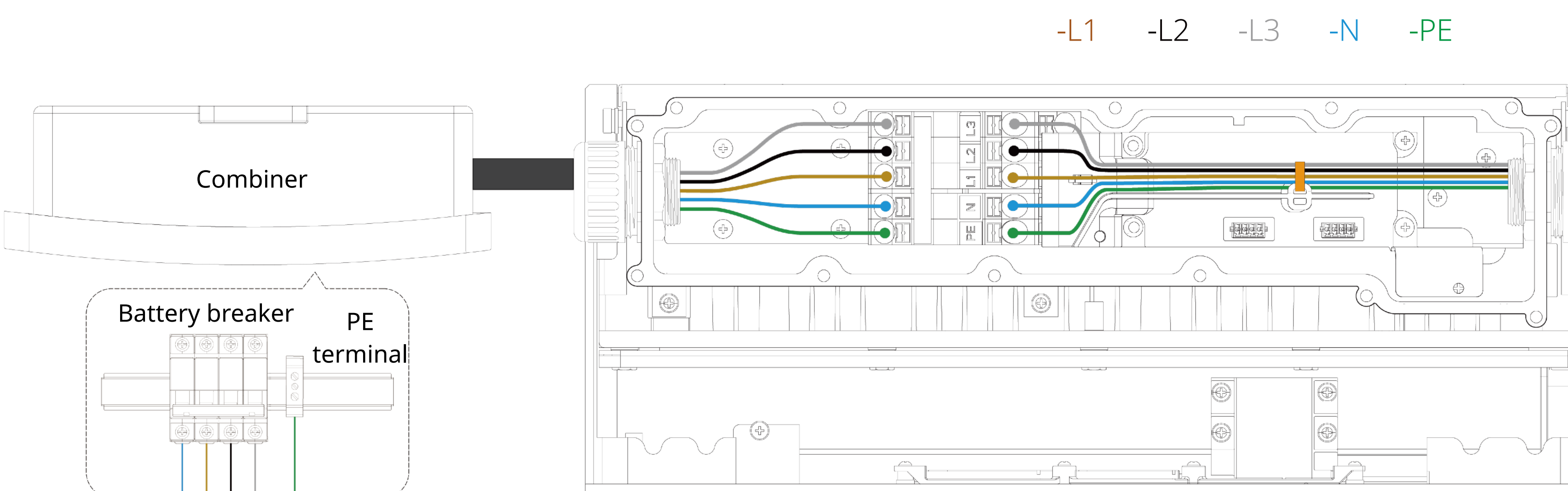

## 9. Power on the system

- Use the multimeter to measure the voltage between the N pole and L1 pole ( or L2 pole, L3 pole). The voltage value should be approximately the nominal phase voltage, e.g. 220 V, 230 V and 240 V.
- Switch on the battery breaker in the combiner and power on the system.

## 10. Activate the system

- Log in to the ATMOZEN APP on your mobile phone and follow the deployment guide in the app to activate the system.
- After the system is activated, the SOC status LED will be solid blue.

## LED Indicator Description

The M-ELV Battery has two types of LEDs and the following table describes their status.

Function	Colour	Description
SOC status	Solid blue	Remaining battery energy percentage
Battery status	Quick flash	Abnormal working condition
	Solid red	The battery has an internal fault
	Dim	Normal operation

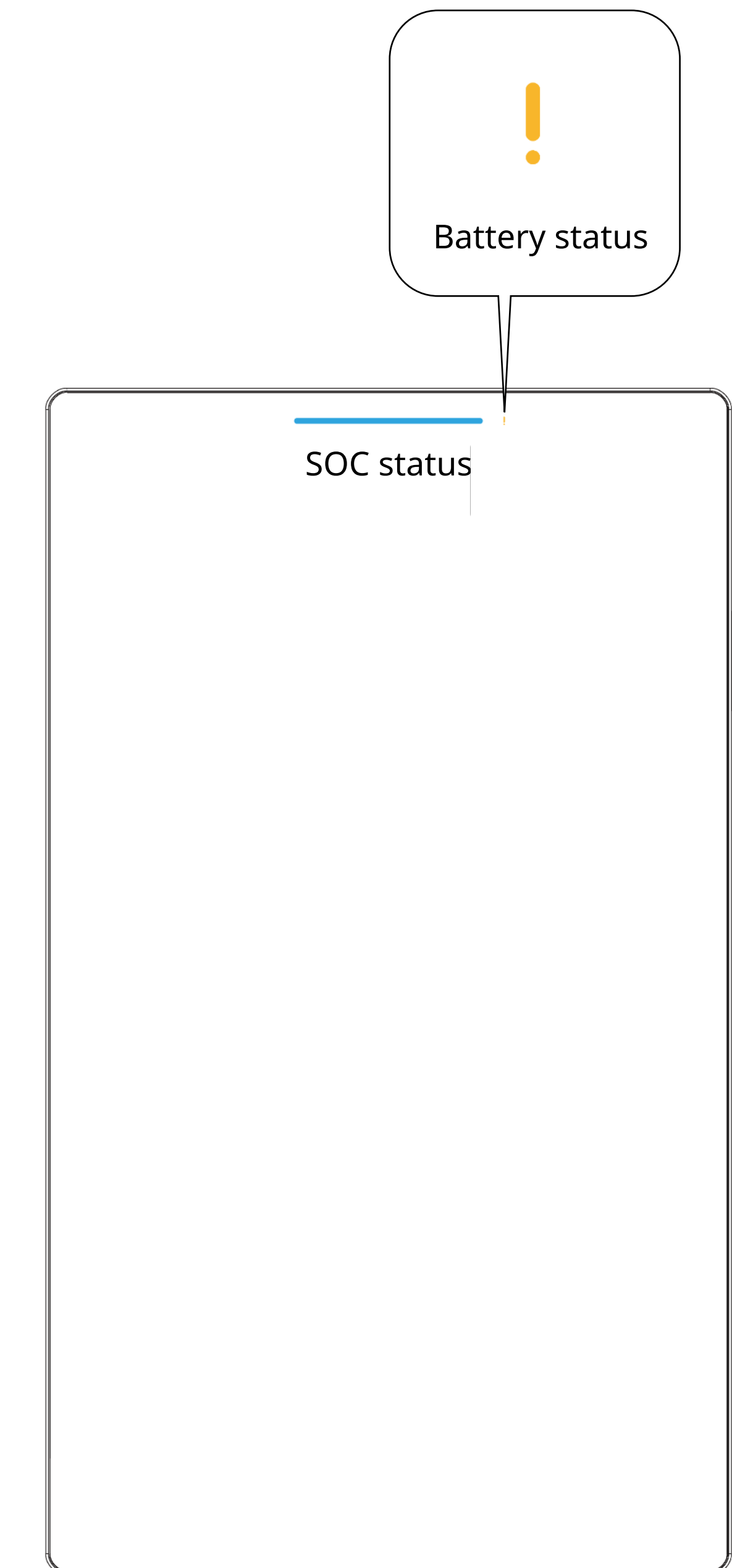



# ATMOCE

## 印刷要求

纸张尺寸	444*210mm。文件内容等比例缩放	
纸张类型	80g双胶纸	
印刷要求	全彩印刷，正反印刷	
成品样式	三折页，成品长宽：148*210mm 首页朝上，P7不印刷	
字体要求	一级标题	<b>Noto Sans Bold</b>
	正文	Noto Sans Regular
检查要求	印刷质量	颜色准确性，确保颜色色彩准确
		图像分辨率，确保图像清晰，细节部分不模糊
		是否存在漏印、重印、渗印、断点、虚线等质量问题。
	印刷位置和尺寸	检查文字、图形等内容的位置、大小、间距等是否一致，以及是否存在偏移、倾斜、错位、变形等问题。
纸张质量	确保纸张克重满足要求，折页不易裂开	
	检测纸张上的缺陷，如毛边、切口、裂口、破损等问题	

## 版本说明

版本号	版本说明	发布日期
Rev 1.0.3	一维码改明码，电池名称改为M-ELV Battery	23/06/2025
Rev 1.0.2	修订接线仓结构件，调整接线步骤	06/05/2025
Rev 1.0.1	修订挂墙安装及落地安装方式，修订电力线及通信线描述	03/12/2025
Rev 1.0.0	首次发布	03/03/2025