

User Manual

PV Grid-Connected Inverter

SG125CX-P2 / SG110CX-P2 / SG75CX-P2



All Rights Reserved

All Rights Reserved

No part of this document can be reproduced in any form or by any means without the prior written permission of Sungrow Power Supply Co., Ltd (hereinafter "SUNGROW").

Trademarks

SUNGROW and other Sungrow trademarks used in this manual are owned by SUNGROW.

All other trademarks or registered trademarks mentioned in this manual are owned by their respective owners.

Software Licenses

- It is prohibited to use data contained in firmware or software developed by SUNGROW, in part or in full, for commercial purposes by any means.
- It is prohibited to perform reverse engineering, cracking, or any other operations that compromise the original program design of the software developed by SUNGROW.

About This Manual

The manual mainly contains the product information, as well as guidelines for installation, operation, and maintenance. The manual does not include complete information about the photovoltaic (PV) system. Readers can get additional information at www.sungrowpower.com or on the webpage of the respective component manufacturer.

Target Group

This manual is intended for professional technicians who are responsible for installation, operation, and maintenance of inverters, and users who need to check inverter parameters. The inverter must only be installed by professional technicians. The professional technician is required to meet the following requirements:

- Know electronic, electrical wiring and mechanical expertise, and be familiar with electrical and mechanical schematics.
- Have received professional training related to the installation and commissioning of electrical equipment.
- Be able to quickly respond to hazards or emergencies that occur during installation and commissioning.
- Be familiar with local standards and relevant safety regulations of electrical systems.
- Read this manual thoroughly and understand the safety instructions related to operations.

How to Use This Manual

Please read this manual carefully before using the product and keep it properly at a place for easy access.

All contents, pictures, marks, and symbols in this manual are owned by SUNGROW. No part of this document may be reprinted by the non-internal staff of SUNGROW without written authorization.

Contents of this manual may be periodically updated or revised, and the actual product purchased shall prevail. Users can obtain the latest manual from support.sungrowpower.com or sales channels.

Security Declaration

For details on the product's network security vulnerability response process and vulnerability disclosure, please visit the following website: <https://en.sungrowpower.com/security-vulnerability-management>.

For more information on network security, please refer to the user manual of the communication module or the Data Logger that comes with the product.

Symbols

This manual contains important safety instructions, which are highlighted with the following symbols, to ensure personal and property safety during usage, or to help optimize the product performance in an efficient way.

Please carefully understand the meaning of these warning symbols to better use the manual.

DANGER

Indicates high-risk potential hazards that, if not avoided, may lead to death or serious injury.

WARNING

Indicates moderate-risk potential hazards that, if not avoided, may lead to death or serious injury.

CAUTION

Indicates low-risk potential hazards that, if not avoided, may lead to minor or moderate injury.

NOTICE

Indicates potential risks that, if not avoided, may lead to device malfunctions or financial losses.



“NOTE” indicates additional information, emphasized contents or tips that may be helpful, e.g., to help you solve problems or save time.

Contents

All Rights Reserved.....	I
About This Manual.....	II
1 Safety Instructions.....	1
1.1 Unpacking and Inspection.....	2
1.2 Installation Safety.....	3
1.3 Electrical Connection Safety.....	3
1.4 Operation Safety.....	6
1.5 Maintenance Safety.....	6
1.6 Disposal Safety.....	8
2 Product Description.....	9
2.1 System Introduction.....	9
2.2 Product Introduction.....	11
2.3 Symbols on Product.....	12
2.4 LED Indicator.....	13
2.5 Circuit Diagram.....	14
2.6 Function Description.....	15
3 Unpacking and Storage.....	19
3.1 Unpacking and Inspection.....	19
3.2 Inverter Storage.....	19
4 Mechanical Mounting.....	21
4.1 Safety During Mounting.....	21
4.2 Location Requirements.....	22
4.2.1 Installation Environment Requirements.....	23
4.2.2 Carrier Requirements.....	25
4.2.3 Angle Requirements.....	25
4.2.4 Clearance Requirements.....	27
4.3 Installation Tools.....	28
4.4 Moving Inverter.....	29

4.5	Installing Mounting-bracket.....	30
4.5.1	PV Bracket-Mounted Installation.....	31
4.5.2	Wall-Mounted Installation.....	33
4.5.3	Pole-Mounting.....	35
4.6	Installing Inverter.....	37
4.7	Installing Optimizer(Optional).....	38
5	Electrical Connection.....	40
5.1	Safety Instructions.....	40
5.2	Terminal Description.....	42
5.3	Electrical Connection Overview.....	44
5.4	Crimp OT/DT terminal.....	47
5.5	External Protective Grounding Connection.....	48
5.5.1	External Protective Grounding Requirements.....	49
5.5.2	Connection Procedure.....	49
5.6	AC Cable Connection.....	50
5.6.1	AC Side Requirements.....	50
5.6.2	Requirements for OT/DT Terminal.....	52
5.6.3	Connection Procedure (For a Multi-core Cable).....	53
5.6.4	Connection Procedure (For Single-core Cables).....	58
5.7	DC Cable Connection.....	62
5.7.1	PV Input Configuration.....	64
5.7.2	Assembling PV Connectors.....	66
5.7.3	Installing PV Connector.....	68
5.8	Wiring of Tracking System Power Cable (optional).....	72
5.9	Wireless Communication Module Connection(optional).....	74
5.10	WiNet-S Connection (optional).....	75
5.10.1	Ethernet Communication.....	75
5.10.2	WLAN Communication.....	77
5.11	EyeS2 Connection (optional).....	78
5.11.1	WLAN Communication.....	78
5.12	Communication Junction Box.....	79
5.13	Communication Wiring Board.....	79
5.14	RS485 Connection.....	80
5.14.1	Interface Description.....	80

5.14.2 RS485 Communication System.....	82
5.14.3 Connection Procedure(Terminal Block).....	83
5.14.4 Connection Procedure (RJ45 Interface).....	85
5.15 Dry Contact Connection.....	87
5.15.1 Dry Contact Function.....	87
5.15.2 Wiring Procedure.....	89
5.16 DRM Connection.....	90
5.16.1 DRM Function.....	90
5.16.2 Connection Procedure.....	91
6 Commissioning.....	94
6.1 Inspection Before Commissioning.....	94
6.2 Commissioning Procedure.....	94
6.3 Optimizer Physical Layout (Optional).....	95
7 iSolarCloud App.....	96
7.1 Brief Introduction.....	96
7.2 Installing App.....	96
7.3 Login.....	97
7.3.1 Requirements.....	97
7.3.2 Login Procedure.....	97
7.4 Function Overview.....	101
7.5 Home.....	101
7.6 Run Information.....	103
7.7 Records.....	104
7.8 More.....	107
7.8.1 System Parameters.....	107
7.8.2 Operation Parameters.....	108
7.8.3 Power Regulation Parameters.....	109
7.8.4 Communication Parameters.....	115
7.8.5 Firmware Update.....	115
7.8.6 Grounding Detection.....	117
7.8.7 Password Changing.....	117
8 System Decommissioning.....	118
8.1 Disconnecting the Inverter.....	118
8.2 Dismantling the Inverter.....	118

8.3 Disposal of Inverter.....	119
9 Troubleshooting and Maintenance.....	120
9.1 Troubleshooting.....	120
9.2 Maintenance.....	128
9.2.1 Maintenance Notices.....	128
9.2.2 Quick Shutdown.....	129
9.2.3 Routine Maintenance.....	130
9.2.4 Cleaning Air Inlet and Outlet.....	130
9.2.5 Fan Maintenance.....	131
10 Appendix.....	134
10.1 Technical Data.....	134
10.2 Wring Distance of DI Dry Contact.....	143
10.3 Quality Assurance.....	144
10.4 Contact Information.....	145

1 Safety Instructions

When installing, commissioning, operating, and maintaining the product, strictly observe the labels on the product and the safety requirements in the manual. Incorrect operation or work may cause:

- Injury or death to the operator or a third party.
- Damage to the product and other properties.

WARNING

- **Do not perform any operation on the product (including but not limited to, handling, installing, powering on, or maintaining the product, performing electrical connection, and working at heights) in harsh weather conditions, such as thunder and lightning, rain, snow, and Level 6 or stronger winds. SUNGROW shall not be held liable for any damage to the device due to force majeure, such as earthquakes, floods, volcanic eruptions, mudslides, lightning strikes, fires, wars, armed conflicts, typhoons, hurricanes, tornadoes, and other extreme weathers.**
- **In case of fire, evacuate from the building or product area and call the fire alarm. Re-entry into the burning area is strictly prohibited under any circumstances.**

NOTICE

- **Tighten the screws with the specified torque using tools when fastening the product and terminals. Otherwise, the product may be damaged. And the damage caused is not covered by the warranty.**
- **Learn how to use tools correctly before using them to avoid hurting people or damaging the device.**
- **Maintain the device with sufficient knowledge of this manual and use proper tools.**



- The safety instructions in this manual are only supplements and cannot cover all the precautions that should be followed. Perform operations considering actual onsite conditions.
- SUNGROW shall not be held liable for any damage caused by violation of general safety operation requirements, general safety standards, or any safety instruction in this manual.
- When installing, operating, and maintaining the product, comply with local laws and regulations. The safety precautions in this manual are only supplements to local laws and regulations.
- During the product transport, installation, wiring, maintenance, etc., the materials and tools prepared by users must meet the requirements of applicable local laws and regulations, safety standards, and other specifications. SUNGROW shall not be held liable for any damage to the product caused by the adoption of materials and tools that fail to meet the above-mentioned requirements.
- Operations on the product, including but not limited to, handling, installing, wiring, powering on, maintenance, and use of the product, must not be performed by unqualified personnel. SUNGROW shall not be held liable for any damage to the product resulting from operations done by unqualified personnel.
- Where the transport of the product is arranged by users, SUNGROW shall not be held liable for any damage to the product that is caused by users themselves or the third-party transport service providers designated by the users.
- SUNGROW shall not be held liable for any damage to the product caused by the negligence, intent, fault, improper operation, and other behaviors of users or third-party organizations.
- SUNGROW shall not be held liable for any damage to the product arising from reasons unrelated to SUNGROW.

1.1 Unpacking and Inspection

WARNING

- **Check all safety signs, warning labels and nameplates on devices.**
- **The safety signs, warning labels and nameplates must be clearly visible and cannot be removed or covered before the device is decommissioned.**

NOTICE

After receiving the product, check whether the appearance and structural parts of the device are damaged, and check whether the packing list is consistent with the actual ordered product. If there are problems with the above inspection items, do not install the device and contact your distributor first. If the problem persists, contact SUNGROW in time.

1.2 Installation Safety

⚠ DANGER

- Make sure there is no electrical connection before installation.
- Before drilling, avoid the water and electricity wiring in the wall.

⚠ CAUTION

Improper installation may cause personal injury!

- If the product supports hoisting transport and is hoisted by hoisting tools, no one is allowed to stay under the product.
- When moving the product, be aware of the product weight and keep the balance to prevent it from tilting or falling.

NOTICE

Before operating the product, must check and ensure that tools to be used have been maintained regularly.

1.3 Electrical Connection Safety

⚠ DANGER

- Before electrical connections, please make sure that the inverter is not damaged, otherwise it may cause danger!
- Before electrical connections, please make sure that the inverter switch and all switches connected to the inverter are set to "OFF", otherwise electric shock may occur!

 DANGER

The PV string will generate lethal high voltage when exposed to sunlight.

- Operators must wear proper personal protective equipment during electrical connections.
- Must ensure that cables are voltage-free with a measuring instrument before touching DC cables.
- Respect all safety instructions listed in relevant documents about PV strings.
- The inverter must not be connected to a PV string that requires positive or negative grounding.

 DANGER

Danger to life due to a high voltage inside the inverter!

- Be sure to use special insulation tools during cable connections.
- Note and observe the warning labels on the product, and perform operations strictly following the safety instructions.
- Respect all safety instructions listed in this manual and other pertinent documents.

 WARNING

Damage to the product caused by incorrect wiring is not covered by the warranty.

- Electrical connection must be performed by professionals.
- All cables used in the PV generation system must be firmly attached, properly insulated, and adequately dimensioned.

⚠ WARNING

- Check the positive and negative polarity of the PV strings, and connect the PV connectors to corresponding terminals only after ensuring polarity correctness.
- During the installation and operation of the inverter, please ensure that the positive or negative poles of PV strings do not short-circuit to the ground. Otherwise, an AC or DC short-circuit may occur, resulting in equipment damage. The damage caused by this is not covered by the warranty.
- Do not connect any load between the inverter and the AC circuit breaker directly connected to it, so as to prevent the switch from tripping by mistake.
- Determine the specifications of AC circuit breakers strictly in compliance with the applicable local laws and regulations and safety standards or the recommendation by SUNGROW. Otherwise, the switch may not open in time in the event of something abnormal, which may then lead to safety incidents.

NOTICE

Comply with the safety instructions related to PV strings and the regulations related to the local grid.

1.4 Operation Safety

DANGER

When routing cables, ensure a distance of at least 30 mm between the cables and heat-generating components or areas to protect the insulation layer of cables from aging and damage.

When the product is working:

- Do not touch the product enclosure.
- It is strictly forbidden to plug and unplug any connector on the inverter.
- Do not touch any wiring terminal of the inverter. Otherwise, electric shock may occur.
- Do not disassemble any parts of the inverter. Otherwise, electric shock may occur.
- It is strictly forbidden to touch any hot parts of the inverter (such as the heat sink). Otherwise, it may cause burns.
- Do not connect or remove any PV string or any PV module in a string. Otherwise, electric shock may occur.
- If the inverter is equipped with a DC switch, do not operate it. Otherwise, it may cause device damage or personal injury.

Do not take other actions, such as setting parameters or cutting off power, during the process of inverter firmware update, to avoid update failure.

1.5 Maintenance Safety

DANGER

Risk of inverter damage or personal injury due to incorrect service!

- Before maintenance, disconnect the AC circuit breaker on the grid side and then the DC switch. If a fault that may cause personal injury or device damage is found before maintenance, disconnect the AC circuit breaker and wait until the night before operating the DC switch. Otherwise, a fire inside the product or an explosion may occur, causing personal injuries.
- After the inverter is powered off for 5 minutes, measure the voltage and current with professional instrument. Only when there is no voltage nor current can operators who wear protective equipment operate and maintain the inverter.
- Even if the inverter is shut down, it may still be hot and cause burns. Wear protective gloves before operating the inverter after it cools down.

 DANGER

Touching the power grid or the contact points and terminals on the inverter connected to the power grid may lead to electric shock!

- The power grid side may generate voltage. Always use a standard voltmeter to ensure that there is no voltage before touching.

 CAUTION

To prevent misuse or accidents caused by unrelated personnel, post prominent warning signs or demarcate safety warning areas around the product.

NOTICE

To avoid the risk of electric shock, do not perform any other maintenance operations beyond those described in this manual. If necessary, contact your distributor first. If the problem persists, contact SUNGROW. Otherwise, the losses caused is not covered by the warranty.

NOTICE

- If the paint on the inverter enclosure falls or rusts, repair it in time. Otherwise, the inverter performance may be affected.
- Do not use cleaning agents to clean the inverter. Otherwise, the inverter may be damaged, and the loss caused is not covered by the warranty.
- As the inverter contains no parts that can be maintained, never open the enclosure of the inverter or replace any internal components without authorization. Otherwise, the loss caused is not covered by the warranty.
- Do not open the maintenance door in rainy or snowy weather. If it is inevitable, take proper protective measures to avoid the ingress of rainwater and snow into the maintenance compartment; otherwise, the product's operation may be affected.
- Before closing the maintenance door, check whether there is any object left inside the maintenance compartment, such as screws, tools, etc.
- It is recommended for users to use cable sheathing to protect the AC cable. If the cable sheathing is used, make sure it is positioned inside the maintenance compartment.

1.6 Disposal Safety

WARNING

Please scrap the product in accordance with relevant local regulations and standards to avoid property losses or casualties.

2 Product Description

2.1 System Introduction

The inverter is a transformerless 3-phase PV grid-connected inverter. As an integral component in the PV power system, the inverter is designed to convert the direct current power generated from the PV modules into grid-compatible AC current and to feed the AC current into the utility grid.

The intended usage of the inverter is illustrated in the following figure.

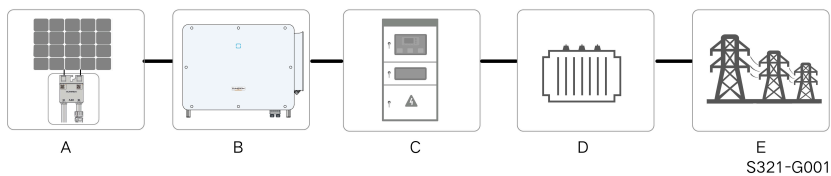

figure 2-1 Inverter Application in PV Power System

⚠ WARNING

**The inverter must not be connected to a PV string that requires positive or negative grounding.
Do not connect any local load between the inverter and the AC circuit breaker.**

NOTICE

**When designing the system, ensure that the operating ranges of all devices that are connected to the inverter meet the requirements of the inverter.
The PV modules in the system must comply with the IEC 61730-1 (2016) class II standard.
The inverter applies only to the scenarios described in this manual.**

Item	Description	Note
	PV strings	Monocrystalline silicon, polycrystalline silicon and thin-film without grounding.
A	Optimizer	Connected to the PV module by its input cable, the optimizer can track the module's maximum power and output the desired voltage through a DC/DC voltage conversion circuit.(only the SG125-P2 version of inverters support the installation of optimizers)
B	Inverter	SG125CX-P2, SG110CX-P2, SG75CX-P2

Item	Description	Note
C	Grid connection cabinet	Includes devices such as AC circuit breaker, SPD, metering device.
D	Transformer	Boost the low voltage from the inverter to grid-compatible medium voltage. (Optional)
E	Utility grid	The grid forms supported by the inverter are shown in the figure below.

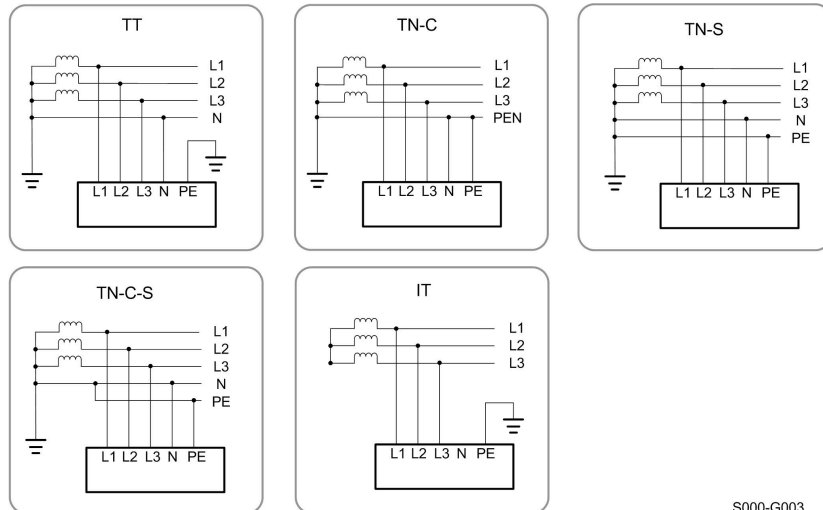

S000-G003

NOTICE

In a TT power grid, the N-PE voltage should be lower than 30 V.

If the inverter is connected to the IT grid (i.e., no N line connection), there may be a risk of single-phase over/under-voltage and single-phase high/low voltage ride through.

Please refer to the optimizer user manual for details.





Please contact your local sales staff to confirm that the optimizer is available for sale in your territory.

2.2 Product Introduction

Model Description

The model description is as follows (Take SG125CX-P2 as an example):

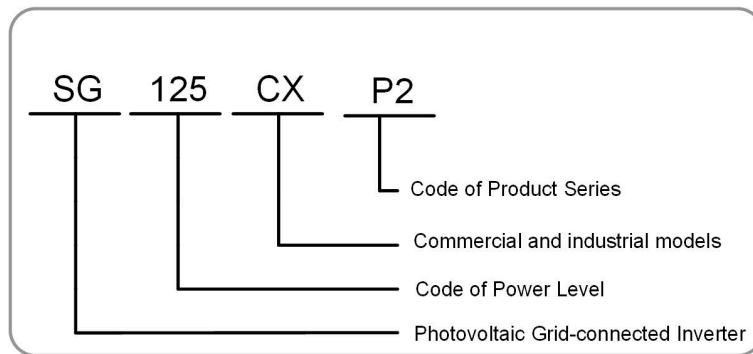

S321-G002

Appearance

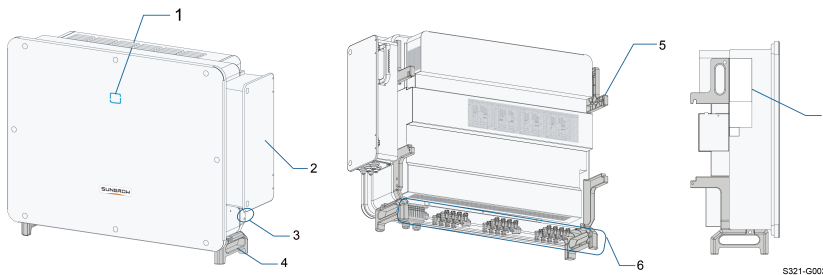

S321-G003

figure 2-2 Inverter Appearance

* The image shown here is for reference only. The actual product received may differ.

No.	Name	Description
1	LED indicator panel	HMI interface to indicate the present working state of the inverter.
2	AC junction box	Used to connect AC cables and the power cable for tracking system.
3	External protective grounding terminals	2, use at least one of them to ground the inverter.

No.	Name	Description
4	Bottom handles	2, used to move the inverter.
5	Mounting lugs	4, used to hang the inverter onto the mounting-bracket.
6	Wiring area	DC switches, DC terminals, and communication terminals. For details, refer to 5.2 Terminal Description
7	Labels	Warning symbols, nameplate, and QR code.

Dimensions

The following figure shows the dimensions of the inverter.

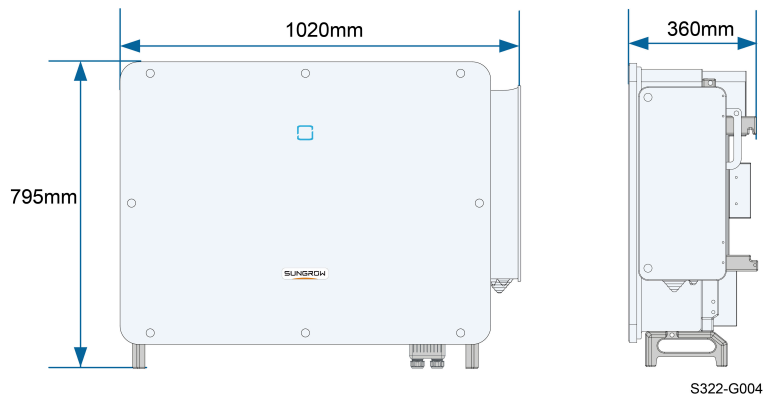











figure 2-3 Product Dimensions(in mm)

Weight

Model	Weight
SG125CX-P2	87 kg
SG110CX-P2	87 kg (93 kg for Australia)
SG75CX-P2	82 kg

2.3 Symbols on Product

Symbol	Explanation
	Do not dispose of the inverter together with household waste.
	TÜV mark of conformity.
	CE mark of conformity. EU/EEA Importer.



Symbol	Explanation
	Regulatory compliance mark.
	CGC-SOLAR mark of conformity.
	UKCA mark of conformity.
	Disconnect the inverter from all the external power sources before maintenance!
	Burn danger due to the hot surface that may exceed 60°C.
 	Danger to life due to high voltages! Do not touch live parts for 5 minutes after disconnection from the power sources. Only qualified personnel can open and maintain the inverter.
	External protective grounding terminal.
	Read the user manual before maintenance!



* The table shown here is for reference only. The actual product received may differ.

2.4 LED Indicator

The LED indicator on the front of the inverter indicates the working state of the inverter.

table 2-1 LED Indicator State Description

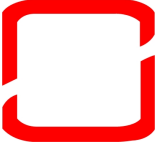
LED Color	State	Definition
 Blue	On	The device is connected to the grid and operating normally.
	Fast blink (Period: 0.2s)	The Bluetooth connection is established, and there is data communication.
		No system fault occurs.
	Slow blink (Period: 2s)	The device is in standby or startup state (not feeding power into the grid).

LED Color	State	Definition
	Slow blink once, blink three times	fast three The inverter is performing PID recovery.
	On	A fault occurs and the device cannot connect to the grid.
Red	Blink	The Bluetooth connection is established, data communication in process, and a system fault occurs.
	OFF	Both the AC and DC sides are powered down.
Gray		

WARNING

Voltage may still be present in AC side circuits after the indicator is off. Pay attention to the electricity safety when operating.

2.5 Circuit Diagram

The following figure shows the main circuit of the inverter.

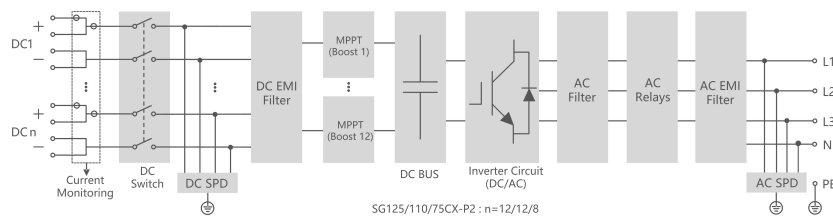

figure 2-4 Circuit Diagram

- DC Switches can safely disconnect the PV input when necessary to ensure the safe operation of the inverter and the safety of personnel.
- The DC SPD provides a discharge circuit for the DC side overvoltage to prevent it from damaging the internal circuits of the inverter.
- EMI filters can filter out the electromagnetic interference inside the inverter to ensure that the inverter meets the requirements of electromagnetic compatibility standards.
- The MPPT is used to ensure a maximum power from PV arrays at different PV input conditions.

- The Inverter Circuit converts the DC power into grid-compliant AC power and feeds it into the grid.
- The AC filter filters the output AC component of high frequency to ensure that the output current meets the grid requirements.
- The AC relay isolates the AC output of the inverter from the grid, making the inverter safe from the grid in case of inverter failure or grid failure.
- The AC SPD provides a discharge circuit for the AC side overvoltage to prevent it from damaging the internal circuits of the inverter.

DANGER

If the lightning level exceeds the protection level of the product, surge protection and overvoltage protection may fail, resulting in electric shock and fatal injury!

2.6 Function Description

The inverter is equipped with the following functions:

Conversion Function

The inverter converts the DC into grid-compatible AC and feeds the AC into the grid.

Data Storage and Display

The inverter logs system information like running information, error records, etc.

Parameter Configuration

The inverter provides various parameter configurations. Users can set parameters via the App to meet different needs and optimize the inverter performance.

Communication Interface

The inverter is designed with standard RS485 communication interfaces and communication accessory port.

- The standard RS485 communication interfaces are used to establish communication with monitoring devices and to upload monitoring data to a monitoring background through communication cables.
- The communication accessory port is used to connect communication module manufactured by SUNGROW, and upload monitoring data by means of wireless communication.

The inverter can be connected to communication devices via either of the two interfaces. When communication is established between the inverter and the communication devices, users can view inverter information or set inverter parameters, such as running parameter and protection parameter, through the iSolarCloud.



It is recommended to use the communication module from SUNGROW. Using a device from other companies may lead to communication failure or other unexpected damage.

Protection Function

The inverter is equipped with anti-island protection, LVRT/HVRT, DC reversed polarity protection, AC short circuit protection, leakage current protection, DC over-voltage/over-current protection, etc.

PID Recovery



The PID function may not be applicable in some areas. Please consult SUNGROW for details.

The PID effect (Potential Induced Degradation) of PV modules will cause serious damage to generated output and yield, which can be avoided or recovered by PID recovery function.

- For positive voltage scheme, after the PID is enabled, the voltage to ground of all PV strings is greater than 0, and therefore the PV string-to-ground voltage is a positive value.

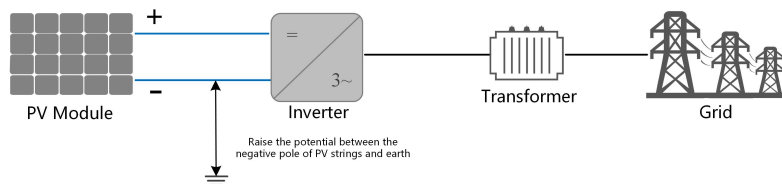

- For negative voltage scheme, after the PID is enabled, the voltage to ground of all PV strings is lower than 0, and therefore the PV string-to-ground voltage is a negative value.

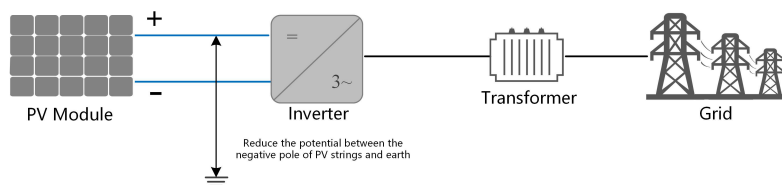

NOTICE

- **Before enabling the PID recovery function, make sure the voltage polarity of the PV modules to ground meets requirement. If there are any questions, contact the PV module manufacturer or read the corresponding user manual.**
- **If the voltage scheme for the PID protection / recovery function does not meet the requirement of corresponding PV modules, the PID will not work as expected or even damage the PV modules.**
- **If the PID recovery function is enabled, it only works at night.**
- **PID recovery function and reactive power generation at night cannot be enabled at the same time.**
- **After the PID recovery function is enabled, the voltage of the PV string to ground is 500Vdc by default.**
- **When the inverter is in the PID recovery state (the indicator blinks blue once at long intervals and blinks at short intervals for three times), disable the PID recovery in the iSolarCloud App before manually powering on and maintaining the inverter.**

AFCI Function

The AFCI function may not be applicable in some areas. Please consult SUNGROW for details.

- AFCI activation

This function can be enabled to detect whether arc occurs in the DC circuit of the inverter.

- AFCI self-test

This function is intended to detect whether the AFCI function of the inverter is normal.

Optimizer Functions

- Module-level MPPT

Increase the power generation of the PV system by continuously tracking the maximum power point of the PV module.

- Module-level shutdown

Quickly reduce module voltage.

- Module-level monitoring

The optimizer can monitor the performance of modules.

- Module-level IV curve diagnosis

The optimizer can scan the module IV curve and judge whether a module fault occurs. And in this case the inverter cannot perform string-level IV curve scan.

The Module-level IV curve diagnosis function can only be used on iSolarCloud Web. At most six modules can be selected in one round of Module-level IV curve diagnosis.

3 Unpacking and Storage

3.1 Unpacking and Inspection

The product is thoroughly tested and strictly inspected before delivery. Nonetheless, damage may still occur during shipping. For this reason, please conduct a thorough inspection after receiving the product.

- Check the packing case for any visible damage.
- Check the scope of delivery for completeness according to the packing list.
- Check the inner contents for damage after unpacking.

Contact SUNGROW or the transport company in case of any damage or incompleteness, and provide photos to facilitate services.

Do not dispose of the original packing case. It is recommended to store the device in the original packing case when the product is decommissioned.

NOTICE

After receiving the product, check whether the appearance and structural parts of the device are damaged, and check whether the packing list is consistent with the actual ordered product. If there are problems with the above inspection items, do not install the device and contact your distributor first. If the problem persists, contact SUNGROW in time.

If any tool is used for unpacking, be careful not to damage the product.

3.2 Inverter Storage

Proper storage is required if the inverter is not installed immediately.

- Store the inverter in the original packing case with the desiccant inside.
- The storage temperature must be always between -40°C and $+70^{\circ}\text{C}$, and the storage relative humidity must be always between 0 and 95 %, non-condensing.
- In case of stacking storage, the number of stacking layers should never exceed the limit marked on the outer side of the packing case.
- The packing case should be upright.
- If the inverter needs to be transported again, pack it strictly before loading and transporting it.
- Do not store the inverter in places susceptible to direct sunlight, rain, and strong electric field.

- Do not place the inverter in places with items that may affect or damage the inverter.
- Store the inverter in a clean and dry place to prevent dust and water vapor from eroding.
- Do not store the inverter in places with corrosive substances or susceptible to rodents and insects.
- Carry out periodic inspections. Inspection shall be conducted at least once every six months. If any insect or rodent bites are found, replace the packaging materials in time.
- If the inverter has been stored for more than a year, inspection and testing by professionals are required before it can be put into operation.

NOTICE

Please store the inverter according to the storage requirements. Product damage caused by failure to meet the storage requirements is not covered by the warranty.

4 Mechanical Mounting

WARNING

Respect all local standards and requirements during mechanical installation.

4.1 Safety During Mounting

DANGER

Make sure there is no electrical connection before installation.
Before drilling, avoid the water and electricity wiring in the wall.

WARNING

For specific requirements for the installation environment, see [4.2.1 Installation Environment Requirements](#). In case the environment where the product is installed does not meet the requirements, SUNGROW shall not be held liable for any property damage arising therefrom.

CAUTION

Improper handling may cause personal injury!

- When moving the product, be aware of its weight and keep the balance to prevent it from tilting or falling.
- Wear proper protective equipment before performing operations on the product.
- The bottom terminals and interfaces of the product cannot directly contact the ground or other supports. The product cannot be directly placed on the ground.

NOTICE

- During installation, ensure that no device in the system causes it hard for the DC switch and the AC circuit breaker to act or hinders maintenance personnel from operating.
-
- If drilling is required during installation:
 - Wear goggles and protective gloves when drilling holes.
 - Make sure to avoid the water and electricity wiring in the wall before drilling.
 - Protect the product from shavings and dust.

4.2 Location Requirements

To a large extent, a proper installation location ensures safe operation, service life, and performance of the inverter.

- The inverter with protection rating IP66 can be installed both indoors and outdoors.
- The inverter should be installed at a height that allows easy viewing of the LED indicator panel, as well as easy electrical connection, operation and maintenance.

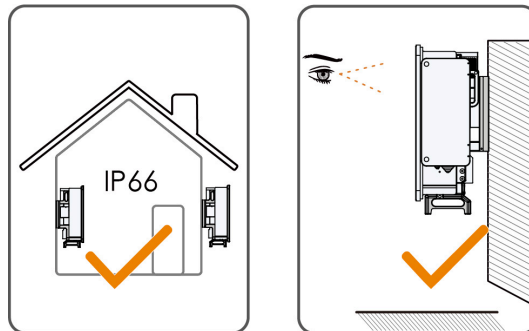

4.2.1 Installation Environment Requirements

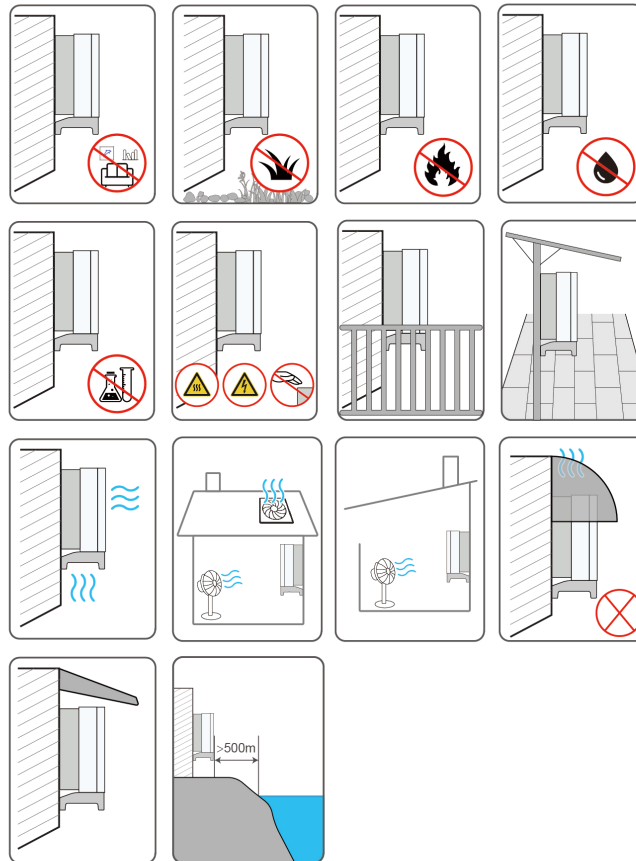

- The inverter produces noise during operation, thus it is not recommended to install it in places for residential purpose. If this cannot be avoided, it is recommended to install the inverter in a place over 25 meters away from the residential area, or take noise mitigation measures.
- If the inverter is installed in a place with lush vegetation, weed on a regular basis. In addition, the ground beneath the inverter needs to undergo certain treatment, such as laying cement or gravel, etc. (an area of 3m×2.5m is recommended).
- Do not install the inverter in an environment with flammables, explosives, or smoke.
- Do not install the inverter in places prone to water leak, e.g., under the air-conditioner vent, the air vent, or the cable outlet window of the machine room, so as to prevent device damage or short circuit caused by intrusion of water.

- Do not install the inverter in a place with corrosives such as corrosive gas and organic solvent, etc.
- When the inverter is running, its surface may carry high voltages or get very hot. Do not touch it; otherwise, it may lead to burns or electric shocks.
- Do not install the inverter in a place that is easy to reach for people.
- If the inverter needs to be installed in a closed or semi-closed environment, please install additional heat dissipation or ventilation devices. Furthermore, while the inverter is operating, ensure the indoor ambient temperature does not exceed the outdoor ambient temperature. A semi-closed environment refers to a special space where natural ventilation is limited and gas or heat may easily accumulate, although it is not fully enclosed on all six sides.
- The installation site must have solid ground, free of rubber-like soils (which cannot be effectively compacted) or weak soils, and should not be prone to subsidence. Also, avoid low-lying areas where water or snow may easily accumulate. Ensure the site is located above the highest recorded water level in the area.
- Do not install the inverter in a position that could be flooded.
- To prevent vegetation or water on the ground from impacting inverter operation, if the space above meets the designated requirements, elevate the inverter to an appropriate height.
- Install the inverter in a place with shelter, so as to prevent it from getting impacted by direct sunlight and severe weather (e.g. snow, rain, and lightning). The inverter will derate in high temperatures for self-protection. If installed in a place directly exposed to sunlight, as the temperature rises, the inverter may witness power reduction.
- Good heat dissipation is very important to the inverter. Please install the inverter in a ventilated environment.
- If the inverter needs to be installed in a closed or semi-closed environment, please install additional heat dissipation or ventilation devices. Furthermore, while the inverter is operating, ensure the indoor ambient temperature does not exceed the outdoor ambient temperature. A semi-closed environment refers to a special space where natural ventilation is limited and gas or heat may easily accumulate, although it is not fully enclosed on all six sides.
- Please consult SUNGROW before installing inverters outdoors in areas prone to salt damage, which mainly are coastal areas within 500 meters of the coast. The sedimentation amount of salt spray is correlated to the characteristics of the seawater, sea winds, precipitation, air humidity, topography, and forest coverage in the adjacent sea areas, and there are substantial differences between different coastal areas.
- Do not install the inverter in an environment contaminated with chemicals such as halogen and sulfide.
- Do not install the inverter in an environment with vibration and strong electromagnetic field. Strong-magnetic-field environments refer to places where magnetic field strength measures over 30 A/m.

- In dusty environments such as places full of dust, smoke, or floc, particles may cling to the device's air outlet or heat sink, thus impacting its heat dissipation performance or even getting it damaged. Therefore, do not install the inverter in dusty environments. If the inverter has to be installed in such environments, please clean its fans and heat sink on a regular basis to ensure a good heat dissipation performance.
- The average temperature approximately 1 m around the inverter should be taken as its operating temperature. The temperature and humidity should meet the requirements below:

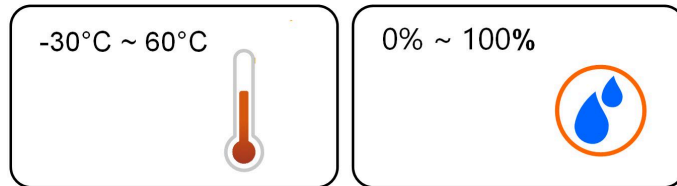

4.2.2 Carrier Requirements

The mounting structure where the inverter is installed must comply with local/national standards and guidelines. Ensure that the installation surface is solid enough to bear four times the weight of the inverter and is suitable for the dimensions of the inverter (e.g. cement walls, plasterboard walls, etc.).

Do not install the inverter on a carrier that may vibrate in resonance, so as to avoid making bigger noise.

The structure should meet the following requirements:

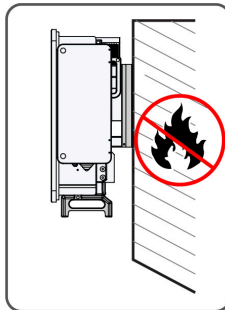

4.2.3 Angle Requirements

Install the inverter vertically or at the maximum allowable rear tilt angle. Do not install the inverter horizontally, forward, excessively backward, sideways, or upside down.

Inverters in floating plants cannot be installed at a back tilt.

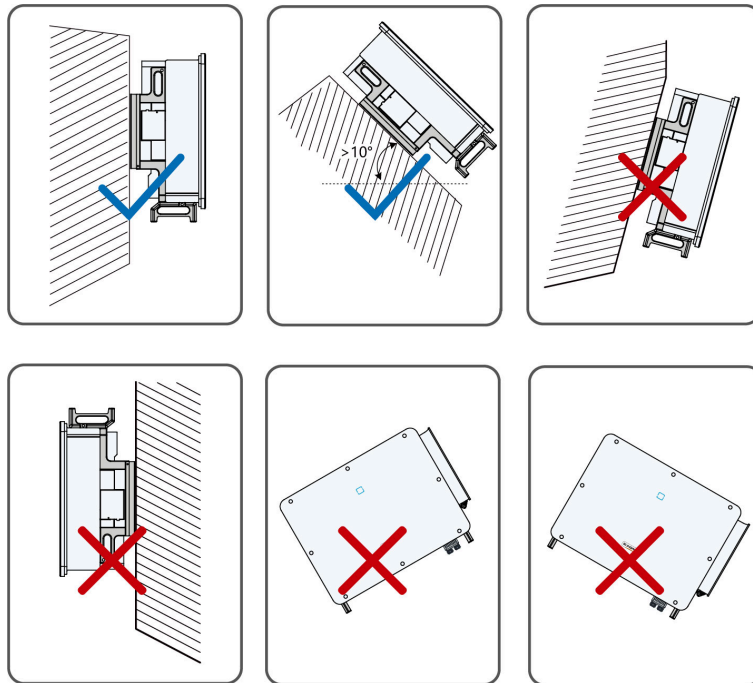

tilting backwards installation requirements

In case the installation site is a level surface, mount the inverter to the horizontal-mounting bracket to meet the mounting angle requirements, as shown in the figure below.

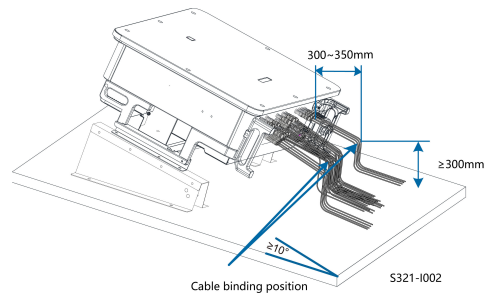

Take the following items into account when designing the bracket scheme:

- Consider onsite climate conditions and take anti-snow and anti-rain measures if necessary.
- Ensure that the waterproof connectors are at least 300mm higher than the ground surface.
- Bind the cables at the positions 300~350mm away from the DC connector and communication waterproof terminal.
- The various waterproof terminals should be tightened with the torque specified in this manual to ensure that they are securely sealed.

4.2.4 Clearance Requirements

Spacing for installing an inverter

Reserve enough clearance around the inverter to ensure sufficient space for heat dissipation.

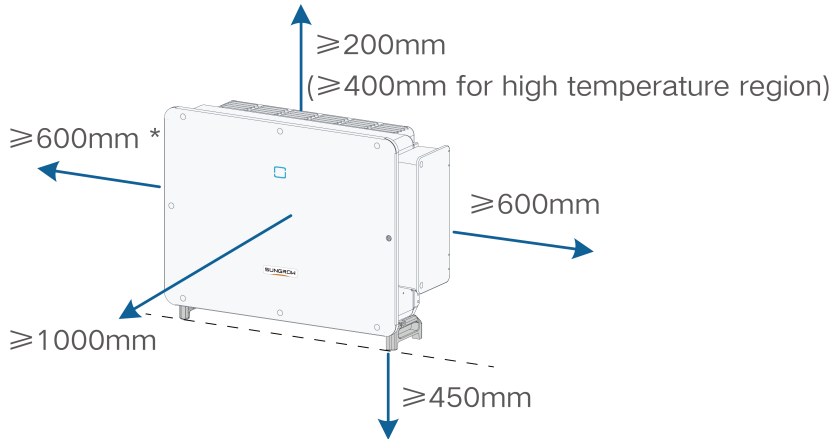

* In case this distance is less than the distance in the diagram, move the inverter from the mounting-bracket or wall before maintaining fans.

* High-temperature area: Areas where the highest average temperature exceeds 35°C in at least one month of a year.

Spacing for installing multiple inverters

In case of multiple inverters, reserve specific clearance between the inverters. For other installation scenarios, please refer to the relevant technical documents on <http://support.sungrow-power.com/>.

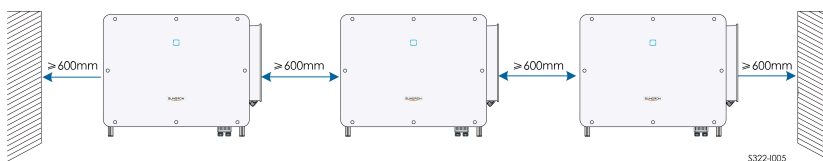

Back to Back Installation

When installing inverters back-to-back, the distance between every two inverters should be at least 600 mm.



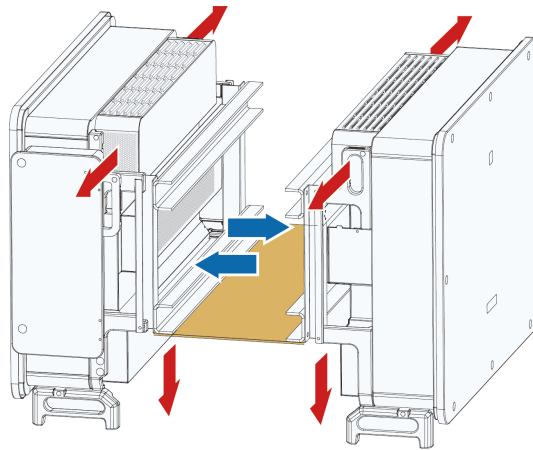





Add a baffle between the two inverters to form a heat dissipation channel. The baffle plate should be placed horizontally between two inverters and should not block the air outlet of inverters.

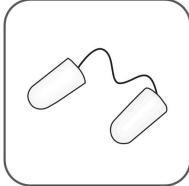
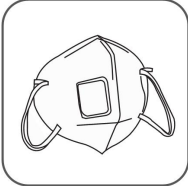

4.3 Installation Tools

Installation tools include but are not limited to the following recommended ones. If necessary, use other auxiliary tools on site.

table 4-1 Tool specification

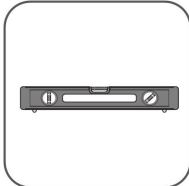
			
Goggles	Earplugs	Dust mask	Safety gloves
			
Safety shoes	Utility knife	Slotted screwdriver (M2, M3, M6)	Phillips screwdriver (M4, M6, M8)
			
Hammer drill ($\phi 12$)	Pliers	Marker	Level

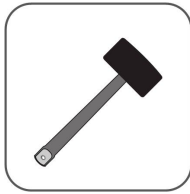

Rubber mallet

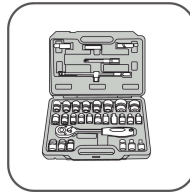
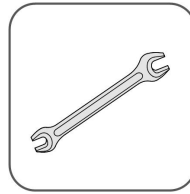
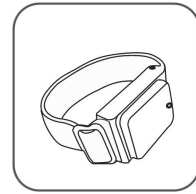
Socket wrench set
(M4, M8, M12)Open-end wrench
(16 mm, 33 mm)

Anti-static wrist strap



Wire cutter

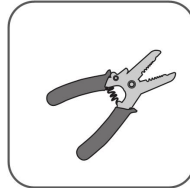

Wire stripper

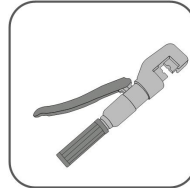

Hydraulic plier

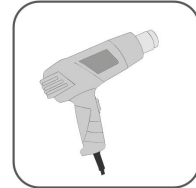

Heat gun

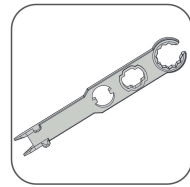
Crimping tool
4–6mm²

Connector wrench

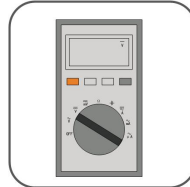
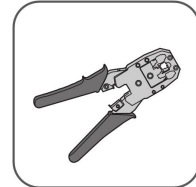
Multimeter
≥ 1100 Vdc

RJ45 crimping tool



Vacuum cleaner

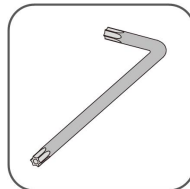

Allen wrench

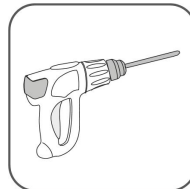

Electric drill (φ12)



Scissors

4.4 Moving Inverter

Before installation, remove the inverter from the packing case and move it to the installation site.

It is recommended to use the four screw-in handles and the Bottom handles to move the inverter. Attach the four screw-in handles to the inverter lugs and base. Lift and move the inverter to its destination by means of the bottom handles and the four installed handles.

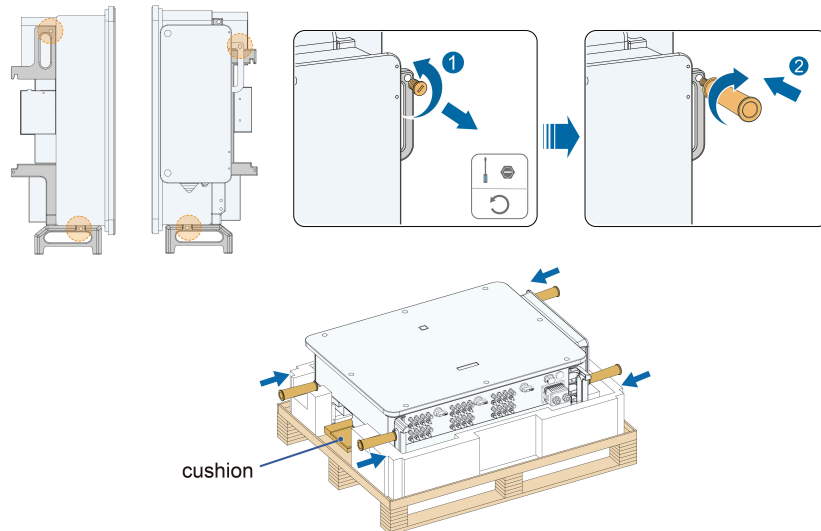

⚠ CAUTION

Improper handling may cause personal injury!

- Arrange an appropriate number of personnel to carry the inverter according to its weight, and installation personnel should wear protective equipment such as anti-impact shoes and gloves.
- Attention must be paid to the center of gravity of the inverter to avoid tilting during handling.
- Placing the inverter directly on a hard ground may cause damage to its metal enclosure. Protective materials such as sponge pad or foam cushion should be placed underneath the inverter.
- Move the inverter by holding the handles on it. Do not move the inverter by holding the terminals.

4.5 Installing Mounting-bracket

Inverter is installed on the wall and bracket by means of mounting bracket. The expansion plug set shown below is recommended for the installation.

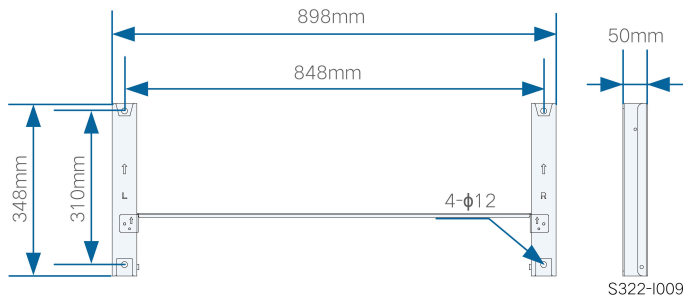
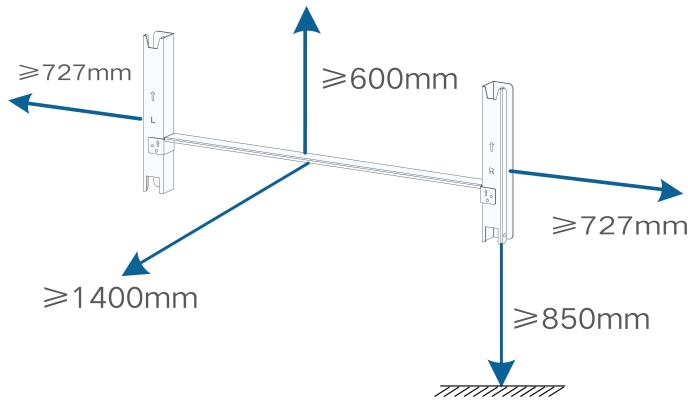

figure 4-1 Dimensions of Mounting-bracket

Reserve enough space when installing the mounting-bracket to meet the installation space requirements of the inverter.



4.5.1 PV Bracket-Mounted Installation

Tools

Item	Specification
Phillips screwdriver / electric screw driver	M4
Marker	-
Level	-
Electric drill	Drill bit: $\phi 12$
Wrench	Opening: 16 mm

Spare parts

Item	Quantity	Specification	Source
Grub screw	2	M4×10	Delivery scope
Bolt assembly	4	M10	Delivery scope

step 1 Assemble the mounting-bracket.

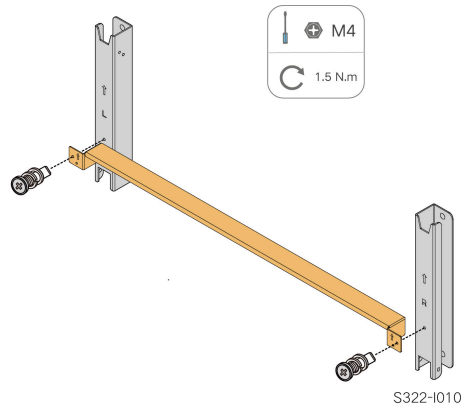

step 2 Level the assembled mounting-bracket by using the level, and mark the positions for drilling holes on the PV bracket. Drill the holes by using a electric drill.

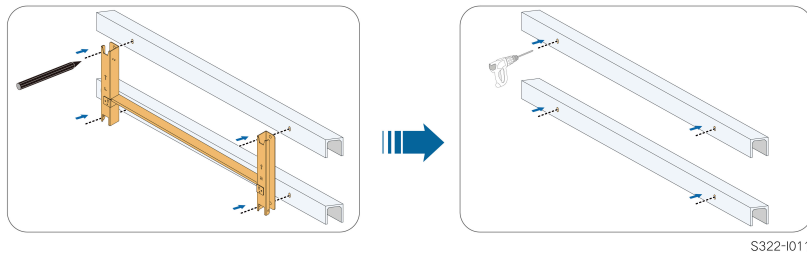

step 3 Secure the mounting-bracket with bolts.

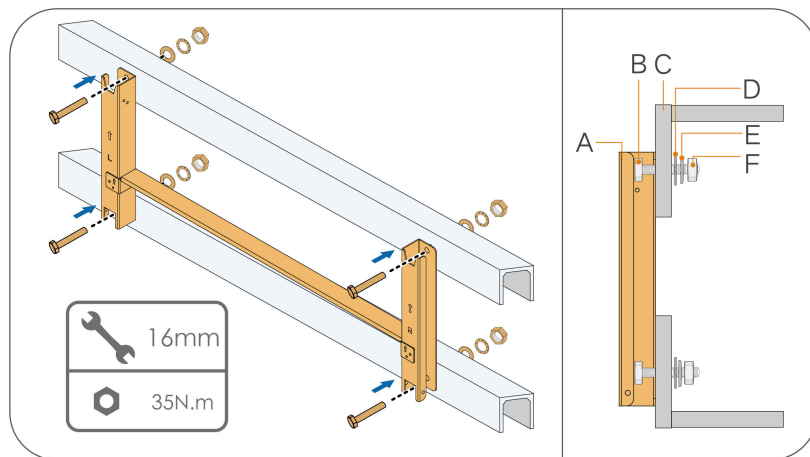

- (A) Mounting-bracket (B) Full threaded bolt (C) Metal bracket
 (D) Flat washer (E) Spring washer (F) Hex nuts

-- End

4.5.2 Wall-Mounted Installation

Tools

Item	Specification
Phillips screwdriver / electric screw driver	M4
Marker	-
Level	-
Hammer drill	Drill bit: $\phi 12$
wrench	Opening: 16mm

Spare parts

Item	Quantity	Specification	Source
Grub screw	2	M4×10	Delivery scope
Bolt assembly	4	M10×95 (Recommended)	Self-prepared

step 1 Assemble the mounting-bracket.

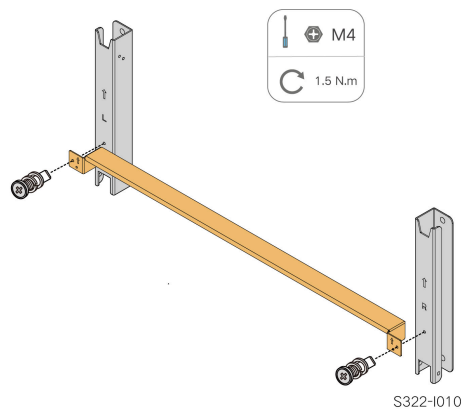

step 2 Level the assembled mounting-bracket by using the level, and mark the positions for drilling holes.

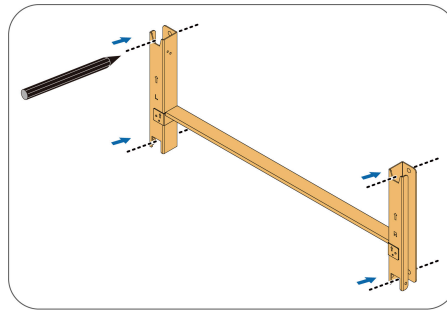

S322-I013

step 3 Insert the expansion bolts into the holes and secure them with a rubber hammer. Fasten the nut with a wrench to expand the bolt. Remove the nut, spring washer, and flat washer, and store them properly.

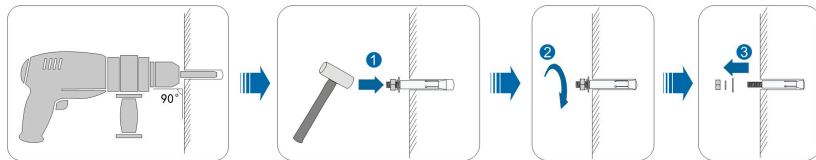

After removing the nut, spring washer, and flat washer, level the front of the expansion tube with the wall. Otherwise, the mounting brackets will not stay steady on the wall.

step 4 Install the mounting-bracket to the wall with the expansion bolts with the expansion bolts.

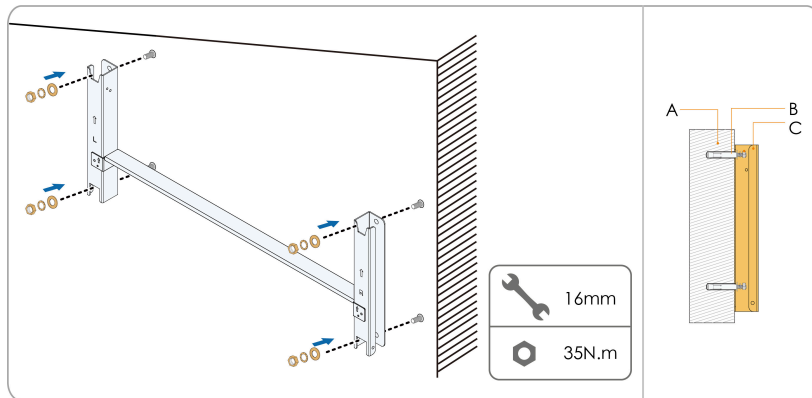

S322-I014

(A) Wall

(B) Expansion bolt

(C) Mounting-bracket

-- End

4.5.3 Pole-Mounting

Tools

Item	Specification
Phillips screwdriver / electric screw driver	M4
Marker	—
Level	—
Electric drill *	Drill bit: $\phi 12$
wrench	Opening: 16 mm

* Check whether other tools are needed according to the specification of clamp bolts.

Spare parts

Item	Quantity	Specification	Source
Grub screw	2	M4×10	Delivery scope
Bolt assembly	4	M10	Delivery scope
Nut assembly	4	M10	Self-prepared
U-beam	2	—	Self-prepared
Clamp	3	Determined by pole size	Self-prepared

step 1 Bury the pole into the installation site.



Please skip this step if the inverter is to be installed on a concrete post, PV bracket, etc.

step 2 Assemble the mounting-bracket.

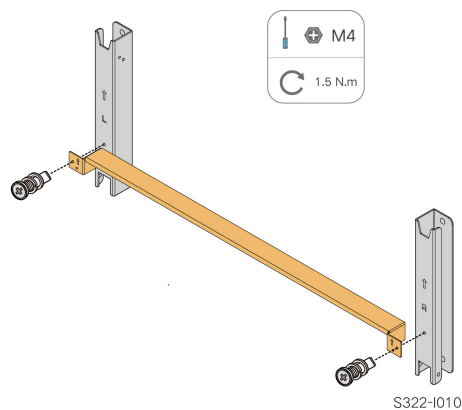

step 3 Mark and punch holes in the U-beam according to the dimensions shown below.

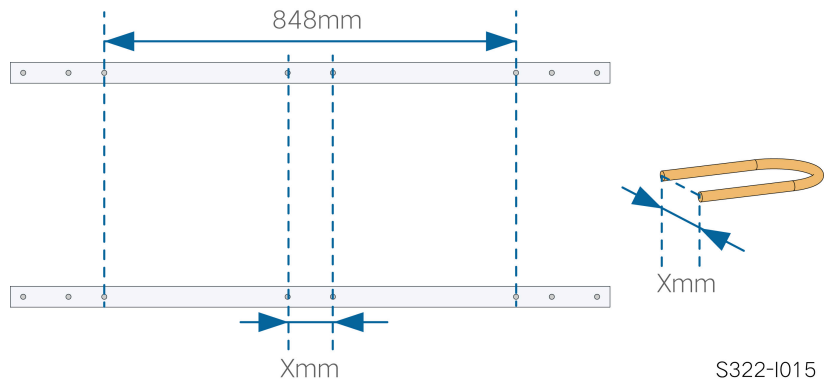

step 4 Use bolts and clamps to fix the U-beam to the pole.

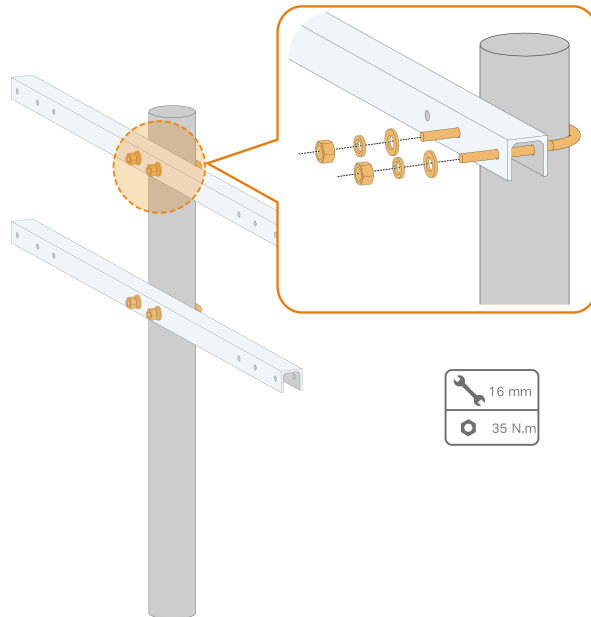

step 5 Use bolts to secure the mounting-bracket to the U-beam.

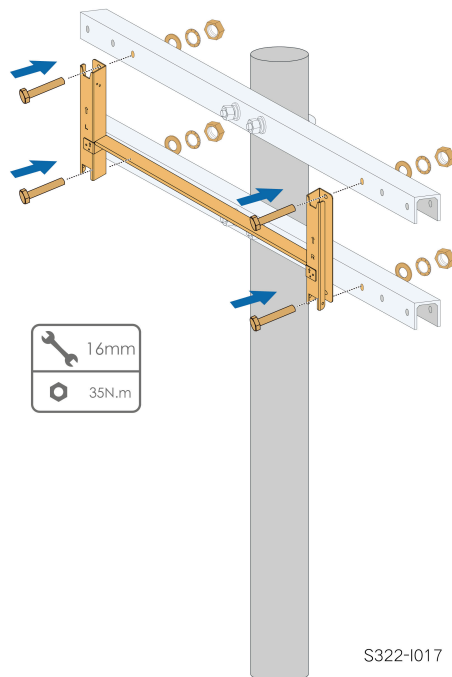

-- End

4.6 Installing Inverter

Tools

Item	Specification
Phillips screwdriver / electric screw driver	M6

Spare parts

Item	Quantity	Specification	Source
Grub screw	2	M6×65	Delivery scope

step 1 Take out the inverter from the packing case.

step 2 Hang the inverter to the mounting-bracket and ensure that the mounting ears perfectly engage with the mounting-bracket.

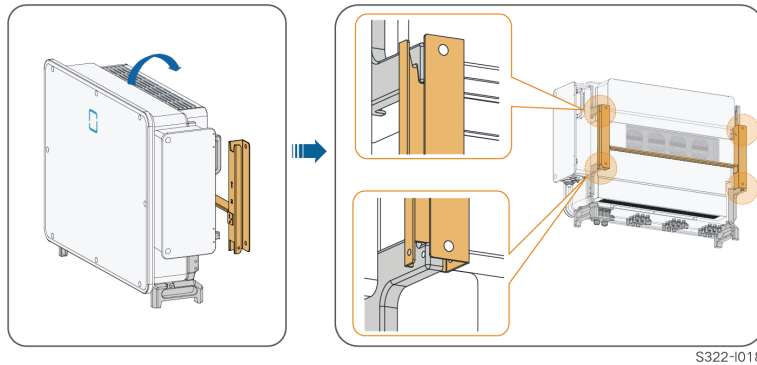

S322-I018

step 3 Fix the inverter with screws.

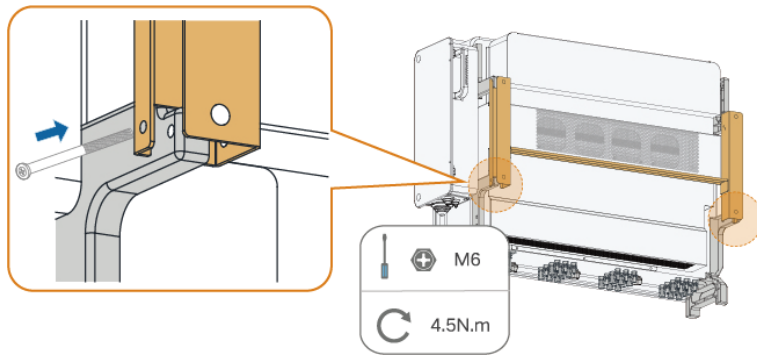

NOTICE

It is necessary to fix the left and right sides of the inverter with screws. Otherwise, the inverter may be unstable.

-- End

4.7 Installing Optimizer(Optional)

As shown in the figure below, clamp the optimizer parallel to the back of the PV module by clips.

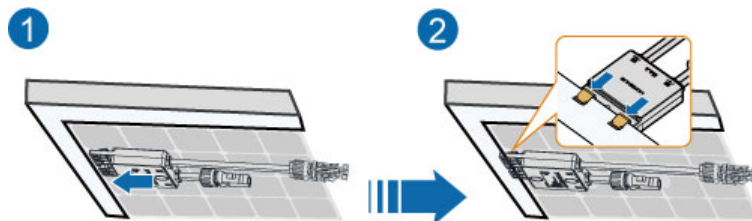

Full configuration is supported, and partial configuration is not supported. The full configuration scenario and and partial configuration scenario are shown below:

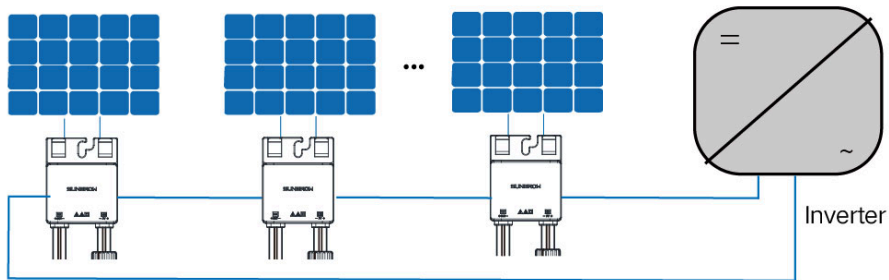
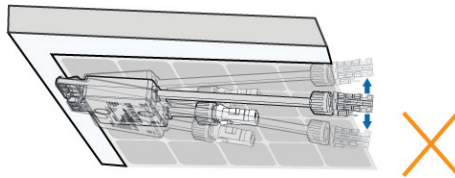

figure 4-2 Optimizers Configured for All PV Modules

NOTICE

- Do not forcibly bend the clips when installing the optimizer by clips. Otherwise, the clip may be damaged.



- Do not clamp the optimizer into holes in the module frame during installation. Otherwise, the optimizer cannot be removed or the clips may be damaged.

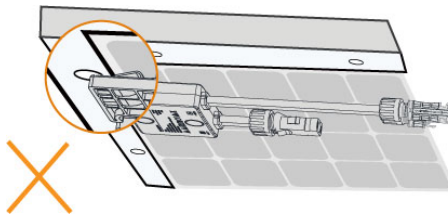

- It is recommended to install optimizers on the same side of modules.
- Do not clamp and remove the optimizer multiple times. Otherwise, the clip may become loose, affecting normal use.



Where the inverter's DC switch needs to be turned off due to maintenance or other reasons, if the system is equipped with optimizers, please turn off all the DC switches. After maintenance, turn on all the DC switches in the correct order before starting the device again.

5 Electrical Connection

5.1 Safety Instructions

 **DANGER**

The PV string will generate lethal high voltage when exposed to sunlight.

- Operators must wear proper personal protective equipment during electrical connections.
- Must ensure that cables are voltage-free with a measuring instrument before touching DC cables.
- Respect all safety instructions listed in relevant documents about PV strings.

 **DANGER**

- Before electrical connections, please make sure that the inverter switch and all switches connected to the inverter are set to "OFF", otherwise electric shock may occur!
- Ensure that the inverter is undamaged and all cables are voltage free before performing electrical work.
- Do not close the AC circuit breaker until the electrical connection is completed.

⚠ WARNING

Do not damage the ground conductor. Do not operate the product in the absence of a properly installed ground conductor. Otherwise, it may cause personal injury or product damage.

Please use measuring devices with an appropriate range. Overvoltage can damage the measuring device and cause personal injury.

Damage to the product caused by incorrect wiring is not covered by the warranty.

- **Electrical connection must be performed by professionals.**
- **Operators must wear proper personal protective equipment during electrical connections.**
- **All cables used in the PV generation system must be firmly attached, properly insulated, and adequately dimensioned. Cables used shall comply with the requirements of local laws and regulations.**
- **The factors that affect cable selection include rated current, cable type, routing mode, ambient temperature, and maximum expected line loss.**

NOTICE

All electrical connections must comply with local and national/regional electrical standards.

- **Cables used by the user shall comply with the requirements of local laws and regulations.**
- **Only with the permission of the national/regional grid department, the inverter can be connected to the grid.**

NOTICE

- **Install the external protective grounding cable first when performing electrical connection and remove the external protective grounding cable last when removing the inverter.**
- **Keep the AC output cable and the DC input cable close to each other during electrical connection.**
- **Comply with the safety instructions related to PV strings and the regulations related to the utility grid.**

NOTICE

- After being crimped, the OT terminal must wrap the wires completely, and the wires must contact the OT terminal closely.
- When using a heat gun, protect the device from being scorched.
- Keep the PV+ cable and PV– cable close to each other when connecting DC input cables.
- Before connecting a power cable (such as the AC cable, the DC cable, etc.), confirm that the label and identifier on the power cable are correct.
- When laying out communication cables, separate them from power cables and keep them away from strong interference sources to prevent communication interruption.
- All vacant terminals must be covered with waterproof covers to prevent affecting the protection performance.
- Ensure that AC output cables are firmly connected. Failing to do so may cause inverter malfunction or damage to its AC connectors.
- When the wiring is completed, seal the gap at the cable inlet and outlet holes with fireproof/waterproof materials such as fireproof mud to prevent foreign matter or moisture from entering and affecting the long-term normal operation of the inverter.



The cable colors in figures in this manual are for reference only. Please select cables according to local cable standards.

5.2 Terminal Description

All electrical terminals are located at the side and bottom of the inverter.

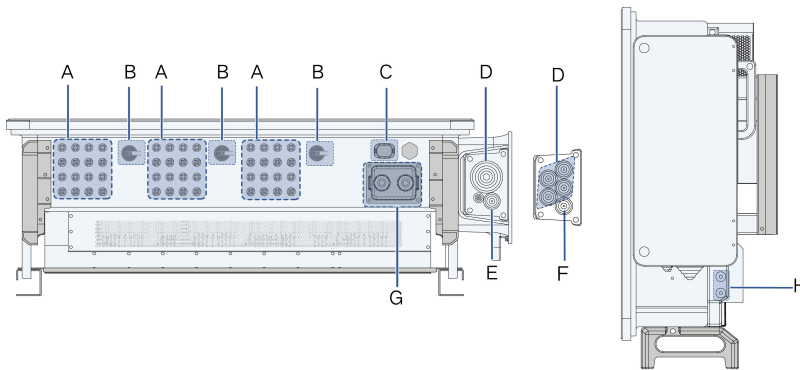

figure 5-1 Terminal Description(SG125/110CX-P2)

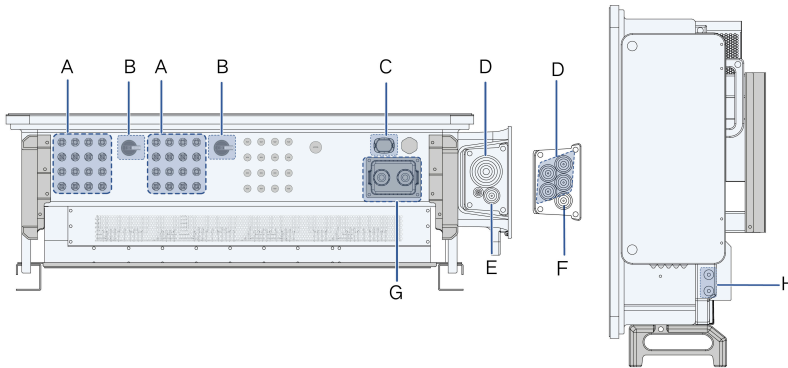



figure 5-2 Terminal Description(SG75CX-P2)

* The image shown here is for reference only. The actual product received may differ.

Item	Terminal	Mark	Note
A	PV terminals	+ / -	24 pairs of terminals(SG125/110CX-P2) 16 pairs of terminals (SG75CX-P2)
B	DC Switch	DC SWITCH	Used to switch on and off the DC input.
C	Communication terminal	COM3	For communication module connection.
D	AC wiring terminal	—	Used for AC output cable connection.
E	Standby grounding terminal*	—	Used for internal grounding.
F	PE terminal	—	Used for internal grounding.
G	Communication terminal	COM1,COM2	RS485 communication, digital input/output DI/DO, etc.

Item	Terminal	Mark	Note
H	External protective grounding terminal		use at least one of them to ground the inverter.

*If the PE cable is an independent single-core cable, it should be inserted into the AC junction box through the standby grounding terminal.

5.3 Electrical Connection Overview

The electrical connection should be realized as follows:

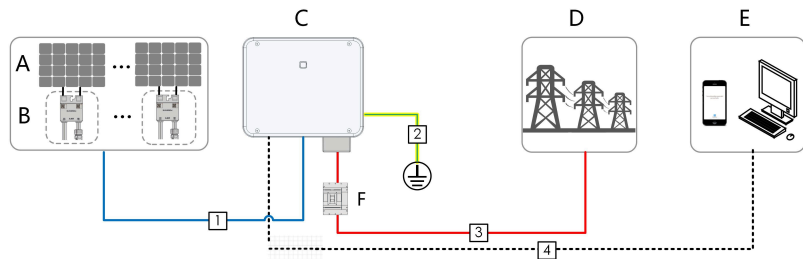

- (A) PV string
- (B) Optimizer(optional)
- (C) Inverter
- (D) Grid
- (E) Monitoring device
- (F) AC circuit breaker

table 5-1 Cable Requirements

No.	Cable	Type	Specification	
			Cable Diameter(mm)	Cross-sectional Area(m-m ²)
1	DC cable	PV cable complying with 1,100V standard	4.7 ~ 6.4	4 ~ 6
2	Power cable for tracking system	Outdoor two-core copper wire cable	8 ~ 18	0.5 ~ 10 (recommended range: 4 ~ 6)
3	Additional grounding cable	Outdoor single-core copper wire cable	The same as that of the PE wire in the AC cable	

No.	Cable	Type	Specification	
			Cable Diameter(mm)	Cross-sectional Area(m ²)
4	AC cable	Outdoor five-core copper wire cable	30 ~ 60	L1, L2, L3, N wire: 70 ~ 240 ⁽³⁾⁽⁴⁾ PE wire: refer to table 5-2 PE Wire Requirements
		Outdoor four-core wire copper cable	L1, L2, L3, N wire: 30 ~ 60	PE wire: refer to table 5-2 PE Wire Requirements
		Outdoor PE cable	PE wire: 14 ~ 32	
		Outdoor five-core aluminum wire cable ⁽¹⁾	30 ~ 60	L1, L2, L3, N wire: 70 ~ 240
		Outdoor four-core aluminum wire cable ⁽¹⁾	L1, L2, L3, N wire: 30 ~ 60	PE wire: refer to table 5-2 PE Wire Requirements
		Outdoor PE cable	PE wire: 14 ~ 32	
5	Communication cable	Five single-core outdoor copper cables	14 ~ 32	L1, L2, L3, N wire: 70 ~ 240 ⁽³⁾ PE wire: refer to table 5-2 PE Wire Requirements
		Four single-core outdoor aluminum cables ⁽¹⁾⁽²⁾	14 ~ 32	L1, L2, L3, N wire: 120 ~ 240 PE wire: refer to table 5-2 PE Wire Requirements
		Outdoor PE cable		
5	Communication cable	Shielded twisted pair (terminal block)	4.5 ~ 18	0.2 ~ 1.5
		CAT-5 Ethernet cable (RJ45)		/

Note(1):A copper to aluminum adapter terminal is required when an aluminum cable is used. For details, refer to [Aluminum Cable Requirements](#).

Note(2):In the case of five single-core cables, a spare AC sealing plate accessory is required as shown in the following figure. To purchase the AC sealing plate accessory, contact your distributor. If the distributor is unable to provide the AC sealing plate accessory, contact SUN-GROW.

Note(3):Select AC cables that meet local standards and safety regulations based on the requirements listed in the table.

Note(4):For ease of installation, wires with a cross-section of 70-150mm² are recommended.

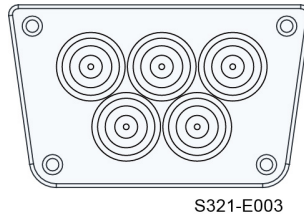

figure 5-3 Spare AC Sealing Plate



Inverters for Australia and New Zealand are equipped with the five-core sealing plate by default.

Inverters for Brazil are equipped with the three-core sealing plate by default, while the five-core sealing plate is included in the shipping accessories.

table 5-2 PE Wire Requirements

PE Wire Cross Sec- tion	Note
S/2 S: Phase wire cross-section	The specifications are valid only when the phase wire and PE wire use the same material. If otherwise, ensure that the cross section of the PE wire produces a conductance equivalent to that of the wire specified in the table.

Other sizes of grounding cables that meet local standards and safety regulations can also be used for grounding connections. But SUNGROW shall not be held liable for any damage caused.

5.4 Crimp OT/DT terminal

Crimp OT/DT terminal

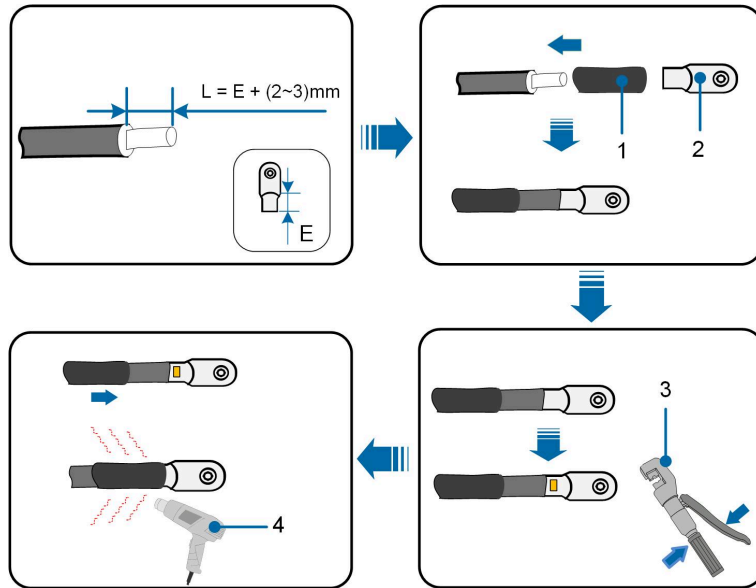

- 1. Heat shrink tubing
- 3. Hydraulic pliers

- 2. OT/DT terminal
- 4. Heat gun

Aluminum Cable Requirements

If an Aluminum cable is selected, use a copper to Aluminum adapter terminal to avoid direct contact between the copper bar and the Aluminum cable.

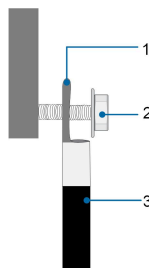

figure 5-4 Aluminum Cable Connection

- 1. Copper to Aluminum adapter terminal

- 2. Flange nut

- 3. Aluminum cable

NOTICE

Ensure that the selected terminal can directly contact with the copper bar. If there are any problems, contact the terminal manufacturer.

Ensure that the copper bar is not in direct contact with the aluminum wire. Otherwise, electrochemical corrosion may occur, impairing the reliability of electrical connection.

5.5 External Protective Grounding Connection

 DANGER

- There are large currents during the inverter's operation. If the inverter is powered on and put into operation without being grounded, it may lead to electric shock hazards or failures of major protective functions such as surge protection. Therefore, before powering on the inverter, make sure it has been reliably grounded; otherwise, damages caused therefrom will not be covered by warranty.
- When performing electrical connections of the inverter, give the highest priority to grounding. Be sure to carry out the grounding connection first.

 WARNING

- Since the inverter is not equipped with a transformer, neither the negative electrode nor the positive electrode of the PV string can be grounded. Otherwise, the inverter will not operate normally.
- Connect the grounding terminal to the external protective grounding point before AC cable connection, PV string connection, and communication cable connection.
- The external protective grounding point provides a reliable ground connection. Do not use an improper grounding conductor for grounding. Otherwise, it may cause product damage or personal injury.
- Depending on Local Rules, please also ground the PV panel subconstruction to the same common grounding point (PE Bar) in addition to local lightning protection rules.

⚠ WARNING

The external protective grounding terminal must meet at least one of the following requirements.

- The cross-sectional area of the grounding cable is not less than 10 mm² for copper wire or 16 mm² for aluminum wire. It is recommended that both the external protective grounding terminal and the AC side grounding terminal be reliably grounded.
- If the cross-sectional area of the grounding cable is less than 10 mm² for copper wire or 16 mm² for aluminum wire, ensure that both the external protective grounding terminal and the AC side grounding terminal are reliably grounded.

The grounding connection can be made by other means if they are in accordance with the local standards and regulations, and SUNGROW shall not be held liable for the possible consequences.

5.5.1 External Protective Grounding Requirements

All non-current carrying metal parts and device enclosures in the PV power system should be grounded, for example, brackets of PV modules and inverter enclosure.

When there is only one inverter in the PV system, connect the external protective grounding cable to a nearby grounding point.

When there are multiple inverters in the PV system, connect the external protective grounding terminals of all inverters and the grounding points of the PV module brackets to ensure equipotential connections to ground cables (according to the onsite conditions).

5.5.2 Connection Procedure

step 1 Prepare the cable and OT/DT terminal, refer to [Crimp OT/DT terminal](#).

step 2 Remove the screw on the grounding terminal and fasten the cable with a screwdriver.

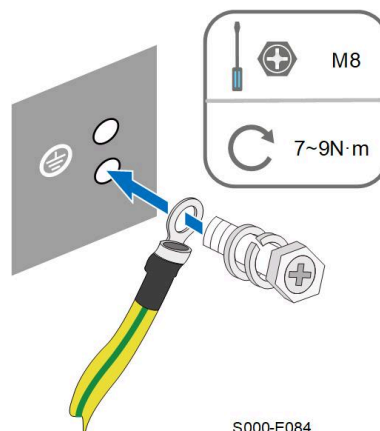

S000-E084

step 3 Apply paint to the grounding terminal to ensure corrosion resistance.



The grounding screws have been anchored to the side of the inverter before delivery, and do not need to be prepared. There are two grounding terminals. Use one of them to ground the inverter.

-- End

5.6 AC Cable Connection

5.6.1 AC Side Requirements



Only with the permission of the local grid department, the inverter can be connected to the grid.

Before connecting the inverter to the grid, ensure the grid voltage and frequency comply with requirements, for which, refer to "**Technical Data**". Otherwise, contact the electric power company for help.

AC Circuit Breaker

An independent circuit breaker or fuse should be installed on the output side of the inverter to ensure safe disconnection from the grid.

Inverter Model	Recommended Rated Voltage	Recommended Rated Current
SG125CX-P2	400V	250A
SG110CX-P2	400V	250A
SG75CX-P2	400V	160A

WARNING

AC circuit breakers should be installed on the output side of the inverter and the grid side to ensure safe disconnection from the grid.

- Determine whether an AC circuit breaker with greater overcurrent capacity is required based on actual conditions.
- Do not connect any local load between the inverter and the AC circuit breaker except for the tracking axis.
- Multiple inverters cannot share one AC circuit breaker.

Residual Current Monitoring Device

With an integrated universal current-sensitive residual current monitoring unit included, the inverter will disconnect immediately from the mains power once a fault current with a value exceeding the limit is detected.

However if an external residual current device (RCD) (type A is recommended) is mandatory, the switch must be triggered at the residual current. RCD of other specifications can also be used according to local standard. The recommended residual current is as follows.

Inverter	Recommended Residual Current
SG125CX-P2	1250 mA
SG110CX-P2	1100 mA
SG75CX-P2	750 mA

Multiple Inverters in Parallel Connection

If multiple inverters are connected in parallel to the grid, ensure that the total number of parallel inverters does not exceed 25. A maximum of 13 inverters can be connected in parallel if the PV module is equipped with optimizers. If SUNGROW Logger1000 is applied, please note that a maximum of 4900 optimizers or RSDs can be connected.

MV Transformer

The MV transformer used together with the inverter should meet the following requirements:

- A distribution transformer can be used if it is designed for the typical cyclical loads of a PV system (there is load in the day and no load at night).
- A liquid-immersed type transformer or a dry type transformer can be used, and the shield winding is not a requisite.
- The line-to-line voltage on the LV side of the transformer should endure the output voltage of inverter. When the transformer is connected to the IT grid, to-ground withstanding voltage of the LV winding of the transformer, the LV side AC cables, and the LV side secondary equipment (including the relay protection device, detection & measuring device, and other related auxiliary devices) should not be lower than 1,100V.
- The line-to-line voltage on the HV side of the transformer should comply with the local power grid voltage.
- A transformer with a tap changer on the HV side is recommended in order to keep the voltage consistent with the grid voltage.
- The voltage drop of system cable is no more than 3%.
- The DC component that the transformer can withstand is 1% of the fundamental current at rated power.
- For thermal rating, the load curve of the transformer and environment conditions should be taken into account.

- The apparent power of the inverter should never exceed the power of the transformer. The maximum AC current of all inverters connected in parallel must be taken into account. It is recommended that the total number of inverters that are connected to the grid not exceed 25.
- The transformer must be protected against overloading and short circuit.
- The transformer is an important part of grid-connected PV generation system. The fault tolerance capacity of the transformer should be taken into account at all times. The fault include: system short circuit, grounding fault, voltage drop, etc.
- Take ambient temperature, relative humidity, altitude, air quality, and other environmental conditions into account when selecting and installing the transformer.
- When the anti-PID function is enabled, observe the following items:
 - If the LV side winding is in Y shape, neutral point grounding is prohibited.
 - Surge protective devices (SPD) for the AC combiner box and on the LV side of the transformer are recommended to be connected in the "3+1" manner, as shown in the figure below. The Min. continuous operating voltages of M1-M4 are 690VAC.
 - The LV side winding of the transformer, AC cables, and secondary devices (including protective relay, detection and measurement instruments, and related auxiliary devices) must withstand the voltage to ground of at least 906 V.

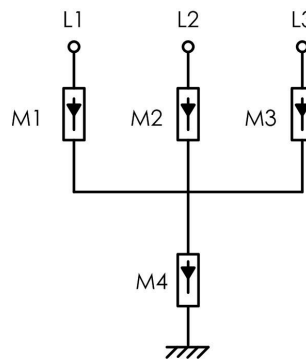

5.6.2 Requirements for OT/DT Terminal

OT/DT terminals (not included in the delivery scope) are required for fixing AC cables to the terminal block. Purchase the OT/DT terminals according to the following requirements.

OT/DT Terminals of Phase Wire

- Specification: M12

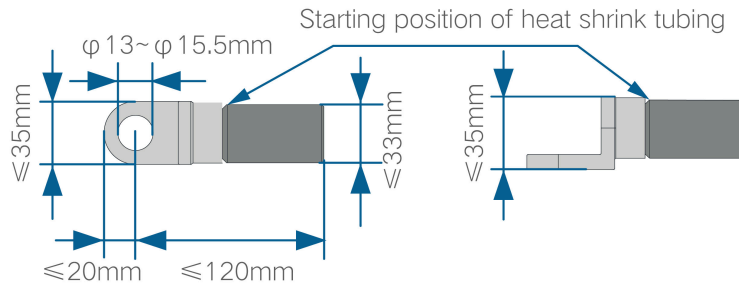

figure 5-5 Specifications of the Crimped OT/DT Terminal

OT/DT Terminal of PE Wire

- Specification: M12

5.6.3 Connection Procedure (For a Multi-core Cable)



In this manual, description is given by using five-core cable as an example. The wiring of the four-core cable is the same.

step 1 Disconnect the AC-side circuit breaker and prevent it from inadvertent reconnection.

step 2 Loosen two screws on the front cover of the junction box using the supplied hexagon socket wrench, and open the junction box. Keep the cover of the junction box open during wiring with a limit rod attached to the cover.

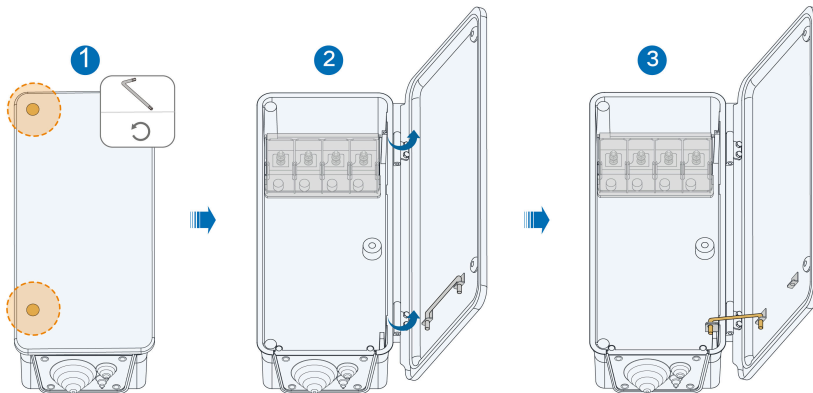

The screws on the front cover are captive screws. When the front cover is opened, the screws remain on it.

step 3 Loosen screws on the bottom sealing plate using the supplied hexagon socket wrench, and remove the sealing plate.

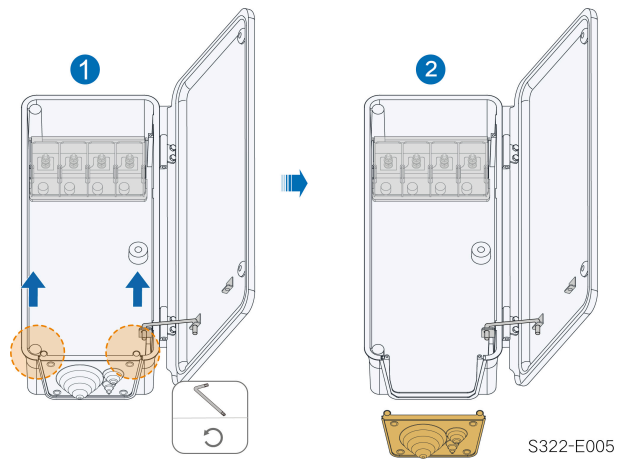

The screws on the sealing plate are captive screws. When the sealing plate is removed, the screws remain on it.

step 4 Cut off the excess part of sealing ring according to cable diameter.

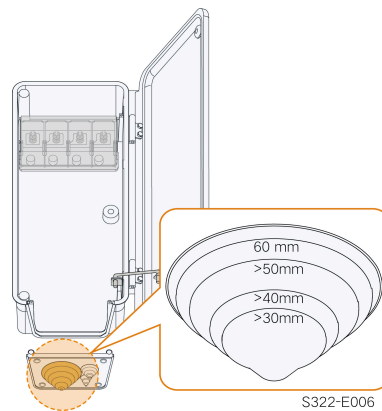

step 5 Lead the cable with the protective layer stripped through the sealing ring and secure screws on the bottom sealing plate.

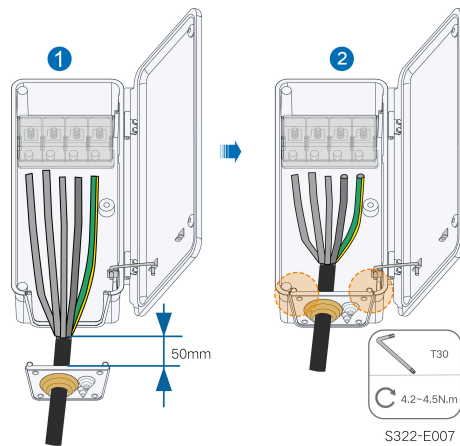

step 6 Open the protective cover.

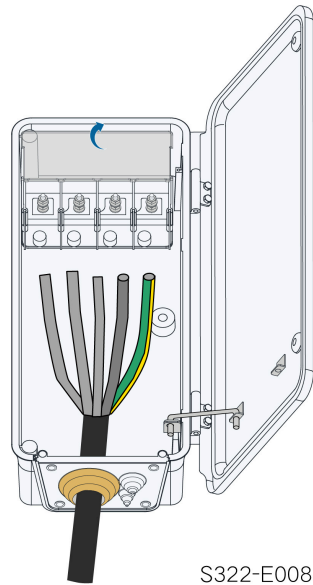

step 7 Connect cables with crimped OT/DT terminals to corresponding terminals and secure them. Please fasten AC terminals referring to the torque specified on the label inside the AC box.

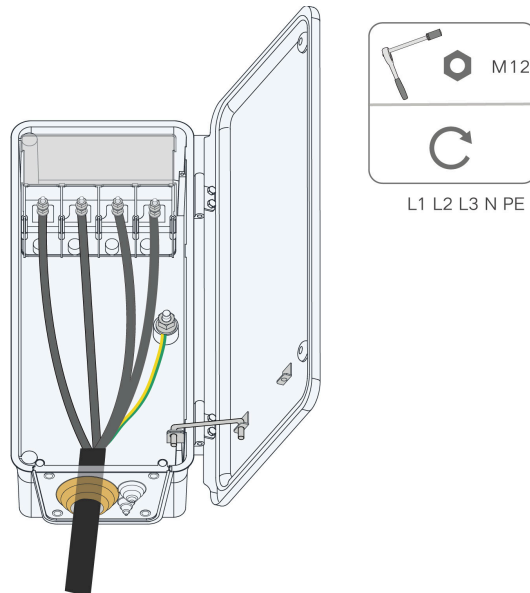
**NOTICE**

Note the terminal positions of PE wire and N wire. If a phase wire is connected to the PE terminal or N terminal, unrecoverable damage may be caused to the inverter.



Ensure that the depth L of the socket used is not less than 28mm.

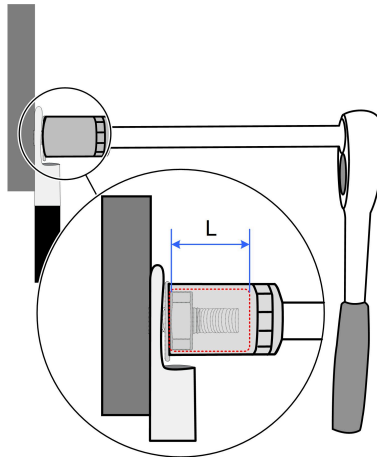

step 8 Close the protective cover.

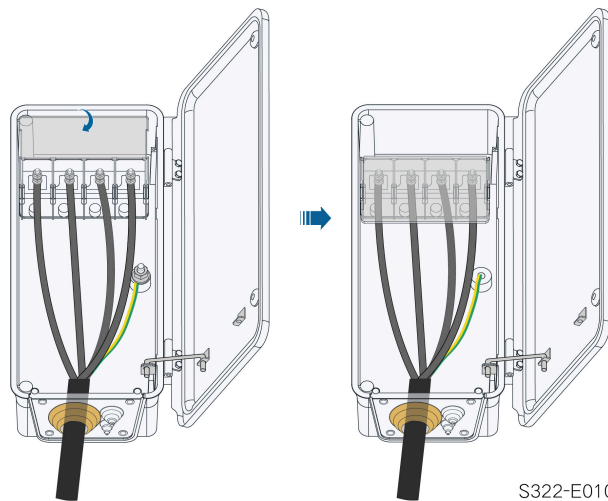

S322-E010

step 9 Remove the limit rod and put it back. Close the junction box and tighten the two screws on the front cover using the supplied hexagon socket wrench.

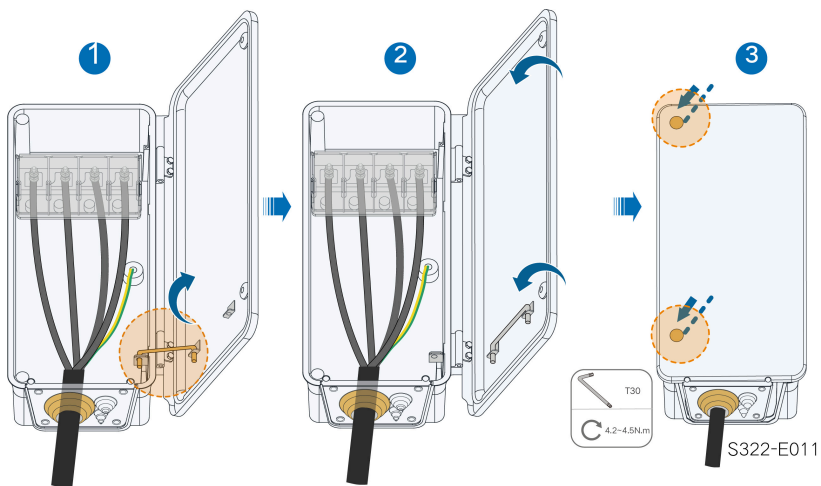

-- End

*If the PE cable is an independent single-core cable, it is inserted into the cabinet through the standby grounding terminal.

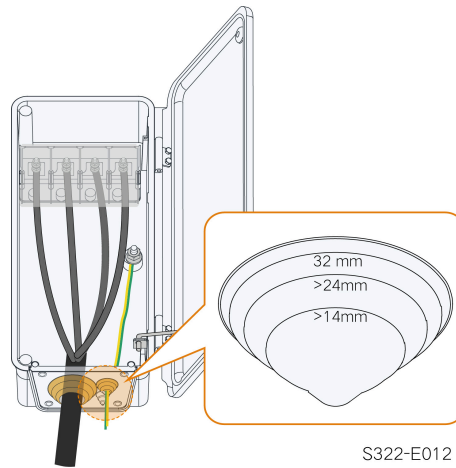

5.6.4 Connection Procedure (For Single-core Cables)

- step 1** Disconnect the AC-side circuit breaker and prevent it from inadvertent reconnection.
- step 2** Loosen two screws on the front cover of the junction box using the supplied hexagon socket wrench, and open the junction box. Keep the cover of the junction box open during wiring with a limit rod attached to the cover.

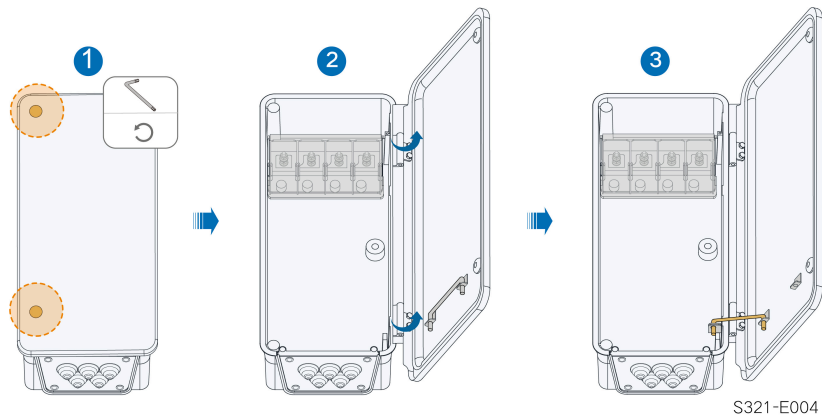

The screws on the front cover are captive screws. When the front cover is opened, the screws remain on it.

- step 3** Loosen screws on the bottom sealing plate using the supplied hexagon socket wrench, and remove the sealing plate.

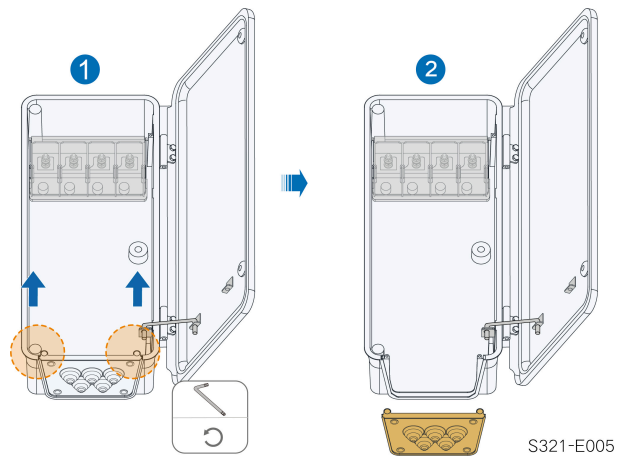

The screws on the sealing plate are captive screws. When the sealing plate is removed, the screws remain on it.

step 4 Cut off the excess part of sealing ring according to cable diameter.

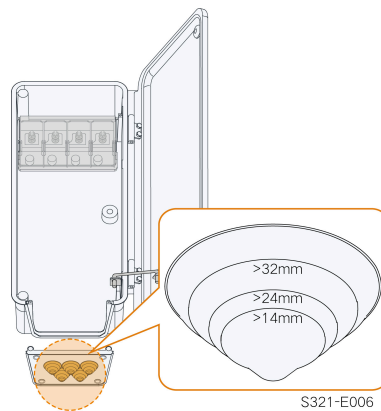

step 5 Lead the cable through the sealing ring and secure the screws on the bottom sealing plate.

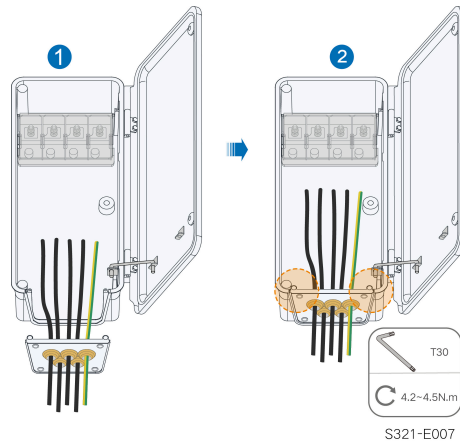

step 6 Open the protective cover.

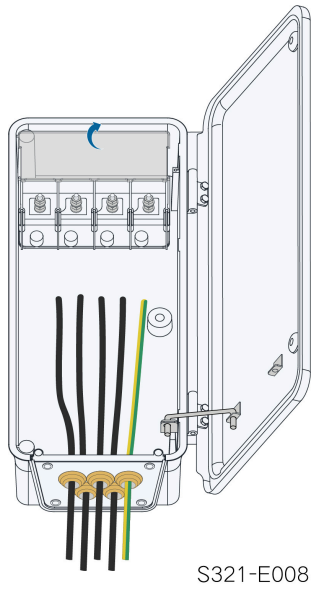

step 7 Connect cables with crimped OT/DT terminals to corresponding terminals and secure them. Please fasten AC terminals referring to the torque specified on the label inside the AC box.

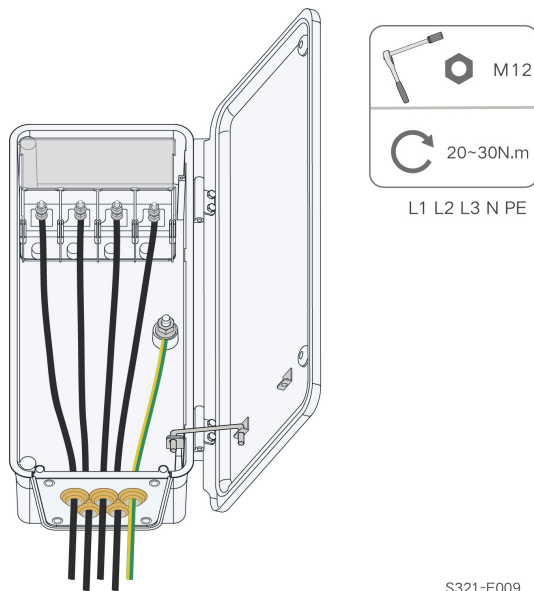

S321-E009

NOTICE

Note the terminal positions of PE wire and N wire. If a phase wire is connected to the PE terminal or N terminal, unrecoverable damage may be caused to the inverter.



Ensure that the depth L of the socket used is not less than 28 mm.

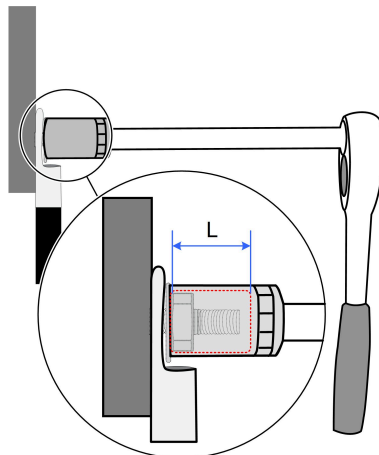

step 8 Close the protective cover.

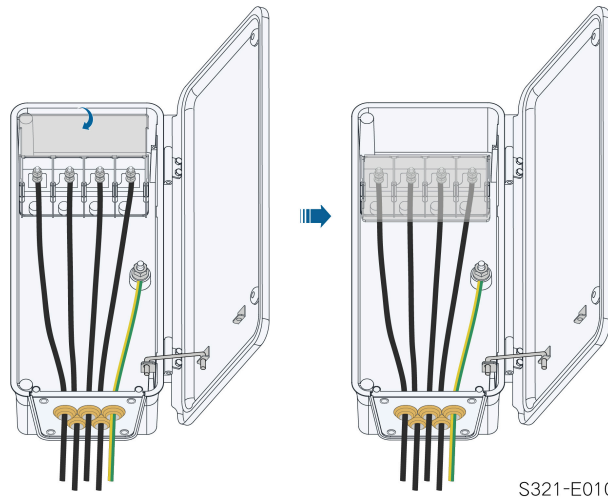

S321-E010

step 9 Remove the limit rod and put it back. Close the junction box and tighten the two screws on the front cover using the supplied hexagon socket wrench.

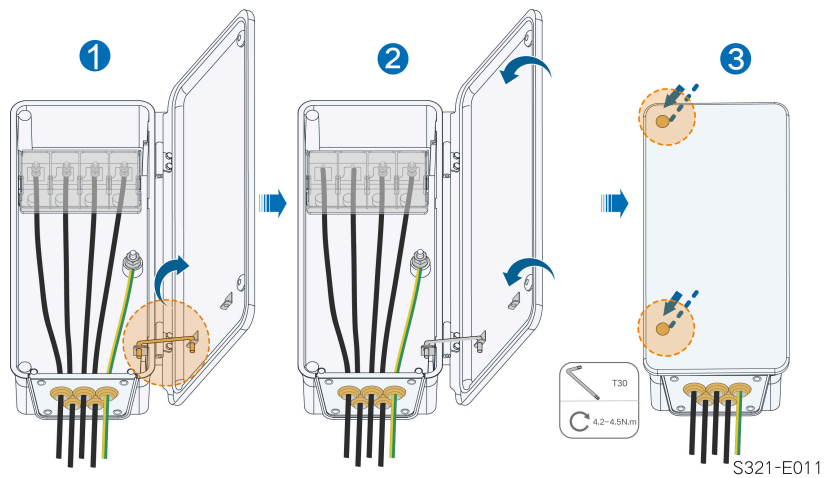

S321-E011

-- End

5.7 DC Cable Connection

⚠ DANGER

The PV string will generate lethal high voltage when exposed to sunlight.

- Respect all safety instructions listed in relevant documents about PV strings.

⚠ WARNING

- Make sure the PV array is well insulated to ground before connecting it to the inverter.
- Make sure the maximum DC voltage and the maximum short circuit current of any string never exceed inverter permitted values specified in "Technical Data".
- Check the positive and negative polarity of the PV strings, and connect the PV connectors to corresponding terminals only after ensuring polarity correctness.
- During the installation and operation of the inverter, please ensure that the positive or negative electrodes of PV strings do not short-circuit to the ground. Otherwise, an AC or DC short-circuit may occur, resulting in equipment damage. The damage caused by this is not covered by the warranty.
- Electric arc or contactor over-temperature may occur if the DC connectors are not firmly in place, and the loss caused is not covered by the warranty.
- If the DC input cables are reversely connected or the positive and negative terminals of different MPPT are shorted to ground at the same time, while the DC switch is in the "ON" position, do not operate immediately. Otherwise, the inverter may be damaged. Please turn the DC switch to "OFF" and remove the DC connector to adjust the polarity of the strings when the string current is lower than 0.5 A.
- Use the DC connectors supplied with the product for DC cable connection. Using incompatible DC connectors may result in serious consequences, and the device damage is not covered under warranty.
- Inverters do not support full parallel connection of strings (Full parallel connection refers to a connection method in that strings are connected in parallel and then connected to the inverter separately).
- Do not connect one PV string to multiple inverters. Otherwise, the inverters may be damaged.

NOTICE

The following requirements about PV string connection must be met. Otherwise, it may cause irreversible damage to the inverter, which is not covered by the warranty.

- Mixed use of PV modules of different brands or models in one MPPT circuit, or PV modules of different orientation or inclination in a string may not damage inverter, but will cause system bad performance!
- The inverter enters standby state when the input voltage ranges between 1,000 V and 1,100 V. The inverter returns to running state once the voltage returns to the MPPT operating voltage range, namely, 180 V to 1,000 V.

NOTICE

Note the following items when laying cables on site:

- The axial tension on PV connectors must not exceed 80 N. Avoid axial cable stress on the connector for a long time during field wiring.
- Radial stress or torque must not be generated on PV connectors. It may cause the connector waterproof failure and reduce connector reliability.
- Leave at least 50 mm of slack to avoid the external force generated by the cable bending affecting the waterproof performance.
- Refer to the specifications provided by the cable manufacturer for the minimum cable bending radius. If the required bending radius is less than 50 mm, reserve a bending radius of 50 mm. If the required bending radius is greater than 50 mm, reserve the required minimum bending radius during wiring.

5.7.1 PV Input Configuration

As shown in the figure below, the inverter is provided with multiple PV inputs, and each PV input is designed with an MPP tracker.

Each PV input operates independently and has its own MPPT. In this way, string structures of each PV input may differ from each other, including PV module type, number of PV modules in each string, angle of tilt, and installation orientation.

A maximum of two PV strings can be connected to an MPPT controller. For the best use of PV power, the type, quantity, tilt, and orientation of PV modules connected to the same MPPT shall be the same.

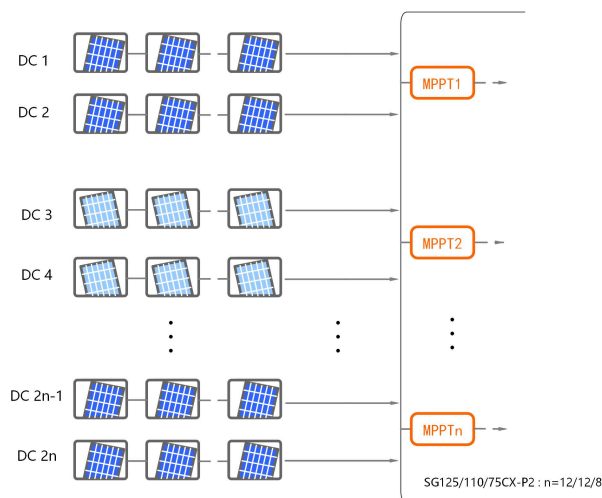



Prior to connecting the inverter to PV inputs, the specifications in the following table should be met:

Open Circuit Voltage Limit	Max. Current for Input Connector
1100 V	30A

Terminal Configuration Description

If the number of PV strings is 12 to 24, it is recommended to perform DC input wiring by referring to the table below.

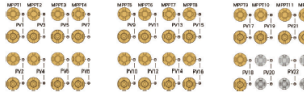
Num-ber of PV Strin-gs	DC PV Terminals	Num-ber of PV Strin-gs	DC PV Terminals
12	PV1, PV3, PV5, PV7, PV9, PV11, PV13, PV15, PV17, PV19, PV21, PV23 	13	PV1, PV2, PV3, PV5, PV7, PV9, PV11, PV13, PV15, PV17, PV19, PV21, PV23
14	PV1, PV2, PV3, PV4, PV5, PV7, PV9, PV11, PV13, PV15, PV17, PV19, PV21, PV23 	15	PV1, PV2, PV3, PV4, PV5, PV6, PV7, PV9, PV11, PV13, PV15, PV17, PV19, PV21, PV23
16	PV1, PV2, PV3, PV4, PV5, PV6, PV7, PV8, PV9, PV11, PV13, PV15, PV17, PV19, PV21, PV23 	17	PV1, PV2, PV3, PV4, PV5, PV6, PV7, PV8, PV9, PV10, PV11, PV13, PV15, PV17, PV19, PV21, PV23
18	PV1, PV2, PV3, PV4, PV5, PV6, PV7, PV8, PV9, PV10, PV11, PV12, PV13, PV15, PV17, PV19, PV21, PV23 	19	PV1, PV2, PV3, PV4, PV5, PV6, PV7, PV8, PV9, PV10, PV11, PV12, PV13, PV14, PV15, PV17, PV19, PV21, PV23

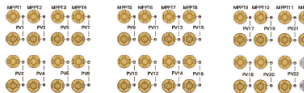
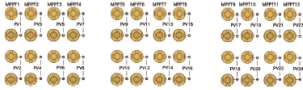
Number of PV Strings	DC PV Terminals	Number of PV Strings	DC PV Terminals
20	PV1, PV2, PV3, PV4, PV5, PV6, PV7, PV8, PV9, PV10, PV11, PV12, PV13, PV14, PV15, PV16, PV17, PV19, PV21, PV23 	21	PV1, PV2, PV3, PV4, PV5, PV6, PV7, PV8, PV9, PV10, PV11, PV12, PV13, PV14, PV15, PV16, PV17, PV18, PV19, PV21, PV23 
22	PV1, PV2, PV3, PV4, PV5, PV6, PV7, PV8, PV9, PV10, PV11, PV12, PV13, PV14, PV15, PV16, PV17, PV18, PV19, PV20, PV21, PV23 	23	PV1, PV2, PV3, PV4, PV5, PV6, PV7, PV8, PV9, PV10, PV11, PV12, PV13, PV14, PV15, PV16, PV17, PV18, PV19, PV20, PV21, PV22, PV23 
24	PV1, PV2, PV3, PV4, PV5, PV6, PV7, PV8, PV9, PV10, PV11, PV12, PV13, PV14, PV15, PV16, PV17, PV18, PV19, PV20, PV21, PV22, PV23, PV24 		

5.7.2 Assembling PV Connectors

⚠ DANGER

High voltage may be present in the inverter!

- Ensure all cables are voltage-free before performing electrical operations.
- Do not connect the AC circuit breaker before finishing electrical connection.

i SUNGROW provides corresponding PV connectors in the scope of delivery for quick connection of PV inputs. To ensure IP66 protection, use only the supplied connector or the connector with the same ingress of protection.

step 1 Strip the insulation from each DC cable by 8 mm ~ 10 mm.

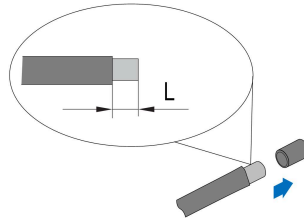

step 2 Assemble the cable ends with the crimping pliers.

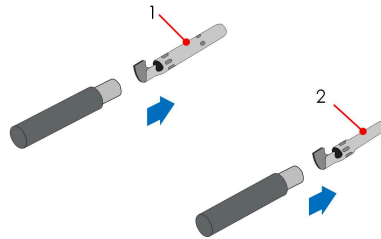

1: Positive crimp contact

2 : Negative crimp contact

step 3 Lead the cable through the cable gland, and insert the crimp contact into the insulator until it snaps into place. Gently pull the cable backward to ensure firm connection.

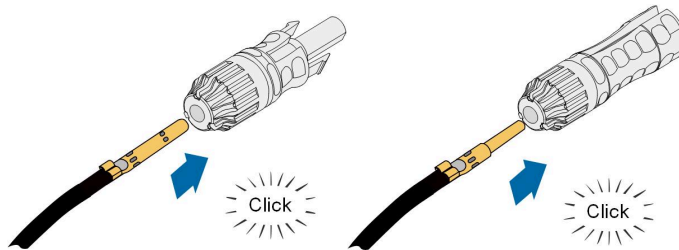

step 4 Tighten the cable gland and the insulator.

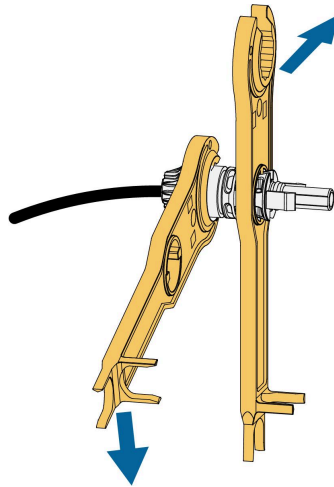

step 5 Check for polarity correctness.

NOTICE

If the PV polarity is reversed, the inverter will be in a fault or alarm state and will not operate normally.

-- End

5.7.3 Installing PV Connector

step 1 Ensure that the DC switch is in "OFF" position. Otherwise, manually turn it to "OFF".

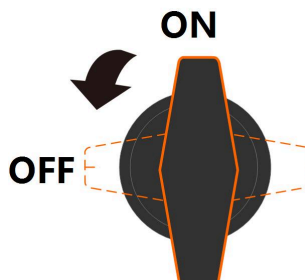

step 2 Check the cable connection of the PV string for polarity correctness and ensure that the open circuit voltage in any case does not exceed the inverter input limit of 1,100 V.

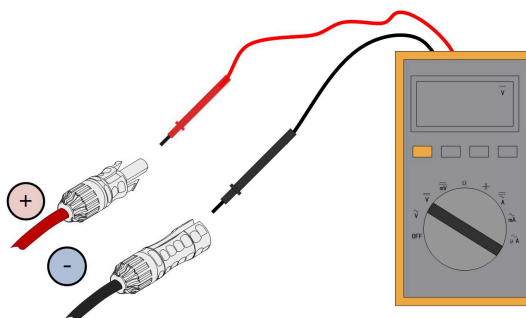
**NOTICE**

The multimeter must have a DC voltage range of at least 1100 V. If the voltage is a negative value, the DC input polarity is incorrect. Please correct the DC input polarity. If the voltage is greater than 1100 V, too many PV modules are configured to the same string. Please remove some PV modules.

step 3 If the inverter is configured with an optimizer, perform as follows. Otherwise, skip Step 4-7.

step 4 Connect the PV+ and PV- of the optimizer to the positive and negative terminals in the junction box of the PV module respectively.

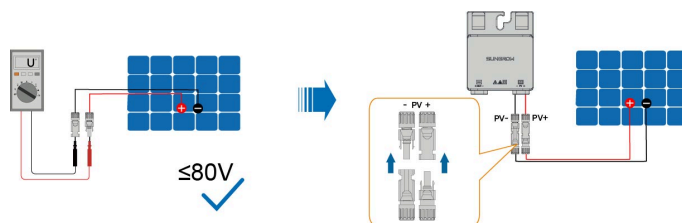
**NOTICE**

Do not connect the PV module to the OUT+ and OUT- of the optimizer. Otherwise, the optimizer or PV module will be damaged, and the loss is not covered by the warranty.

step 5 Connect the positive probe of a multimeter to OUT+ of the optimizer, and the negative probe of the multimeter to OUT- of the optimizer to check whether the optimizer is faulty. If the measured output voltage is 1 V, no fault occurs to the optimizer.

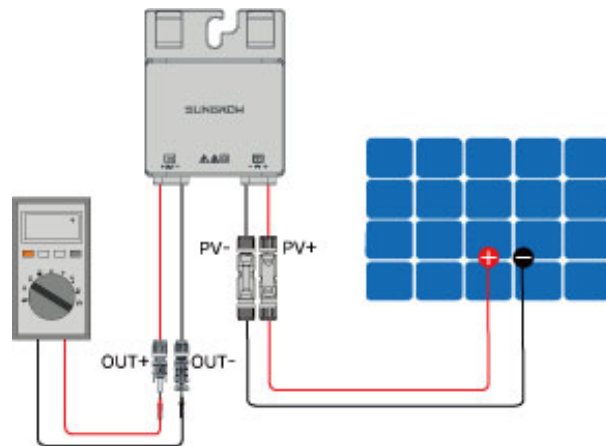

NOTICE

1. Use a multimeter to measure the output voltage of each optimizer after wiring.
2. Considering the effect of the accuracy of the multimeter on the actual measurement on site, the optimizer can function normally as long as the output voltage falls in the range of 0.9V - 1.1V.
3. If the output voltage is less than 0.9 V, check the following items:
 - Check whether the sunlight is sufficient.
 - Check whether the input side of the optimizer is connected to the PV module.
 - If the fault is not caused by foregoing reasons and still persists, please replace the optimizer.
4. If the output voltage is greater than 1.1 V, the optimizer fails. Please replace the optimizer.
5. If no voltage is detected, replace the optimizer or component.

step 6 When connecting multiple optimizers, connect OUT- of the first optimizer to OUT+ of the second optimizer, and so on. Use a multimeter to measure the optimizer voltage. If the measured output voltage is $1\text{ V} \times N$ (N is the number of optimizers), no fault occurs to the system.

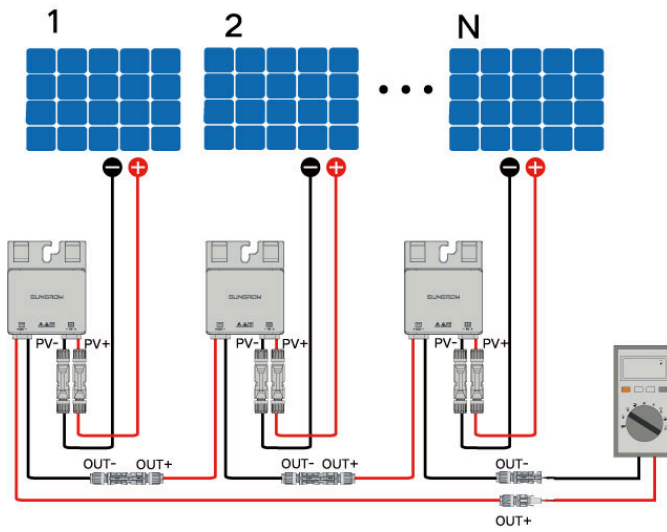

NOTICE

Whether connecting OUT+ of the first optimizer to OUT- of the second optimizer or connecting OUT- of the first optimizer to OUT+ of the second optimizer is dependent on the polarity of the extension cable that is connected to the inverter on site.

step 7 Connect OUT+ of the first optimizer and OUT- of the last optimizer to the PV input terminals of the inverter.

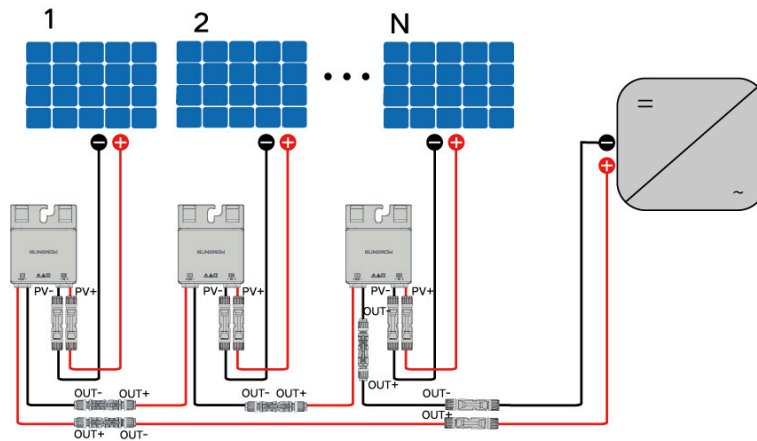

WARNING

If each PV module is equipped with an optimizer, the total power of PV modules in a PV input shall not exceed the maximum input power of a single PV input of the inverter.

Inverter	Number of Optimizers Supported in a String	Upper Limit of String Power(k-W)
SG125/110/75CX-P2	6~35	12

NOTICE

- **Branch-connector connection on the input side of the inverter is not supported by the optimizer.**
- **Please refer to the optimizer user manual for details.**

step 8 Connect the PV connectors to corresponding terminals until there is an audible click.

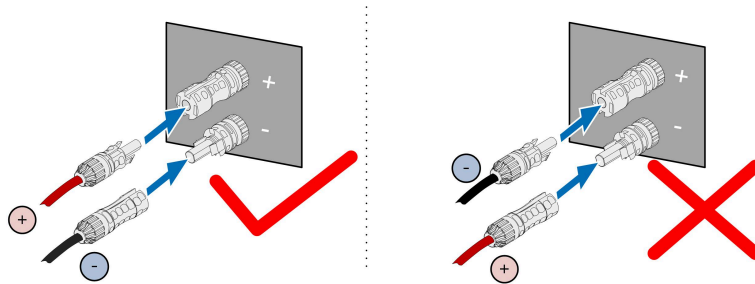

step 9 Follow the foregoing steps to connect PV connectors of other PV strings.

step 10 Seal any unused PV terminal with a terminal cap.

-- End

5.8 Wiring of Tracking System Power Cable (optional)

step 1 Please refer to step 1 and step 2 in [5.6.3 Connection Procedure \(For a Multi-core Cable\)](#).

step 2 Cut off the excess part of sealing ring according to cable diameter.



step 3 Lead the cable through the seal ring. The length of unstripped cable in the AC junction box is 50mm.

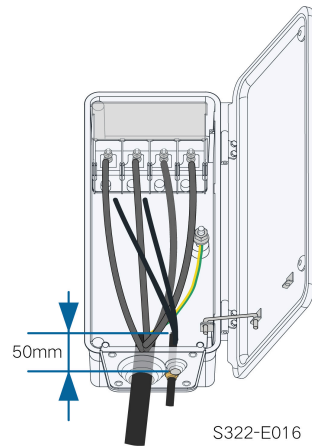

step 4 Place the OT terminals of power cable for tracking system on the OT/DT terminals of the AC cable, and secure them.

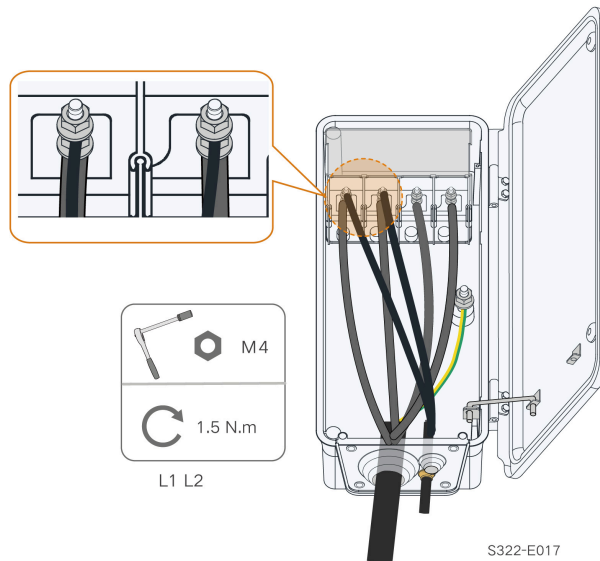

The power cables for tracking system can be connected to any two phases among L1, L2, and L3.

step 5 Close the protective cover. Close the junction box and tighten the two screws on the front cover using the supplied hexagon socket wrench.

-- End



The isolation switch ($\geq 400V$) and the fuse (16A, gM class) are needed between the inverter and tracking system control box for protection.
The length of the cable between the internal connection terminals of the inverter and the fuse is no more than 2.5m.

5.9 Wireless Communication Module Connection(optional)

Install the wireless communication module to the communication interface with a silk screen of COM3 at the bottom of the inverter.

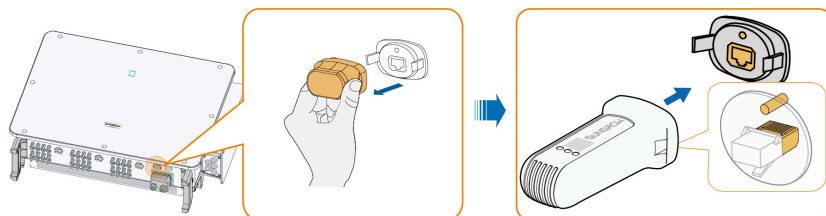

S321-E018

*The image shown here is for reference only. The actual product you receive may differ.

NOTICE

Once the communication module is in use, do not connect the inverter to a 3rd party data logger at the same time via RS485.



For details on module installation and configuration, refer to the manual delivered together with the module.

5.10 WiNet-S Connection (optional)

The WiNet-S / WiNet-S2 module supports Ethernet communication and WLAN communication. It is not recommended to use both communication methods at the same time.

For details, see the quick guide for the WiNet-S/WiNet-S2 module. Scan the following QR code for the quick guide.



WiNet-S



WiNet-S2



For the SG125CX-P2 inverter that has no compatible optimizer, WiNet can be used for communication

5.10.1 Ethernet Communication

step 1 (Optional) Strip the insulation layer of the communication cable with an Ethernet wire stripper, and lead the corresponding signal cables out. Insert the stripped communication cable into the RJ45 plug in the correct order, and crimp it with a crimper.

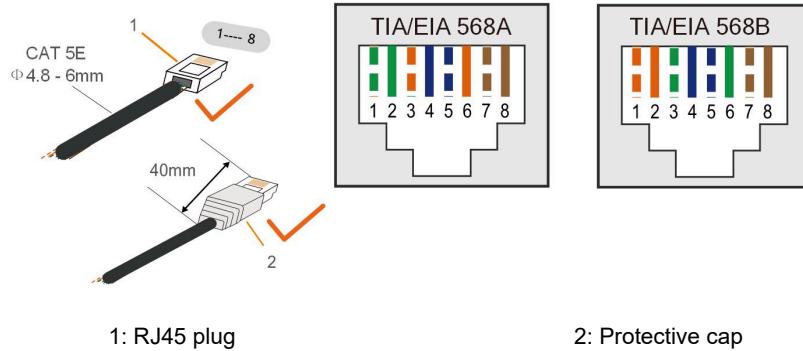

Skip this step if a standard network cable with RJ45 plug is prepared.

step 2 Unscrew the swivel nut from the communication module and take out the inner sealing ring.

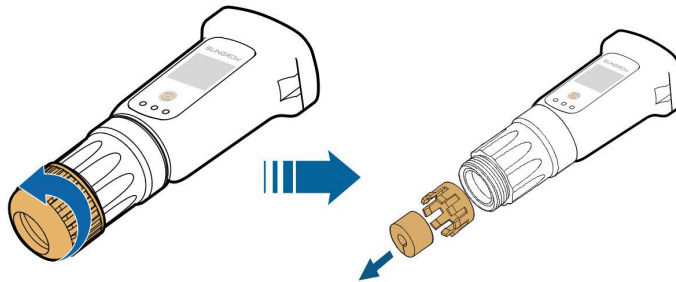

step 3 Unscrew the housing from the communication module.

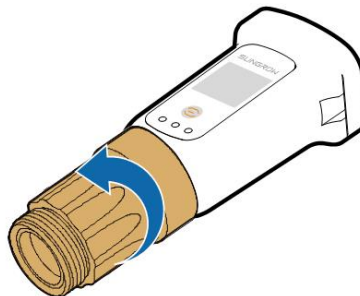

step 4 Thread the network cable through the swivel nut and gasket. Afterwards, route the cable into the opening of the sealing. Finally, insert the cable through the housing.

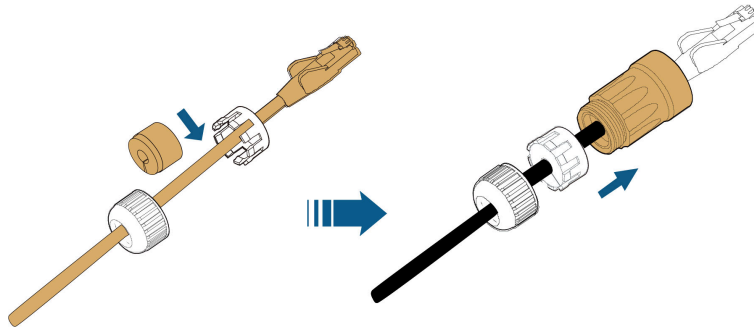

step 5 Insert the RJ45 plug into the front plug connector until there is an audible click and tighten the housing. Install the gasket and fasten the swivel nut.

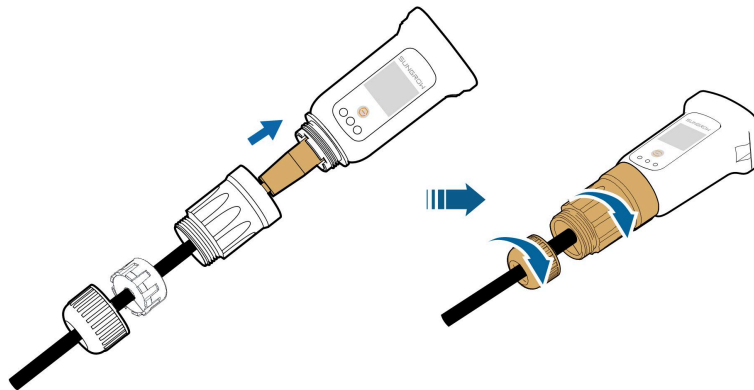

step 6 Remove the waterproof lid from the **COM3** terminal and install WiNet-S.

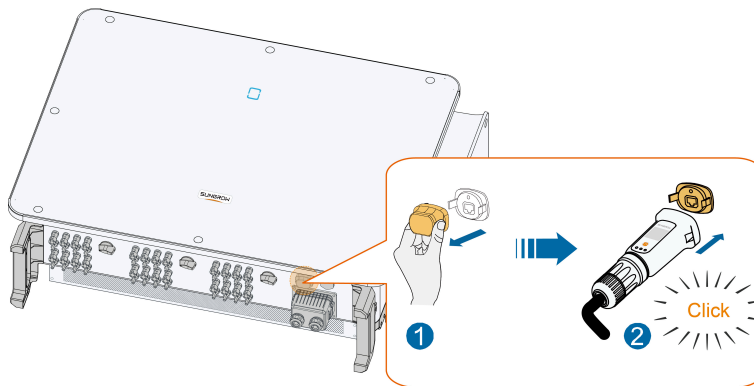

S321-E020

step 7 Slightly shake it by hand to determine whether it is installed firmly.

-- End

5.10.2 WLAN Communication

step 1 Remove the waterproof lid from the **COM3** terminal.

step 2 Install the module. Slightly shake it by hand to determine whether it is installed firmly, as shown below.

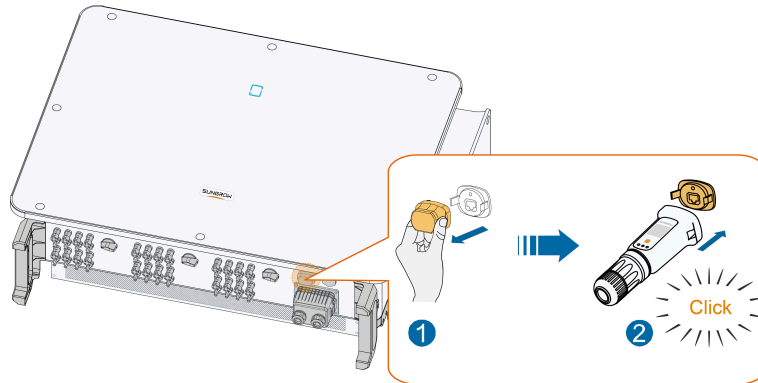

S321-E024

step 3 Refer to the guide delivered with the module for the set-up.

-- End

5.11 EyeS2 Connection (optional)

The EyeS2 module supports 2G communication .



For the SG125CX-P2 inverter that has a compatible optimizer, EyeS2 can be used for communication.

5.11.1 WLAN Communication

step 1 Remove the waterproof lid from the **COM3** terminal.

step 2 Install the module. Slightly shake it by hand to determine whether it is installed firmly, as shown below.

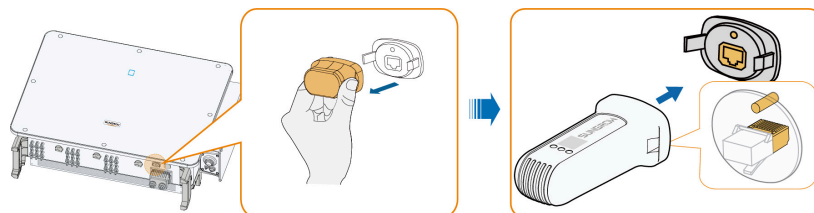

S322-E018

step 3 Refer to the guide delivered with the module for the set-up.

-- End

5.12 Communication Junction Box

Remove the Communication Junction Box

Squeeze both sides of the communication junction box with force, and pluck it out.

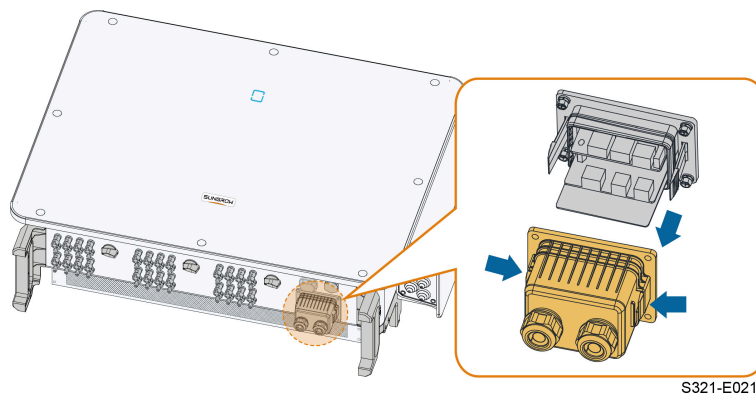

S321-E021

Install the Communication Junction Box

Put the junction box back and ensure a firm connection.

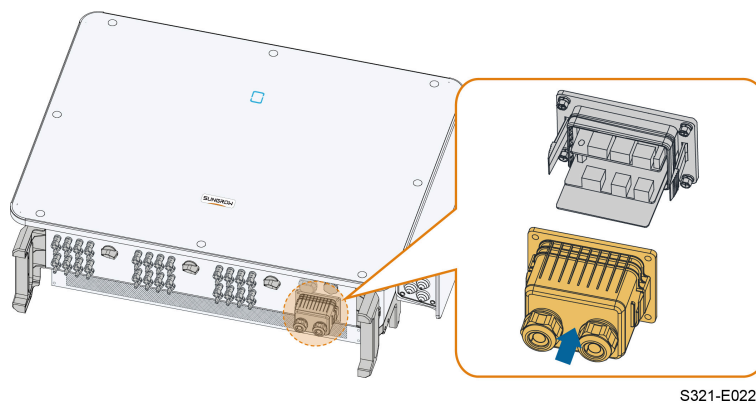

S321-E022

5.13 Communication Wiring Board

The inverter communication board consists of two layers, RS485 communication interface on the upper layer, and DI/DO interface on the lower layer.

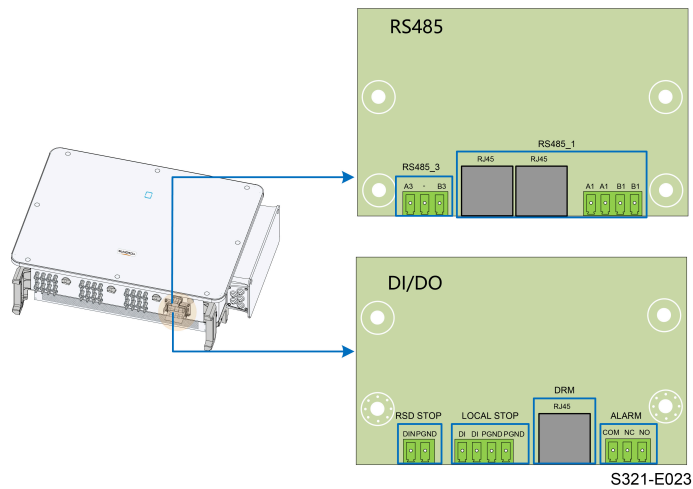
**table 5-3** Port description

No.	Silk Screen	Description
1	RS485_3	Used to connect the external meter*
2	RS485_1	Used to connect the external COM100E to realize data interaction with host computer or other monitoring devices Used for multiple inverters in the daisy chain to communicate
3	RSD STOP	Reserved
4	LOCAL STOP	Emergency stop
5	DRM	For external Demand Response Enabling Device ("AU"/ "NZ")
6	ALARM	Used to connect LED indicators or other devices to indicate whether the inverter is in the faulty state

5.14 RS485 Connection

5.14.1 Interface Description

The RS485 communication wiring board of the inverter is shown below.

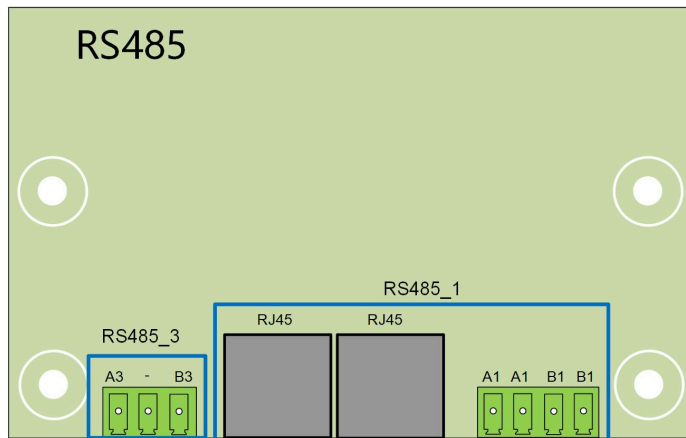

The following is the description of terminals.

table 5-4 RS485_1 interface (terminal block) description

No.	Description
A1	RS485A OUT , RS485A differential signal+
A1	RS485A IN , RS485A differential signal+
B1	RS485B OUT , RS485B differential signal-
B1	RS485B IN , RS485B differential signal-

table 5-5 RS485_1 interface (RJ45) description

No.	Description
PIN 1 ~ 2	N/A
PIN 3	RS485B differential signal-
PIN 4 ~ 5	N/A
PIN 6	RS485A differential signal+
PIN 7 ~ 8	N/A

table 5-6 RS485_3 terminal description

No.	Description
A3	RS485A differential signal+
B3	RS485B differential signal-

NOTICE

RJ45 and terminal block are two types of RS485_1 interface with same functions and different wiring methods. Choose one of the interfaces for wiring.

5.14.2 RS485 Communication System

Single-inverter Communication System

In case of a single inverter, communication connection requires only one RS485 communication cable.

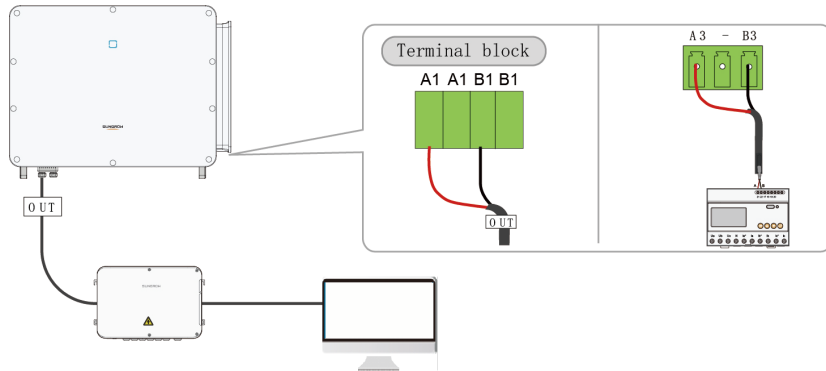

Multi-inverter Communication System

In case of multiple inverters, all the inverters in the daisy chain can be connected via RS485 cables for communication.

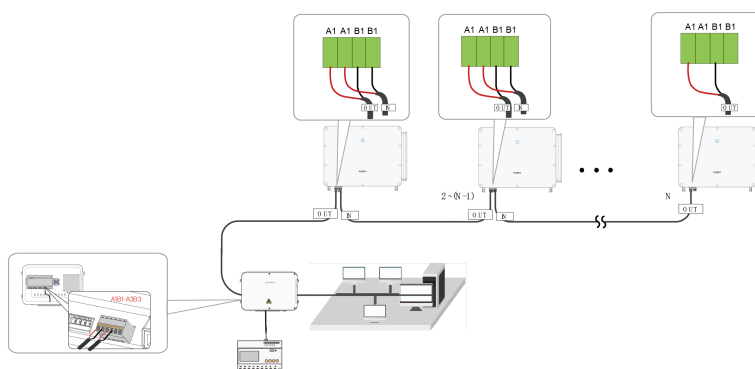

figure 5-6 Multi-inverter Communication System 【RS485_1 interface (terminal block)】

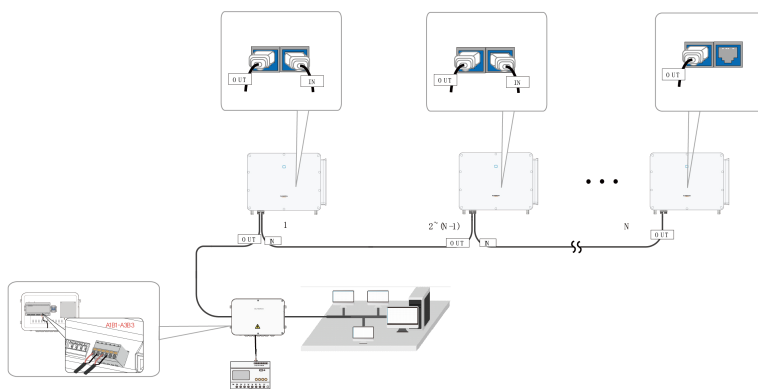

figure 5-7 Multi-inverter Communication System 【RS485_1 interface (RJ45)】



The length of an RS485 cable cannot exceed 1200m.

If multiple inverters communicate via the smart communication box, the number of permissible daisy chains and the number of devices allowed to be connected should meet the requirements (refer to the user manual of the smart communication box).

5.14.3 Connection Procedure(Terminal Block)

step 1 Remove the communication junction box, referring to [Remove the Communication Junction Box](#).

step 2 Unscrew the swivel nut of the junction box and select the sealing ring according to the cable diameter.

step 3 Strip off the protective layer and insulation layer of proper length.

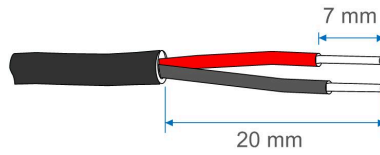

step 4 Lead the cable through the swivel nut, the sealing ring and the junction box in sequence.

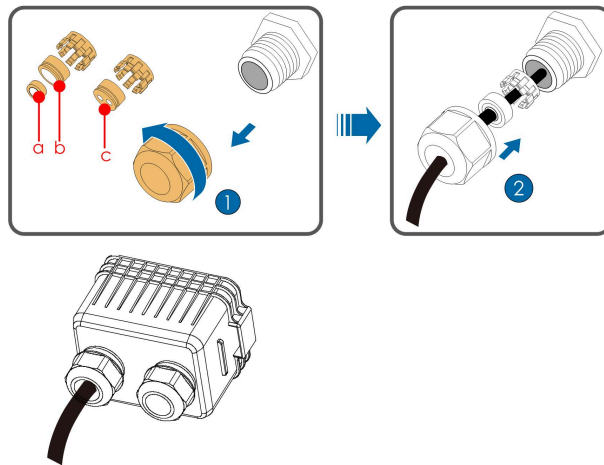

Outer Diameter D(mm)	Sealing Rings
4.5 ~ 6	c
6 ~12	a + b
12 ~ 18	b

step 5 Connect cables to the terminal socket.

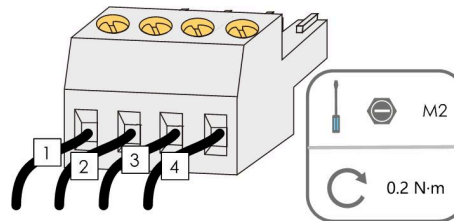

step 6 Insert the terminal socket into the corresponding terminal block.

table 5-7 Terminal description

No.	Description
1	RS485 A+
2	RS485 A+
3	RS485 B-
4	RS485 B-

step 7 If other cables should be connected to the communication circuit board, skip the subsequent steps and continue wiring. Otherwise, perform as follows.

step 8 Install the communication junction box, referring to [Install the Communication Junction Box](#).

step 9 Pull slightly the cable backward and screw the swivel nut clockwise.

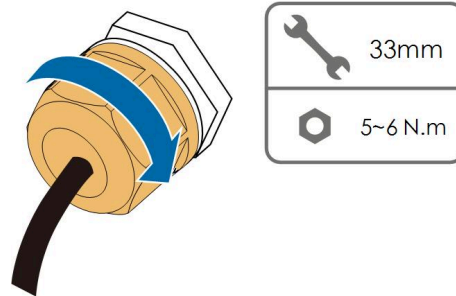

-- End

5.14.4 Connection Procedure (RJ45 Interface)

step 1 Remove the communication junction box, referring to [Remove the Communication Junction Box](#).

step 2 Unscrew the swivel nut of the junction box and select the sealing ring according to the cable diameter. Lead the cable through the swivel nut, the sealing ring and the junction box in sequence.

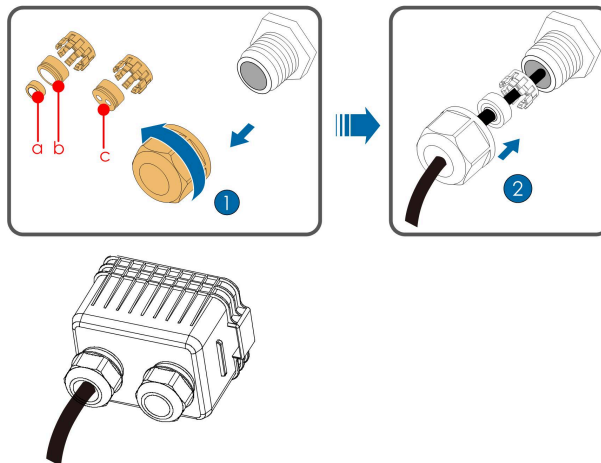

Outer Diameter D(mm)	Sealing Rings
4.5 ~ 6	c
6 ~ 12	a + b
12 ~ 18	b

step 3 Strip the insulation layer of the Ethernet cable with a stripper, lead out the signal wire, and insert it into the RJ45 connector (pins 3 and 6 are used for communication). Use the RJ45 crimping tool to crimp the RJ45 connector.

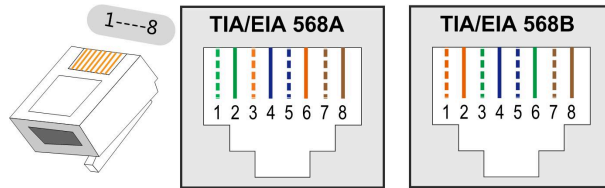

Pins 1 and 2 supply power to the SUNGROW communication module. Do not connect or use these two pins when making an RS485 communication cable. Otherwise, the inverter or other devices connected through the communication cable may be damaged.

step 4 Insert the RJ45 connector into the RJ45 jack.

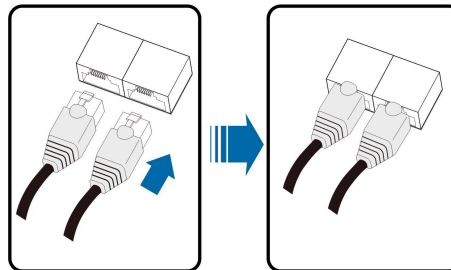

step 5 If other cables should be connected to the communication circuit board, skip the subsequent steps and continue wiring. Otherwise, perform as follows.

step 6 Install the communication junction box, referring to [Install the Communication Junction Box](#).

step 7 Pull slightly the cable backward and screw the swivel nut clockwise.

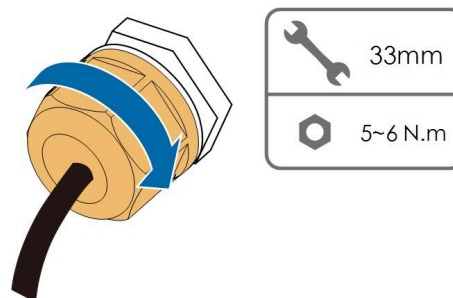

-- End

5.15 Dry Contact Connection

5.15.1 Dry Contact Function

The configuration circuit board is provided with fault output dry contact and emergency stop dry contact, as shown in the figure below.

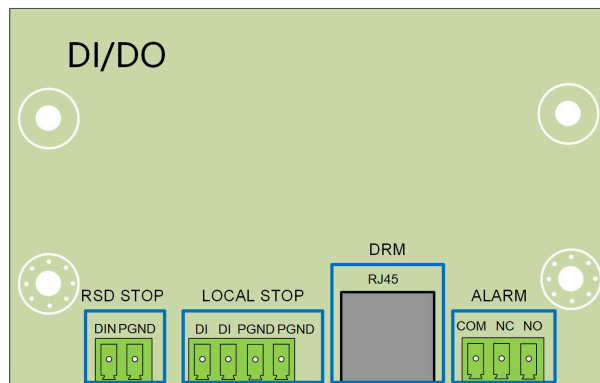

DO terminal (fault output dry contact)

The relay can be set to output fault alarms, and user can configure it to be a normally open contact (COM & NO) or a normally closed contact (COM & NC).

The relay is initially at the NC contact, and it will trip to another contact when a fault occurs. When alarm occurs, signal status change will not be triggered.

Use LED indicators or other equipment to indicate whether the inverter is in the faulty state.

The following Figures show the typical applications of normally open contact and normally closed contact:

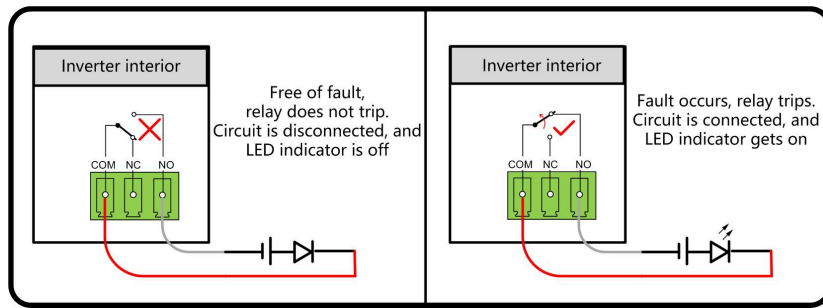

figure 5-8 Normally open contact

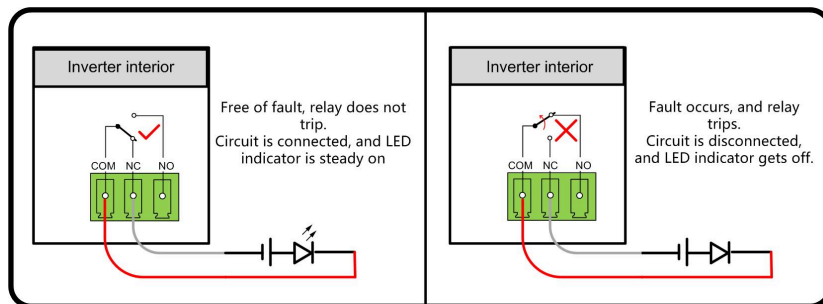

figure 5-9 Normally closed contact

Devices connected to the relay should comply with related requirements:

AC-Side Requirements	DC-Side Requirements
Max. voltage: 230 Vac	Max. voltage: 24 Vdc
Max. current: 3 A	Max. current: 3 A

DI terminal (emergency stop dry contact)

The dry contact can be configured to be an emergency stop contact.

When the DI contact and PGND contact are shorted by external controlled switch (The external switch can be configured as normally open contact or normally closed contact), the inverter will immediately shutdown.

NS Protection

NS Protection is used for German market currently. For a plant with an installed power over 30kW, an external NS Protection Relay is connected to inverters that are connected to each other with NS Protection terminals. When the grid runs abnormally, the status of the relay's dry contact changes, and the inverters are emergently shut down.

NS Protection(including Passive Valid) can be set. When NS Protection is enabled on the iSolarCloud, the inverters will operate normally when DI contact and PGND contact are shorted by external controlled switch, and the inverters will emergently stop when DI contact and PGND contact are disconnected.



The dry contacts only support passive switch signal input.

The following figure shows the typical application of local stop dry contact.

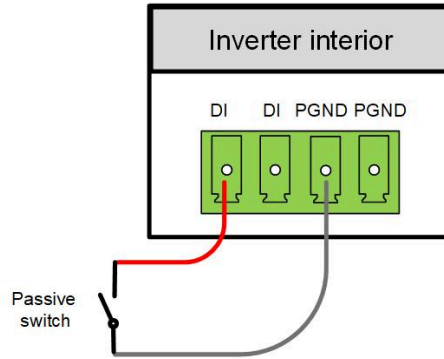

figure 5-10 Local stop contact

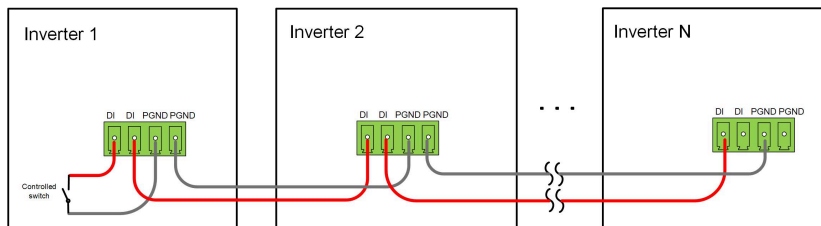

figure 5-11 Daisy chain topology

When wiring DI dry contacts, ensure that the maximum wiring distance meet the requirements in [10.2 Wiring Distance of DI Dry Contact](#).

5.15.2 Wiring Procedure



Connection method of the dry contacts is similar to that of the RS485 terminal block.

Refer to the wiring of terminal block described in chapter [5.14.3 Connection Procedure\(Terminal Block\)](#) to implement fault output, emergency shutdown and NS protection.

For NS protection(including passive valid), enable the function on iSolarCloud, refer to [7.8.2 Operation Parameters](#).

5.16 DRM Connection

5.16.1 DRM Function

DRM

The inverter supports the demand response modes as specified in the standard AS/NZS 4777. The inverter has integrated a terminal for connecting to a DRED. After the connection, the method of asserting DRMs as specified in the follow table.

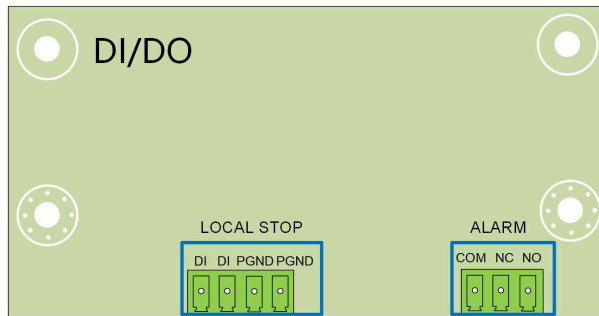

table 5-8 Method of Asserting DRMs

Mode	Method of Asserting
	Asserted by shorting pins 5 and 6
DRM0	Asserted when the impedance between pins 5 and 6 is detected to be above 20 k Ω



Enable the DRM function through the iSolarCloud App. If there are any problems, contact your distributor first. If the problem persists, contact SUNGROW. The DRM function is only applicable to devices for Australia and New Zealand.



Only DRM0 is supported by the inverter.

Ripple Control

In Germany, the grid company uses the Ripple Control Receiver to convert the grid dispatching signal and send it as a dry contact signal.

Wiring of the ripple control receiver dry contact cables is shown in the figure below:

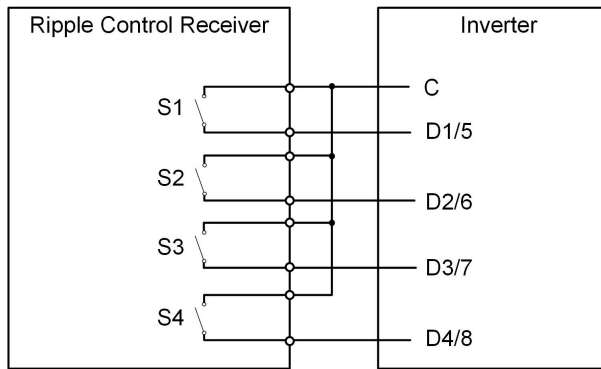

table 5-9 Method of Asserting DI Mode

S1	S2	S3	S4	Switch Operation on External RCR	Output power (in % of the Max. AC output power)
0	0	0	0	None	100%
1	0	0	0	Close S1	100%
0	1	0	0	Close S2	60%
0	0	1	0	Close S3	30%
1	1	0	0	Close S1 and S2	0% (disconnect from grid)

5.16.2 Connection Procedure

step 1 Remove the communication junction box, referring to [Remove the Communication Junction Box](#).

step 2 Unscrew the swivel nut of the junction box and select the sealing ring according to the cable diameter. Lead the cable through the swivel nut, the sealing ring and the junction box in sequence.

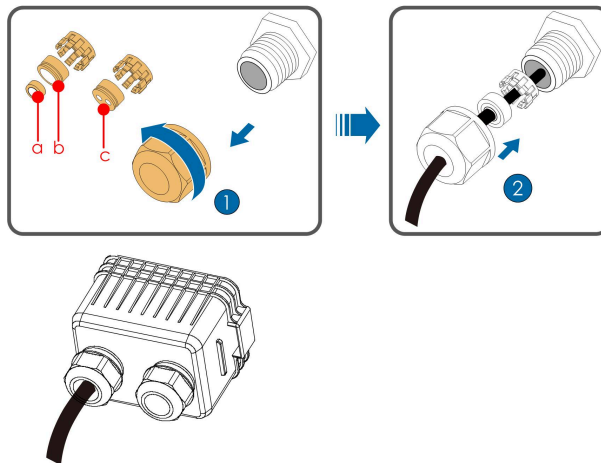

Outer Diameter D(mm)	Sealing Rings
4.5 ~ 6	c

Outer Diameter D(mm)	Sealing Rings
6 ~ 12	a + b
12 ~ 18	b

step 3 Strip the insulation layer of the Ethernet cable with a wire stripper, and insert the signal wires to the RJ45 connector. Crimp the RJ45 connector with a crimping tool.

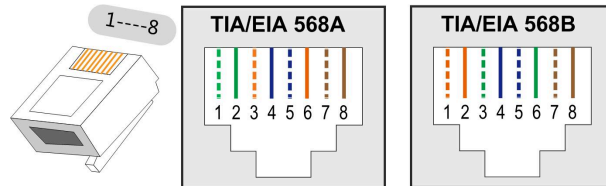

Pin	Assignment for inverters capable of both charging and discharging
1	DRM 1/5
2	DRM 2/6
3	DRM 3/7
4	DRM 4/8
5	RefGen
6	Com/DRM0
7	V+
8	V-

step 4 Insert the RJ45 connector to the RJ45 jack.

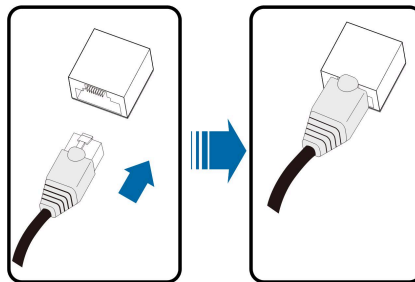

step 5 Install the communication junction box, referring to [Install the Communication Junction Box](#).

step 6 Pull slightly the cable backward and screw the swivel nut clockwise.

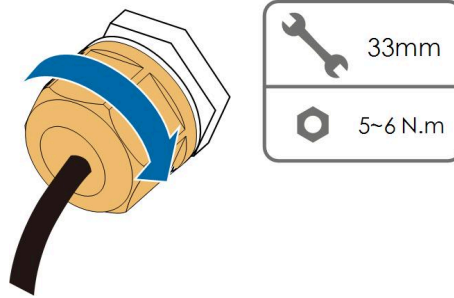

-- End

6 Commissioning

6.1 Inspection Before Commissioning

Check the following items before starting the inverter:

- All equipment has been reliably installed.
- DC switch(es) and AC circuit breaker are in the "OFF" position.
- The ground cable is properly and reliably connected.
- The AC cable is properly and reliably connected.
- The DC cable is properly and reliably connected.
- The communication cable is properly and reliably connected.
- The unused terminals are sealed.
- No foreign items, such as tools, are left on the top of the machine or in the junction box (if there is).
- The AC circuit breaker is selected in accordance with the requirements of this manual and local standards.
- All warning signs & labels are intact and legible.

6.2 Commissioning Procedure

If all of the items mentioned above meet the requirements, proceed as follows to start up the inverter for the first time.

- step 1** Rotate one DC switch of the inverter to the "ON" position. When the indicator blinks blue slowly, turn the other DC switches to the "ON" position.

NOTICE

- **Strictly follow the preceding sequence. Otherwise, the product may be damaged, and the loss caused is not covered by the warranty.**
- **If the DC side is powered up while the AC side is not, the inverter will report a fault named "Grid Power Outage" (the fault information can be viewed on the iSolarCloud App, see "Records" for details). The fault is automatically cleared when the AC circuit breaker between the inverter and the grid is closed.**
- **Before closing the AC circuit breaker between the inverter and the power grid, use a multimeter that is set to the AC gear to ensure that the AC voltage is within the specified range. Otherwise, the inverter may be damaged.**

- step 2** Close the AC circuit breaker between the inverter and the grid.
- step 3** Install the iSolarCloud App, see Installing App for details.
- step 4** Set initial protection parameters via the iSolarCloud App when the inverter is connected to the grid for the first time (see Step 4 in Login Procedure for details). If the irradiation and grid conditions meet requirements, the inverter normally operates.
- step 5** The home page is automatically displayed when the setting is completed. The indicator is steady blue, and the inverter is in grid-connected operation.

WARNING

It is strictly forbidden to close the DC switch if the inverter is in grid-connected status. Otherwise, the inverter may be damaged due to the lack of insulation impedance detection, and the loss caused is not covered by the warranty.

-- End

6.3 Optimizer Physical Layout (Optional)

- If PV modules are installed and optimizers are configured, check to ensure that all devices are reliably installed.
- Remove QR code labels from the optimizers and attach them to corresponding square cells on the physical layout.
- Please refer to the optimizer user manual for details of the optimizer physical layout.



In case the PV system, where the inverter is installed, is equipped with optimizers and the physical layout of optimizers has been successfully set, before removing the optimizers from the system or relocating the inverter to a PV system with no optimizers, please clear the physical layout of optimizers via iSolarCloud.

7 iSolarCloud App

7.1 Brief Introduction

The iSolarCloud App can establish communication connection to the inverter via the Bluetooth, thereby achieving near-end maintenance on the inverter. Users can use the App to view basic information, alarms, and events, set parameters, or download logs, etc.

*In case the communication module Eye, WiFi , WiNet-S or WiNet-S2 is available, the iSolar-Cloud App can also establish communication connection to the inverter via the mobile data or WiFi, thereby achieving remote maintenance on the inverter.



- This manual describes only how to achieve near-end maintenance via the Bluetooth connection. For remote maintenance through the Eye, WiFi, WiNet-S or WiNet-S2, refer to the related manuals in the delivery scope.
- Screenshots in this manual are based on the Android system V2.1.6 , and the actual interfaces may differ.

7.2 Installing App

Method 1

Download and install the App through the following application stores:

- MyApp (Android, mainland China users)
- Google Play (Android, users other than mainland China ones)
- App Store (iOS)

Method 2

Scan the following QR code to download and install the App according to the prompt information.



The App icon appears on the home screen after installation.



NOTICE

Systems equipped with SUNGROW optimizers can only work with SUNGROW communication devices and iSolarCloud App. Please use V2.1.6.20230411 or later versions of iSolarCloud App.

7.3 Login

7.3.1 Requirements

The following requirements should be met:

- The AC or DC side of the inverter is powered-on.
- The mobile phone is within 5 meters away from the inverter and there are no obstructions in between.
- The Bluetooth function of the mobile phone is enabled.



The inverter can only pair with one phone at a time through Bluetooth.

7.3.2 Login Procedure

step 1 Open the App to enter the login page, tap **Local Access** at the bottom of the page to go to the next page.

step 2 Establish the Bluetooth connection by either of the two following ways. If the LED indicator flashes blue, the connection is successfully established.

- Scan the QR code on the side of the inverter for Bluetooth connection.
- Tap "Manual connection" and select "Others" at the bottom of the page, the Bluetooth search page will automatically pop up, and select the inverter to be connected according to the SN on the nameplate on the side of the inverter body.

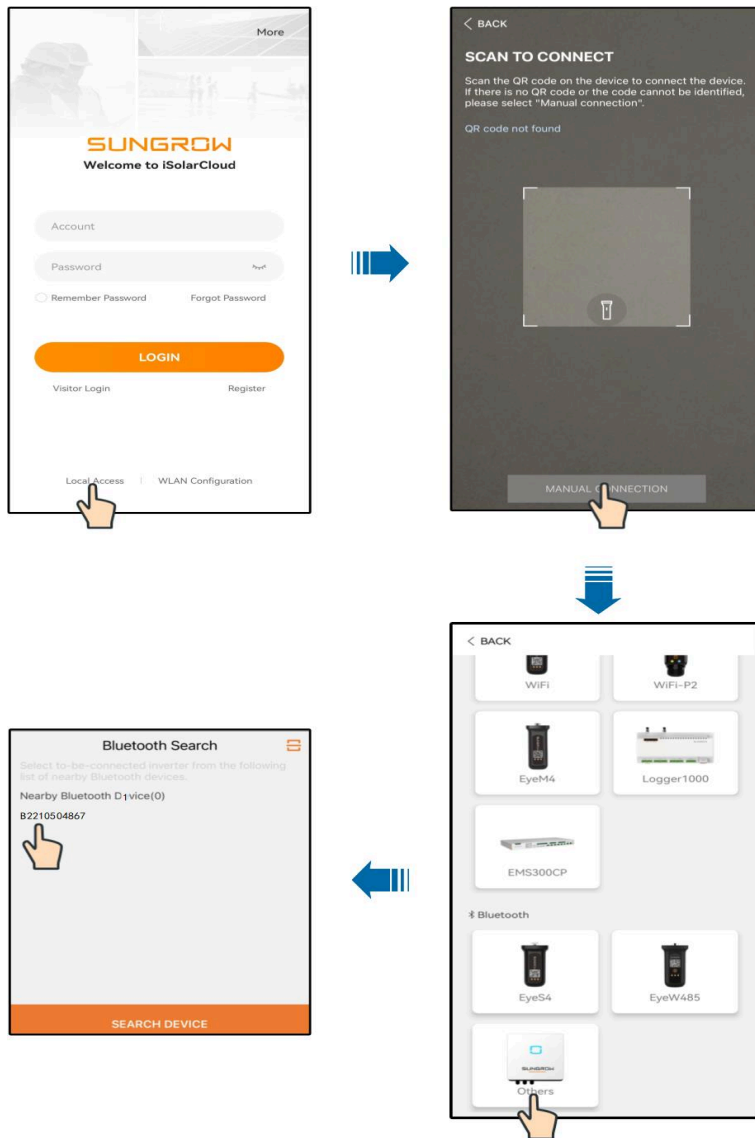

figure 7-1 Bluetooth Connection

NOTICE

If the inverter is configured with optimizers, log into iSolarCloud via WiNet-S2 or into the logger1000 Web to view and modify the parameters of the optimizer.

step 3 Enter the identity verification interface after the Bluetooth connection is established.

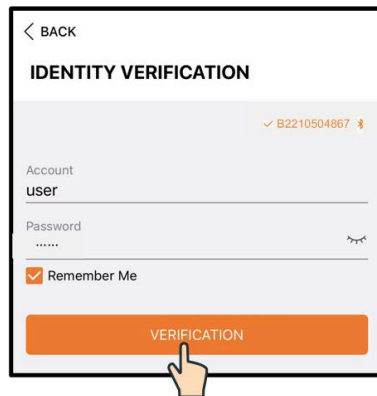

figure 7-2 Login



The Account is "user", and the initial password is "pw1111" or "111111" which should be changed for the consideration of account security. To set inverter parameters related to grid protection and grid support, contact your distributor to obtain the advanced account and corresponding password. If the distributor is unable to provide the required information, contact SUNGROW.

step 4 If the inverter is not initialized, you will enter the quick setting interface of initializing protection parameter.

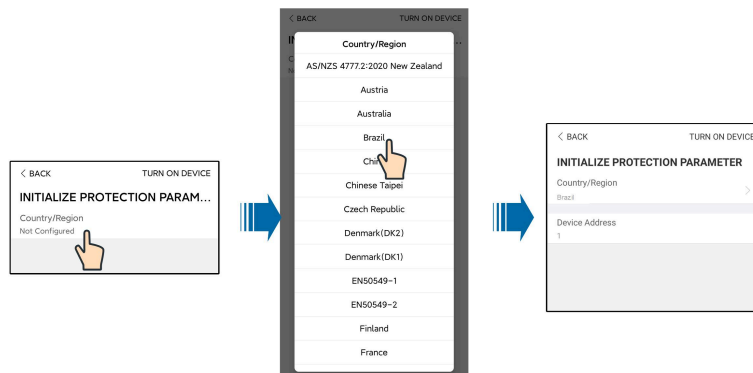

figure 7-3 Initialization Protection Parameter

NOTICE

The Country/Region must be set to the country where the inverter is installed. Otherwise, the inverter may report errors.

step 5 When the country is set to Australia, additionally set the applicable network service provider and then the grid type. Tap **Power Company** to select the correct power company.

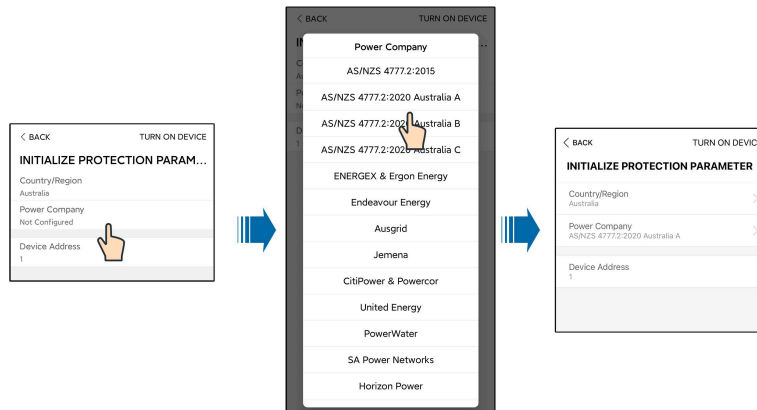

figure 7-4 Initialization Power Company

The image shown here is for reference only. Refer to the actual interface for the supported network service providers.

table 7-1 Power Company Information

Network Service Provider	Grid Type
AS/NZS 4777.2:2015	/
AS/NZS 4777.2:2020 Australia A	/
AS/NZS 4777.2:2020 Australia B	/
AS/NZS 4777.2:2020 Australia C	/
ENERGEX & Ergon Energy	<ul style="list-style-type: none"> • STNW1170: single phase < 10 kVA & three phase < 30 kVA • STNW1174 :30 kVA < PN ≤ 1500 kVA
Endeavour Energy	MDI 0043
Ausgrid	NS194
Jemena	<ul style="list-style-type: none"> • ≤ 10kVA per phase (or 30 kVA per three phase) • ELE GU 0014: 30-200kVA
CitiPower & Powercor	<ul style="list-style-type: none"> • ≤ 5 kVA for single-phase & 30 kVA for three-phase • > 30 kVA three-phase
United Energy	<ul style="list-style-type: none"> • UE-ST-2008.1: ≤ 10 kW for single-phase & 30 kW for three-phase • UE-ST-2008.2: > 30 kVA three-phase
PowerWater	Embedded Generation Notice Photovoltaic Systems:2020

Network Service Provider	Grid Type
SA Power Networks	<ul style="list-style-type: none"> • TS129-2019: < 10 kW for single-phase & 30 kW for three-phase • TS130-2017: > 30 kW & ≤ 200 kW • TS131-2018: > 200 kW
Horizon Power	<ul style="list-style-type: none"> • HPC-9DJ-13-0001-2019: ≤ 10 kVA for single-phase & 30 kVA for three-phase • HPC-9DJ-13-0002-2019: > 30 kVA & ≤1 MVA
westernpower	EDM # 33612889-2019
AusNet Services	Basic Micro Embedded Generation:2020

For compliance with AS/NZS 4777.2:2020, please select from Australia A/B/C. Please contact your electricity grid operator for which region to use.

step 6 After finishing the settings, tap **TUNR ON DEVICE** at the upper right corner and the device will be initialized. The App will send start instructions and the device will start and operate.

step 7 If the inverter is initialized, the App automatically turns to its home page.

- - End

7.4 Function Overview

The App provides parameter viewing and setting functions, as shown in the following figure.

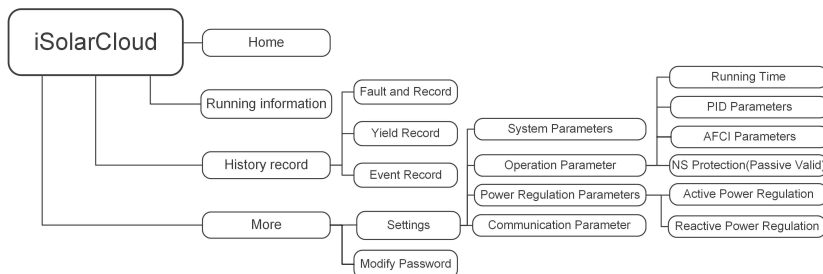

figure 7-5 App Function Tree Map

7.5 Home

After login, the home page is as follows:

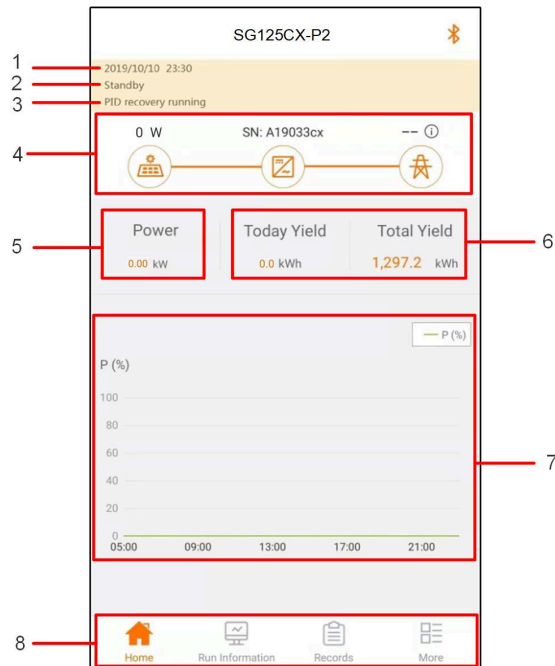

figure 7-6 Home Page

table 7-2 Home Page Description

No.	Designation	Description
1	Date and time	System date and time of the inverter.
2	Inverter state	Present operation state of the inverter. For details, refer to table 7-3 Description of Inverter State .
3	PID state	Present state of the PID. For details, refer to table 7-4 Description of PID State .
4	Power flow chart	Displays the PV power generation power, feed-in power, etc. The line with an arrow indicates energy flow between connected devices, and the arrow pointing indicates energy flow direction.
5	Real-time power	Output power of the inverter.
6	Power generation	Today power yield and accumulative power yield of the inverter.
7	Power curve	Shows the change of power between 5 am and 23 pm every day (Each point on the curve represents the percentage of present inverter power to rated power).
8	Navigation bar	Including Home , Run Information , Records , and More .

table 7-3 Description of Inverter State

State	Description
Run	After being energized, the inverter tracks the PV arrays' maximum power point (MPP) and converts the DC power into AC power. This is the normal operation mode.
Stop	The inverter is stopped.
Press to Shut Down	The inverter will stop operation by manually "stop" via App. In this way, inverter internal DSP stops. To restart the inverter, manually start via App.
Standby	Inverter enters standby mode when DC side input is insufficient. In this mode the inverter will wait within the standby duration.
Initial standby	The inverter is in the initial power-on standby state.
Starting Up	The inverter is initializing and synchronizing with the grid.
Warn Run	Warning information is detected.
Derating running	The inverter derates actively due to environmental factors such as temperature or altitude
Dispatch Running	The inverter runs according to the scheduling instructions received from the monitoring background
Fault	If a fault occurs, the inverter will automatically stop operation, and disconnect the AC relay. The fault information will be displayed in the app. Once the fault is removed in recovery time, the inverter will automatically resume running. When the country setup is German HV, which is complied with VDE-AR-4120, the inverter will not be automatically connected to the grid after the fault is cleared, and needs to wait for an external signal to trigger reconnection.

table 7-4 Description of PID State

State	Description
PID recovery running	The inverters perform PID recovery actively.
PID abnormality	It is detected that the ISO impedance is abnormal or the PID cannot work normally after the PID function is enabled.

If the inverter is running abnormally, the alarm or fault icon  will be displayed in the lower right corner of the inverter icon in power flow chart. The user can tap this icon to enter the alarm or fault interface to view detailed information and corrective measures.

7.6 Run Information

Tap **Run Information** on the navigation bar to enter the screen showing running information, slide the screen upwards to view all detailed information.

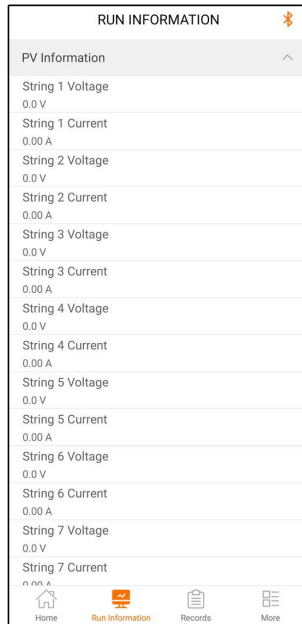

The run information includes the PV information, inverter information, input information, and output information.

7.7 Records

Tap **Records** on the navigation bar to enter the interface showing event records, as shown in the following figure.

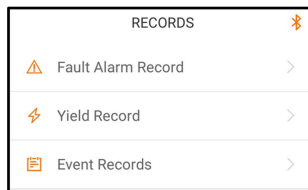

figure 7-7 Records

Fault Alarm Record

Tap **Fault Alarm Record** to enter the interface, as shown in the following figure.

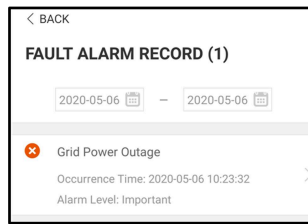



figure 7-8 Fault Alarm Record



Tap  to select a time segment and view corresponding records.
The inverter can record up to 400 latest entries.

Select one of the records in the list and tap the record to view the detailed fault information as shown in following figure.

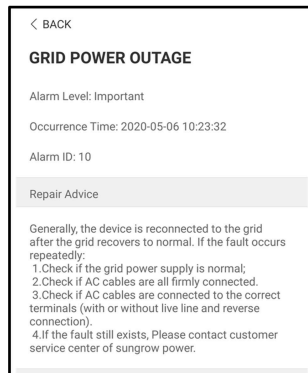

figure 7-9 Detailed Fault Alarm Information

Yield Record

Tap **Yield Record** to enter the interface showing daily power generation as shown in the following figure.

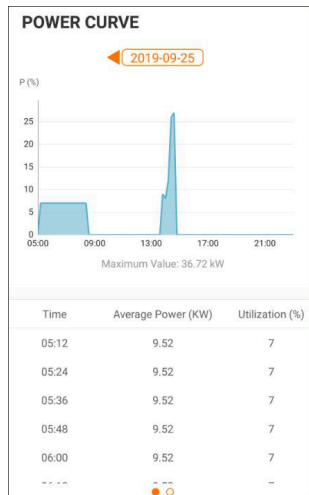

figure 7-10 Power Curve

The App displays power generation records in a variety of forms, including daily power generation graph, monthly power generation histogram, annual power generation histogram and total power generation histogram.

table 7-5 Yield Record Explanation

Parameter	Description
Power curve	Shows the power output from 5 am to 11 pm in a single day. Each point on the curve represents the percentage of present inverter power to rated power.
Daily yield histogram	Shows the power output every day in the present month.
Monthly yield histogram	Shows the power output every month in a year.
Annual yield histogram	Shows the power output every year.

Tap the time bar on the top of the interface to select a time segment and view the corresponding power curve.

Swipe left to check the power yields histogram.

Event Record

Tap **Event Record** to view event record list.



Click  to select a time segment and view corresponding records. The inverter can record up to 400 latest entries.

7.8 More

Tap **More** on the navigation bar to enter the corresponding interface, as shown in the following figure.

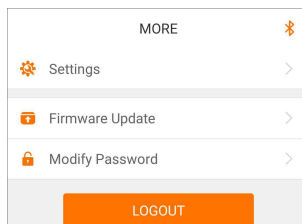

figure 7-11 More

7.8.1 System Parameters

Tap **Settings > System Parameters** to enter the corresponding interface, as shown in the following figure.

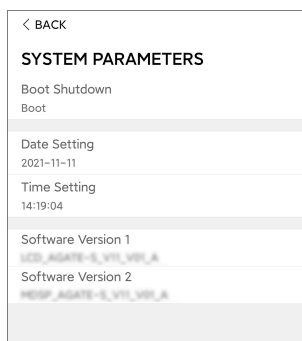

figure 7-12 System Parameters

* The image shown here is for reference only.

Boot/Shutdown

Tap **Boot/Shutdown** to send the boot/shutdown instruction to the inverter.

For Australia and New Zealand, when the DRM state is DRM0, the "Boot" option will be prohibited.

Date Setting/Time Setting

The correct system time is very important. Wrong system time will directly affect the data logging and power generation value. The clock is in 24-hour format.

Software Version

Version information of the current firmware.

7.8.2 Operation Parameters

Running Time

Tap **Settings > Operation Parameters > Running Time** to enter the corresponding interface.

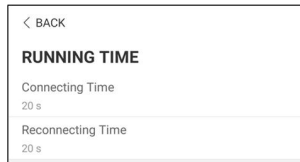

figure 7-13 Running Time

PID Parameters



The PID function may not be applicable in some areas. Please consult SUNGROW for details.

Tap **Settings > Operation Parameters > PID Parameters** to enter the corresponding interface.

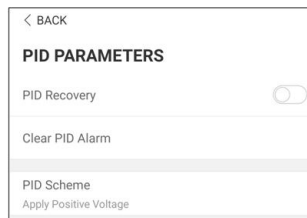

figure 7-14 PID Parameters

table 7-6 PID Parameter Description

Parameter	Description
PID Recovery	Enable/Disable the PID night recovery function. Once enabled, it works between 22:00 pm and 5:00 am by default.
Clear PID alarm	If ISO impedance abnormality or PID function exception is detected during running of the PID function, the inverter reports a PID abnormality and reminds the user to take corresponding measures. Clear the alarm report via this parameter once the problems are handled.
PID Scheme	Apply negative or positive voltage.



After the PID night recovery function is enabled, the fault indicator on the inverter front panel turns green.

AFCI Parameters



The AFCI function may not be applicable in some areas. Please consult SUNGROW for details.

Tap **Settings > Operation Parameters > AFCI Parameters** to enter the corresponding screen, on which you can set **AFCI Parameters**.

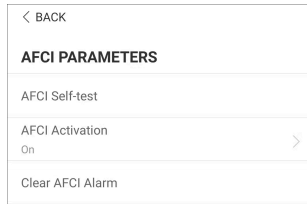

figure 7-15 AFCI Setting

NS Protection (Passive Valid)

Tap **Settings > Operation Parameters > Regular Parameters** to enter the corresponding screen, on which you can set the **NS Protection(Passive Valid)**.

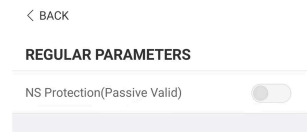

figure 7-16 NS Protection(Passive Valid)

7.8.3 Power Regulation Parameters

Active Power Regulation

Tap **Settings > Power Regulation Parameters > Active Power Regulation** to enter the screen, as shown in the following figure.

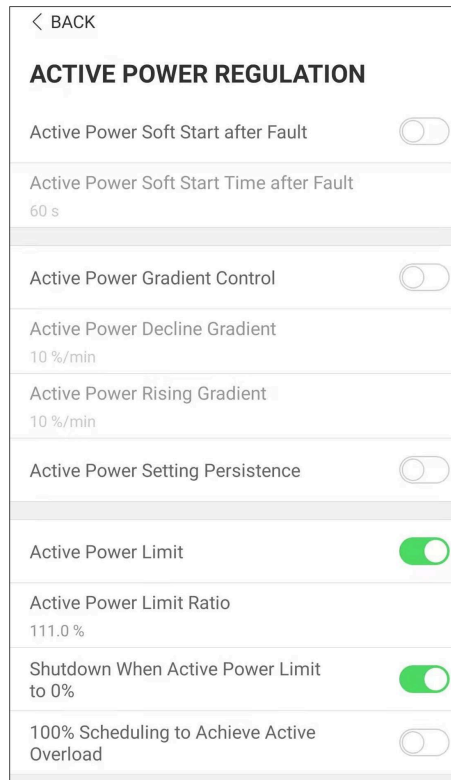

figure 7-17 Active Power Regulation

table 7-7 Active Power Regulation

Parameter	Definition/Setting Description	Range
Active power soft start after fault	The switch for enabling/disabling the soft start function after a fault occurs.	Enable/Disable
Active power soft start time after fault	Time that the soft start takes to raise the power from 0 to 100% rated power.	1s~1200s
Active power gradient control	Switch for enabling/disabling the active power rate settable function.	Enable/Disable
Active power decline gradient	The decline rate of inverter active power per minute.	3%/min~6000%/min
Active power rising gradient	The rise rate of inverter active power per minute.	3%/min~6000%/min

Parameter	Definition/Setting Description	Range
Active power setting persistence	Switch for enabling/disabling the function of saving output limited power.	Enable/Disable
Active power limit	The switch for limiting output power.	Enable/Disable
Active power limit ratio	The ratio of limiting output power to rated power in percentage.	0%~110%
Shutdown when active power limit to 0%	Switch used to determine whether the inverter is in stop state when the limited power reaches 0.	Enable/Disable
100% Scheduling to achieve active overload	Switch used to ensure that the inverter operates at the maximum active power when PV power limit ratio is set over 100%.	Enable/Disable

Reactive Power Regulation

Tap **Settings > Power Regulation Parameters > Reactive Power Regulation** to enter the screen, as shown in the following figure.

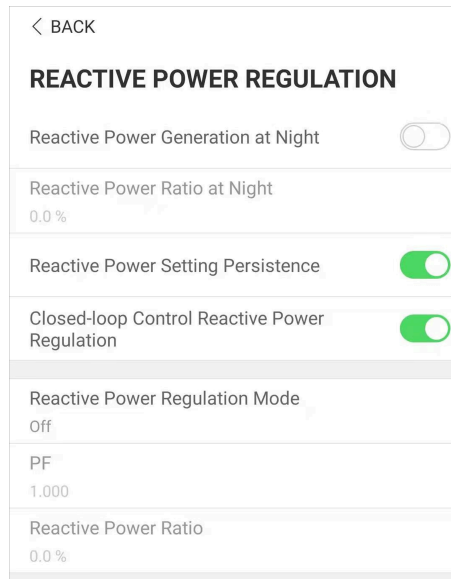

figure 7-18 Reactive Power Regulation

table 7-8 Reactive Power Regulation

Parameter	Definition/Setting Description	Range
Reactive power generation at night	Switch for enabling/disabling Q at night function.	Enable/Disable
Reactive power ratio at night	Reactive power ratio set for the Q at night function.	-100%~0%/0%~100%
Reactive power setting persistence	Switch for enabling/disabling the power-off function during reactive power	Enable/Disable
Closed-loop control reactive power regulation	Switch for closed-loop control during reactive power	Enable/Disable
Reactive power regulation mode	Reactive power regulation mode selection	Off/PF/Qt/Q(P)/Q(U)

The inverter provides the reactive power regulation function. Enable this function under **Reactive Power Regulation Mode** and select the appropriate mode.

table 7-9 Descriptions of reactive power regulation mode:

Mode	Descriptions
Off	The PF is fixed at +1.000.
PF	The reactive power can be regulated by the parameter PF (Power Factor).
Qt	The reactive power can be regulated by the parameter Q-Var limits (in %).

Mode	Descriptions
Q(P)	The PF changes with the output power of the inverter.
Q(U)	The reactive power changes with the grid voltage.

“Off” Mode

The reactive power regulation function is disabled. The PF is limited to +1.000.

“PF” Mode

The power factor is fixed and reactive power setpoint is calculated according to the current power. The PF ranges from 0.8 leading to 0.8 lagging.

Leading: The inverter supplies reactive power to the grid.

Lagging: The inverter absorbs reactive power from the grid.

“Qt” Mode

In the Qt mode, system rated reactive power is fixed, and the system injects reactive power according to the delivered reactive power ratio. The **Reactive Power Ratio** is set through the App.

The setting range of the reactive power ratio is 0~100% or 0~-100%, corresponding to the ranges of inductive and capacitive reactive power regulation respectively.

“Q(P)” Mode

The PF of the inverter output varies in response to the output power of the inverter.

table 7-10 “Q(P)” Mode Parameter Descriptions:

Parameter	Explanation	Range
Reactive response	re- Switch for enabling/disabling reactive response	Enable/Disable
Reactive response time	re- Completion time of reactive response	0.1s~600.0s
Q(P) Curve	Select corresponding curve according to local regulations	A, B, C*
QP_P1	Output power at P1 on the Q(P) mode curve (in percentage)	10% ~ 100%
QP_P2	Output power at P2 on the Q(P) mode curve (in percentage)	20% ~ 100%
QP_P3	Output power at P3 on the Q(P) mode curve (in percentage)	20% ~ 100%
QP_K1	Power factor at P1 on the Q(P) mode curve	Curve A/C: 0.8 ~ 1 Curve B: - 0.6 ~ 0.6
QP_K2	Power factor at P2 on the Q(P) mode curve	
QP_K3	Power factor at P3 on the Q(P) mode curve	
QP_EnterVoltage	Voltage percentage for Q(P) function activation	100% ~ 110%

Parameter	Explanation	Range
QP_ExitVoltage	Voltage percentage for Q(P) function deactivation	90% ~ 100%
QP_ExitPower	Power percentage for Q(P) function deactivation	1% ~ 100%
QP_EnableMode	Unconditional activation/deactivation of Q(P) function	Yes / No

* Curve C is reserved and consistent with Curve A currently.

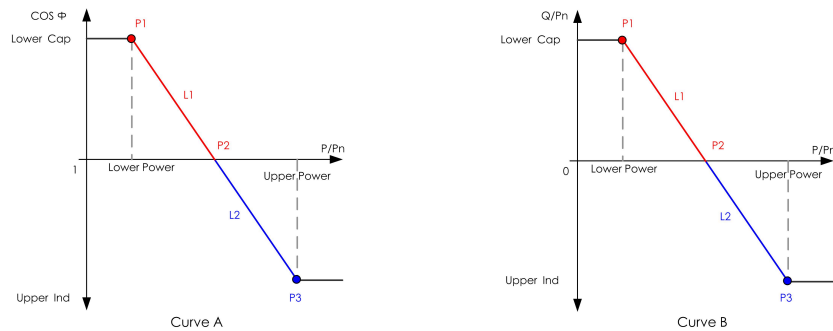

figure 7-19 Q(P) Curve

table 7-11 “Q(U)” Mode Parameter Descriptions:

Parameter	Explanation	Range
Reactive response	Switch for enabling/disabling reactive response	Enable/Disable
Reactive response time	Completion time of reactive response	0.1s~600.0s
Q(U) curve	Select corresponding curve according to local regulations	A, B, C*
Hysteresis Ratio	Voltage hysteresis ratio on the Q(U) mode curve	0 ~ 5%
QU_V1	Grid voltage limit at P1 on the Q(U) mode curve	80% ~ 100%
QU_Q1	Value of Q/Sn at P1 on the Q(U) mode curve	-60% ~ 0
QU_V2	Grid voltage limit at P2 on the Q(U) mode curve	80% ~ 100%
QU_Q2	Value of Q/Sn at P2 on the Q(U) mode curve	-60% ~ 60%
QU_V3	Grid voltage limit at P3 on the Q(U) mode curve	100% ~ 120%
QU_Q3	Value of Q/Sn at P3 on the Q(U) mode curve	-60% ~ 60%

Parameter	Explanation	Range
QU_V4	Grid voltage limit at P4 on the Q(U) mode curve	100% ~ 120%
QU_Q4	Value of Q/Sn at P4 on the Q(U) mode curve	0 ~ 60%
QU_EnterPower	Active power for Q(U) function activation	20% ~ 100%
QU_ExitPower	Active power for Q(U) function deactivation	1% ~ 20%
QU_EnableMode	Unconditional activation/deactivation of Q(U) function	Yes / No / Yes, Limited by PF
QU_Limited PF Value	PF value for Q(U) function activation	0~0.95

* Curve C is reserved and consistent with Curve A currently.

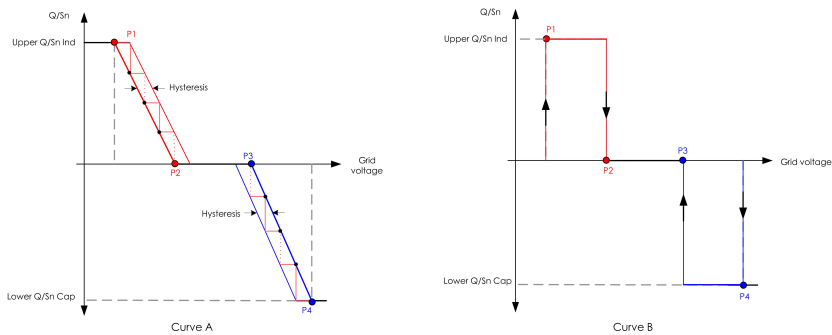

figure 7-20 Q(U) Curve

7.8.4 Communication Parameters

Serial Port Parameters

Tap **Settings > Communication Parameters > Serial Port Parameters** to enter the corresponding screen, as shown in the following figure. The device address ranges from 1 to 246.

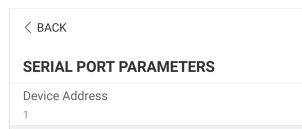



figure 7-21 Serial Port Parameters

7.8.5 Firmware Update

To avoid download failure due to poor on-site network signal, it is recommended to download the firmware package to the mobile device in advance.

Perform firmware update only during high irradiance conditions in order to prevent equipment failure.

- step 1** Enable the "Mobile data" of the mobile device.
- step 2** Open the App, enter the account and password on the login interface. Tap **Login** to enter the home interface.
- step 3** Tap **More > Firmware Download** to enter corresponding interface on which you can view the device list.
- step 4** Select the device model before downloading the firmware. Tap the device name in the device list to enter the firmware upgrade package detail interface, and tap  behind the firmware upgrade package to download it.



- step 5** Return to the **Firmware Download** interface, tap  in the upper right corner of the interface to view the downloaded firmware upgrade package.
- step 6** Login the App via local access mode. Refer to [7.3 Login](#).
- step 7** Tap **More** on the App home page and then tap **Firmware Update**.
- step 8** Tap the upgrade package file, a prompt box will pop up asking whether to upgrade the firmware with the file, tap **CONFIRM** to perform the firmware upgrade.

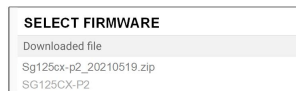

- step 9** Wait for the file to be uploaded. When the upgrade is finished, a message is displayed indicating that the upgrade is completed. Tap **Complete** to end the upgrade.

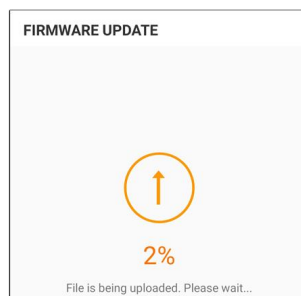

-- End

7.8.6 Grounding Detection



Contact your distributor to obtain the advanced account and corresponding password before setting the earth detection parameters. If the distributor is unable to provide the required information, contact SUNGROW.

Unauthorized personnel are not allowed to log in with this account. Otherwise, SUNGROW shall not be held liable for any damages caused.

Tap **More > Settings > Operation Parameters > Grounding Detection** to enter the corresponding screen.



figure 7-22 Grounding Detection

If the grounding detection is enabled, the DO relay will switch on automatically to signal the external alarm if the value exceeds the grounding detection alarm value.

The PV insulation resistance fault (fault sub-code 039) will trigger the DO relay to signal the external alarm.

7.8.7 Password Changing

Tap **Modify Password** to enter the modify password interface, as shown in the following figure.

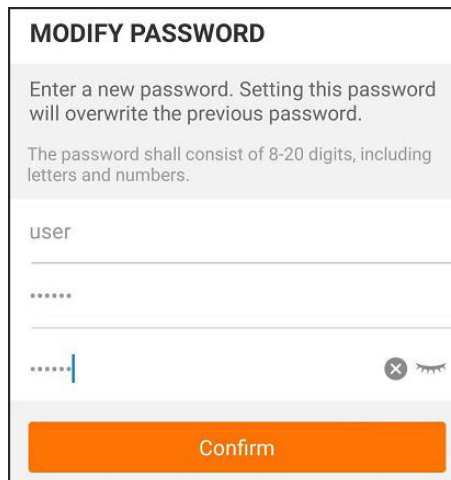

figure 7-23 Modify Password

The password shall consist of 8–20 digits, including letters and numbers.

8 System Decommissioning

8.1 Disconnecting the Inverter

CAUTION

Danger of burns!

Even if the inverter is shut down, it may still be hot and cause burns. Wear protective gloves before operating the inverter after it cools down.

For maintenance or other service work, the inverter must be switched off. Proceed as follows to disconnect the inverter. Lethal voltages or damage to the inverter will follow if otherwise.

step 1 Disconnect the external AC circuit breaker and prevent it from inadvertent reconnection.

step 2 Rotate the DC switch to the "OFF" position for disconnecting all of the PV string inputs.

step 3 Wait about 5 minutes until the capacitors inside the inverter completely discharge.

step 4 Ensure that the DC cable is current-free with a current clamp.

-- End

8.2 Dismantling the Inverter

CAUTION

Risk of burn injuries and electric shock!

After the inverter is powered off for 5 minutes, measure the voltage and current with professional instrument. Only when there is no voltage nor current can operators who wear protective equipment operate and maintain the inverter.



- Before dismantling the inverter, disconnect the inverter from both AC and DC power sources.
- If there are more than two layers of inverter DC terminals, dismantle the outer DC connectors before dismantling the inner ones.
- If the original packing materials are available, put the inverter inside them and then seal them using adhesive tape. If the original packing materials are not available, put the inverter inside a cardboard box suitable for the weight and size of this inverter and seal it properly.

step 1 Refer to [5 Electrical Connection](#) to disconnect all cables in reverse steps. In particular, when removing the DC connector, use a connector wrench to loosen the locking parts and install waterproof plugs.

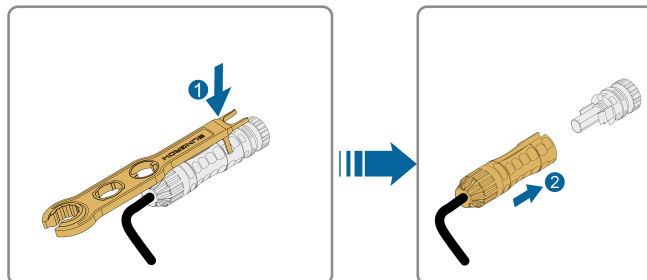

step 2 Refer to [4 Mechanical Mounting](#), to dismantle the inverter in reverse steps.

step 3 If necessary, remove the wall-mounting bracket from the wall.

step 4 If the inverter will be used again in the future, please refer to [3.2 Inverter Storage](#) for a proper conservation.

-- End

8.3 Disposal of Inverter

Users take the responsibility for the disposal of the inverter.

⚠ WARNING

Please scrap the inverter in accordance with relevant local regulations and standards to avoid property losses or casualties.

NOTICE

Some parts of the inverter may cause environmental pollution. Please dispose of them in accordance with the disposal regulations for electronic waste applicable at the installation site.

9 Troubleshooting and Maintenance

9.1 Troubleshooting

Once the inverter fails, the fault information is displayed on the App interface. If the inverter is equipped with an LCD screen, the fault information can be viewed on it.

The fault codes and troubleshooting methods of all PV inverters are detailed in the table below, and only some of the faults may occur to the model you purchased. When a fault occurs, you can check the fault information according to the fault code on the mobile app.

Fault Code	Fault Name	Corrective Measures
2, 3, 14, 15	Grid Overvoltage	<p>Generally, the inverter will be reconnected to the grid after the grid returns to normal. If the fault occurs repeatedly:</p> <ol style="list-style-type: none">1. Measure the actual grid voltage, and contact the local electric power company for solutions if the grid voltage is higher than the set value.2. Check whether the protection parameters are appropriately set via the App or the LCD. Modify the overvoltage protection values with the consent of the local electric power operator.3. Contact Sungrow Customer Service if the preceding causes are ruled out and the fault persists.
4, 5	Grid Undervoltage	<p>Generally, the inverter will be reconnected to the grid after the grid returns to normal. If the fault occurs repeatedly:</p> <ol style="list-style-type: none">1. Measure the actual grid voltage, and contact the local electric power company for solutions if the grid voltage is lower than the set value.2. Check whether the protection parameters are appropriately set via the App or the LCD.3. Check whether the AC cable is firmly in place.4. Contact Sungrow Customer Service if the preceding causes are ruled out and the fault persists.

Fault Code	Fault Name	Corrective Measures
8	Grid Overfrequency	Generally, the inverter will be reconnected to the grid after the grid returns to normal. If the fault occurs repeatedly:
9	Grid Underfrequency	<ol style="list-style-type: none"> 1. Measure the actual grid frequency, and contact the local electric power company for solutions if the grid frequency is beyond the set range. 2. Check whether the protection parameters are appropriately set via the App or the LCD. 3. Contact Sungrow Customer Service if the preceding causes are ruled out and the fault persists.
10	Grid Power Outage	<p>Generally, the inverter will be reconnected to the grid after the grid returns to normal. If the fault occurs repeatedly:</p> <ol style="list-style-type: none"> 1. Check whether the grid supplies power reliably. 2. Check whether the AC cable is firmly in place. 3. Check whether the AC cable is connected to the correct terminal (whether the live wire and the N wire are correctly in place). 4. Check whether the AC circuit breaker is connected. 5. Contact Sungrow Customer Service if the preceding causes are ruled out and the fault persists.
12	Excess Current Leakage	<ol style="list-style-type: none"> 1. The fault can be caused by poor sunlight or damp environment, and generally the inverter will be reconnected to the grid after the environment is improved. 2. If the environment is normal, check whether the AC and DC cables are well insulated. 3. Contact Sungrow Customer Service if the preceding causes are ruled out and the fault persists.
13	Grid Abnormal	<p>Generally, the inverter will be reconnected to the grid after the grid returns to normal. If the fault occurs repeatedly:</p> <ol style="list-style-type: none"> 1. Measure the actual grid, and contact the local electric power company for solutions if the grid parameter exceeds the set range. 2. Contact Sungrow Customer Service if the preceding causes are ruled out and the fault persists.

Fault Code	Fault Name	Corrective Measures
17	Grid Voltage Imbalance	<p>Generally, the inverter will be reconnected to the grid after the grid returns to normal. If the fault occurs repeatedly:</p> <ol style="list-style-type: none"> 1. Measure the actual grid voltage. If grid phase voltages differ greatly, contact the electric power company for solutions. 2. If the voltage difference between phases is within the permissible range of the local power company, modify the grid voltage imbalance parameter through the App or the LCD. 3. Contact Sungrow Customer Service if the preceding causes are ruled out and the fault persists.
28, 29, 208, 212, 448-479	PV Reserve Connection Fault	<ol style="list-style-type: none"> 1. Check whether the corresponding string is of reverse polarity. If so, disconnect the DC switch and adjust the polarity when the string current drops below 0.5 A. 2. Contact Sungrow Customer Service if the preceding causes are ruled out and the fault persists. <p>*The code 28 to code 29 are corresponding to PV1 to PV2 respectively. *The code 448 to code 479 are corresponding to string 1 to string 32 respectively.</p>
532-547, 564-579	PV Reverse Connection Alarm	<ol style="list-style-type: none"> 1. Check whether the corresponding string is of reverse polarity. If so, disconnect the DC switch and adjust the polarity when the string current drops below 0.5 A. 2. Contact Sungrow Customer Service if the preceding causes are ruled out and the alarm persists. <p>*The code 532 to code 547 are corresponding to string 1 to string 16 respectively. *The code 564 to code 579 are corresponding to string 17 to string 32 respectively.</p>

Fault Code	Fault Name	Corrective Measures
548-563, 580-595	PV Abnormal Alarm	<p>Check whether the voltage and current of the inverter is abnormal to determine the cause of the alarm.</p> <ol style="list-style-type: none"> 1. Check whether the corresponding module is sheltered. If so, remove the shelter and ensure module cleanness. 2. Check whether the battery board wiring is loose, if so, make it reliably connected. 3. Check if the DC fuse is damaged. If so, replace the fuse. 4. Contact Sungrow Customer Service if the preceding causes are ruled out and the alarm persists. <p>*The code 548 to code 563 are corresponding to string 1 to string 16 respectively. *The code 580 to code 595 are corresponding to string 17 to string 32 respectively.</p>
37	Excessively High Ambient Temperature	<p>Generally, the inverter will resume operation when the internal or module temperature returns to normal. If the fault persists:</p> <ol style="list-style-type: none"> 1. Check whether the ambient temperature of the inverter is too high; 2. Check whether the inverter is in a well-ventilated place; 3. Check whether the inverter is exposed to direct sunlight. Shield it if so; 4. Check whether the fan is running properly. Replace the fan if not; 5. Contact Sungrow Power Customer Service if the fault is due to other causes and the fault persists.
43	Excessively Low Ambient Temperature	<p>Stop and disconnect the inverter. Restart the inverter when the ambient temperature rises within the operation temperature range.</p>

Fault Code	Fault Name	Corrective Measures
39	Low System Insulation Resistance(Earth Fault)	<p>Wait for the inverter to return to normal. If the fault occurs repeatedly:</p> <ol style="list-style-type: none"> 1. Check whether the ISO resistance protection value is excessively high via the app or the LCD, and ensure that it complies with the local regulations. 2. Check the resistance to ground of the string and DC cable. Take corrective measures in case of short circuit or damaged insulation layer. 3. If the cable is normal and the fault occurs on rainy days, check it again when the weather turns fine. 4. If there are batteries, check whether battery cables are damaged and whether terminals are loose or in poor contact. If so, replace the damaged cable and secure terminals to ensure a reliable connection. 5. Contact Sungrow Customer Service if the preceding causes are ruled out and the fault persists.
106	Grounding Cable Fault	<ol style="list-style-type: none"> 1. Check whether the AC cable is correctly connected. 2. Check whether the insulation between the ground cable and the live wire is normal. 3. Contact Sungrow Customer Service if the preceding causes are ruled out and the fault persists.
88	Electric Arc Fault	<ol style="list-style-type: none"> 1. Disconnect the DC power supply, and check whether any DC cable is damaged, the connection terminal or fuse is loose or there is a weak contact. If so, replace the damaged cable, fasten the terminal or fuse, and replace the burnt component. 2. After performing step 1, reconnect the DC power supply, and clear the electric arc fault via the App or the LCD, after that the inverter will return to normal. 3. Contact Sungrow Customer Service if the fault persists.

Fault Code	Fault Name	Corrective Measures
84	Reverse Connection Alarm of the Meter/CT	<ol style="list-style-type: none"> 1. Check if the meter is wrongly connected. 2. Check if the input and output wiring of the meter is reversed. 3. If the existing system is enabled, please check if the rated power setting of the existing inverter is correct.
514	Meter Communication Abnormal Alarm	<ol style="list-style-type: none"> 1. Check whether the communication cable and the terminals are abnormal. If so, correct them to ensure reliable connection. 2. Reconnect the communication cable of the meter. 3. Contact Sungrow Customer Service if the preceding causes are ruled out and the alarm persists.
323	Grid Confrontation	<ol style="list-style-type: none"> 1. Check whether the output port is connected to actual grid. Disconnect it from the grid if so. 2. Contact Sungrow Customer Service if the preceding causes are ruled out and the fault persists.
75	Inverter Parallel Communication Alarm	<ol style="list-style-type: none"> 1. Check whether the communication cable and the terminals are abnormal. If so, correct them to ensure reliable connection. 2. Reconnect the communication cable of the meter. 3. Contact Sungrow Customer Service if the preceding causes are ruled out and the alarm persists.
7, 11, 16, 19–25, 30–34, 36, 38, 40–42, 44–50, 52–58, 60–69, 85, 87, 92, 93, 100–105, 107– 114, 116–124, 200–211, 248– 255, 300–322, 324–328, 401– 412, 600–603, 605, 608, 612, 616, 620, 622– 624, 800, 802, 804, 807, 1096– 1118	System Fault	<ol style="list-style-type: none"> 1. Wait for the inverter to return to normal. 2. Disconnect the AC and DC switches, and disconnect the battery side switches if there are batteries. Close the AC and DC switches in turn 15 minutes later and restart the system. 3. Contact Sungrow Customer Service if the preceding causes are ruled out and the fault persists.

Fault Code	Fault Name	Corrective Measures
59, 70–74, 76–83, 89, 216–218, 220–233, 432–434, 500–513, 515–518, 635–638, 900, 901, 910, 911, 996	System Alarm	<ol style="list-style-type: none"> The inverter can continue running. Check whether the related wiring and terminal are abnormal, check whether there are any foreign materials or other environmental abnormalities, and take corresponding corrective measures when necessary. If the fault persists, please contact Sungrow Power Customer Service.
264-283	MPPT Reverse Connection	<ol style="list-style-type: none"> Check whether the corresponding string is of reverse polarity. If so, disconnect the DC switch and adjust the polarity when the string current drops below 0.5 A. Contact Sungrow Customer Service if the preceding causes are ruled out and the fault persists. <p>*The code 264 to code 279 are corresponding to string 1 to string 20 respectively.</p>
332-363	Boost Capacitor Overvoltage Alarm	<ol style="list-style-type: none"> The inverter can continue running. Check whether the related wiring and terminals are abnormal, check whether there are any foreign materials or other environmental abnormalities, and take corresponding corrective measures when necessary. <p>If the fault persists, please contact Sungrow Power Customer Service.</p>
364-395	Boost Capacitor Overvoltage Fault	<ol style="list-style-type: none"> Disconnect the AC and DC switches, and disconnect the battery side switches if there are batteries. Close the AC and DC switches in turn 15 minutes later and restart the system. If the fault persists, please contact Sungrow Power Customer Service.

Fault Code	Fault Name	Corrective Measures
1548-1579	String Current Reflex	<ol style="list-style-type: none"> 1. Check whether the number of PV modules of the corresponding string is less than other strings. If so, disconnect the DC switch and adjust the PV module configuration when the string current drops below 0.5 A. 2. Check whether the PV module is shaded; 3. Disconnect the DC switch to check whether the open circuit voltage is normal when the string current drops below 0.5 A. If so, check the wiring and configuration of the PV module, 4. Check whether the orientation of the PV module is abnormal.
1600 - 1615, 1632 - 1655	PV Grounding Fault	<ol style="list-style-type: none"> 1. When the fault occurs, it is forbidden to directly disconnect the DC switch and unplug PV terminals when the direct current is greater than 0.5 A; 2. Wait until the direct current of the inverter falls below 0.5 A, then disconnect the DC switch and unplug the faulty strings; 3. Do not reinsert the faulty strings before the grounding fault is cleared; 4. If the fault is not caused by the foregoing reasons and still exists, contact Sungrow Customer Service.
1616	System Hardware Fault	<ol style="list-style-type: none"> 1. It is prohibited to disconnect the DC switch when the DC current is greater than 0.5 A when the fault occurs. 2. Disconnect the DC switch only when the inverter DC side current drops below 0.5 A. 3. It is prohibited to power up the inverter again. Please contact Sungrow Customer Service.

Once a fault occurs to the optimizer or RSD, the fault information is displayed on the App.

Fault Code	Fault Name	Possible Cause	Corrective Method
4	Input overvoltage	The PV voltage is higher than the set protection value	Check whether the open-circuit voltage of the PV module connected to the optimizer exceeds the maximum input voltage allowed by the optimizer.

Fault Code	Fault Name	Possible Cause	Corrective Method
512	Hardware fault	A hardware fault occurs to the optimizer	Please contact Sungrow Customer Service.
1024	Update failed	The optimizer software fails to upgrade	1. Check the light condition, and update the optimizer again if the light is normal. 2. If the fault persists, please contact Sungrow Customer Service.



- If there is a string current backfeed fault, first check whether the optimizer is offline.
- Contact the dealer if the measures listed in the “Troubleshooting Method” column have been taken but the problem persists. Contact SUNGROW if the dealer fails to solve the problem.

9.2 Maintenance

9.2.1 Maintenance Notices

DANGER

Risk of inverter damage or personal injury due to incorrect service!

- Be sure to use special insulation tools when perform high-voltage operations.
- Before maintenance, disconnect the AC circuit breaker on the grid side and then the DC switch. If a fault that may cause personal injury or device damage is found before maintenance, disconnect the AC circuit breaker and wait until the night before operating the DC switch. Otherwise, a fire inside the product or an explosion may occur, causing personal injuries.
- Turn the DC switch from ON to OFF and continue to turn it 20 degrees counter-clockwise, the DC switch can be locked here. (For countries “AU” and “NZ”)
- After the inverter is powered off for 5 minutes, measure the voltage and current with professional instrument. Only when there is no voltage nor current can operators who wear protective equipment operate and maintain the inverter
- Even if the inverter is shut down, it may still be hot and cause burns. Wear protective gloves before operating the inverter after it cools down.

⚠ DANGER

When maintaining the product, it is strictly prohibited to open the product if there is an odor or smoke or if the product appearance is abnormal. If there is no odor, smoke, or obvious abnormal appearance, repair or restart the inverter according to the alarm corrective measures. Avoid standing directly in front of the inverter during maintenance.

⚠ CAUTION

To prevent misuse or accidents caused by unrelated personnel: Post prominent warning signs or demarcate safety warning areas around the inverter to prevent accidents caused by misuse.

NOTICE

Restart the inverter only after removing the fault that impairs safety performance. As the inverter contains no component parts that can be maintained, never open the enclosure, or replace any internal components. To avoid the risk of electric shock, do not perform any other maintenance operations beyond this manual. If necessary, contact your distributor first. If the problem persists, contact SUNGROW. Otherwise, the losses caused is not covered by the warranty.

NOTICE

Touching the PCB or other static sensitive components may cause damage to the device.

- Do not touch the circuit board unnecessarily.
- Observe the regulations to protect against electrostatic and wear an anti-static wrist strap.

9.2.2 Quick Shutdown

The PV system can perform a quick shutdown, reducing the output voltage of strings to below 30 V within 30 s.

Triggering methods of quick shutdown:

- Method 1: Turn off the AC circuit breaker between the inverter and the grid.
- Method 2: Connect DI and PGND in COM2 port to trigger quick shutdown. Disconnect DI and PGND to exit the quick shutdown mode.

NOTICE

- **The quick shutdown is not supported if optimizers are configured for some PV modules.**
- **Please check regularly whether the quick shutdown function is normal.**

9.2.3 Routine Maintenance

Item	Method	Period
Device clean	Check whether the air outlet and heat sink are blocked by dust and other objects. Check if the air inlet and outlet are normal. Clean the air inlet and outlet, if necessary.	Six months to a year (depend on the dust contents in air)
Fans	Check whether there is a fan alarm on the App. Check whether there is any abnormal noise when the fan is rotating. Clean or replace the fans if necessary (see the following section).	Once a year
Cable entry	Check whether the cable entry is insufficiently sealed or the gap is excessively large, and reseal the entry when necessary.	Once a year
Electrical connection	Check whether cables are loose or fall off. Check whether the cable is damaged, especially the part in contact with the metal enclosure.	Six months to a year

9.2.4 Cleaning Air Inlet and Outlet

A significant amount of heat is generated when the inverter is working.

In order to maintain good ventilation, please check to make sure the air inlet and outlet are not blocked.

Clean the air inlet and outlet with soft brush or vacuum cleaner if necessary.

9.2.5 Fan Maintenance

⚠ WARNING

- **Power off the inverter and disconnect it from all power supplies before maintaining fans.**
- **After the inverter is powered off for 10 minutes, measure the voltage and current with professional instrument. Only when there is no voltage nor current can operators who wear protective equipment operate and maintain the inverter.**
- **Fan maintenance must be performed by professionals.**

Fans inside the inverter are used to cool the inverter during operation. If the fans do not operate normally, the inverter may not be cooled down and inverter efficiency may decrease. Therefore, it is necessary to clean dirty fans and replace the broken fans in a timely manner.

The operation procedure is as follows:

step 1 Stop the inverter (see [8.1 Disconnecting the Inverter](#)).

step 2 Loosen the screw on the sealing plate of the fan module.

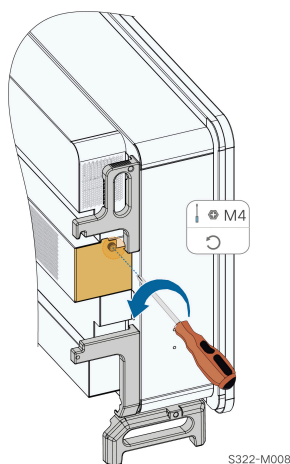

step 3 Press the tab of the latch hook, unplug the cable connection joint outwards, and loosen the screw on the fan holder.

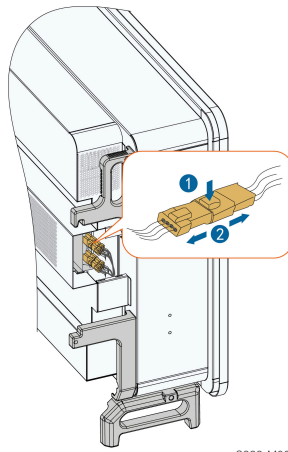

step 4 Loosen screws on the side of the fan module.

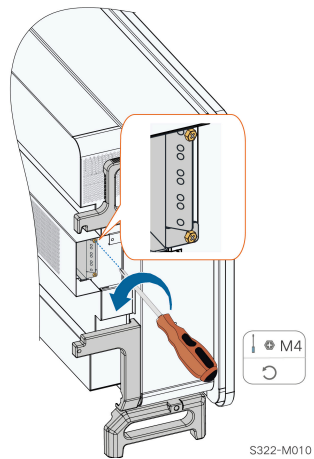

step 5 Pull out the fans. Clean them with a soft brush or vacuum cleaner, and replace them when necessary.

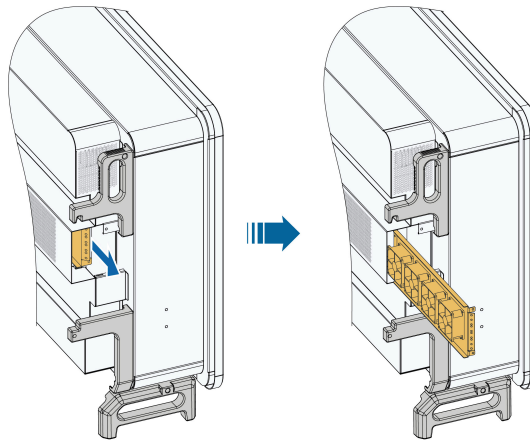

S322-M011

-- End

10 Appendix

10.1 Technical Data

Parameters	SG125CX-P2	SG110CX-P2	SG75CX-P2
Input (DC)			
Recommended max. PV input power	175 kW	154 kW	105 kW
Max. PV input voltage	1100 V		
Min. PV input voltage / Startup input voltage	180 V / 200 V		
Rated PV input voltage	600 V		
MPP voltage range	180 ~ 1000 V		
MPP voltage range for rated power	550 V ~ 850 V ⁽¹⁾		
No. of independent MPP inputs	12		8
No. of PV strings per MPPT	2		2
Max. PV input current	360 A (30 A * 12)		240 A (30 A * 8)
Max. DC Short-circuit current	480 A (40 A * 12)		320 A (40 A * 8)
Max. current for DC connector	30A		
Output (AC)			
Max. AC Output power	125 kVA	110 kVA	75 kVA
Rated AC output apparent power	125 kVA	110 kVA	75 kVA
Max. AC output current	181.1 A	167.1 A (For Latin America)	113.9 A
Rated AC output current(at 230V)	181.1 A	159.4 A	108.7 A
Rated AC voltage	3 / N / PE, 230 / 400 V ; 3 / N / P E, 240 / 415	3 / N / PE, 220 / 380 V, 230 / 400 V	
AC voltage range	320 – 480V	304 - 456V (380V) / 320 - 480 V (400V)	

Parameters	SG125CX-P2	SG110CX-P2	SG75CX-P2
Rated grid frequency	50 Hz / 60 Hz		
Grid frequency range	45 – 55 Hz / 55 – 65 Hz		
Harmonic (THD)	< 3 % (at rated power)		
Power factor at rated power / Adjustable power factor	> 0.99 / 0.8 leading – 0.8 lagging		
Feed-in phases / connection phases	3 / 3-N-PE		
Efficiency			
Max. efficiency / European efficiency	98.5% / 98.3%	98.6% / 98.3%	
Protection			
Grid monitoring	Yes		
DC reverse polarity protection	Yes		
AC short circuit protection	Yes		
Leakage current protection	Yes		
Surge protection	DC Type I + II / A C Type II		
Ground fault monitoring	Yes		
DC switch	Yes		
PV string monitoring	Yes		
Q at night function	Yes		
Arc fault circuit interrupter (AFCI)	Yes		
PID recovery function	Yes		
Optimizer compatibility ⁽⁹⁾	Optional	/	/
Protective Class	I		
Overvoltage Category	DC II/AC III		
Active Anti-Islanding Method	Frequency Shift		
General Data			
Dimensions (W*H*D)	1020 * 795* 360 mm		
Mounting Method	Wall-mounting bracket		

Parameters	SG125CX-P2	SG110CX-P2	SG75CX-P2
Weight	≤93 kg	≤93 kg	82 kg
Topology	Transformerless		
Degree of protection	IP66		
Corrosion	C5		
Night power consumption	< 5 W		
Operating ambient temperature range	-30 to 60 °C		
Allowable relative humidity range (non-condensing)	0 ~ 100%		
Cooling method	Smart forced air cooling		
Max. operating altitude	4000 m (>3000 m derating)		
Display	LED, Bluetooth + APP		
Communication	RS485 / Optional: WLAN, Ethernet		
DC connection type	Evo2 (Max. 6 mm ²)		
AC connection type	OT / DT terminal (Max. 240 mm ²)		
Grid Support	Q at night function, LVRT, HVRT, active & reactive power control and power ramp rate control		

Note(1):The voltage difference between MPPTs should be less than 80 V. The voltage of the configured string should be higher than the lower limit of the rated MPPT voltage.

Note(9):For optimizer compatibility, please consult Sungrow before placing an order.

Parameters	SG110CX-P2 ⁽²⁾
Input (DC)	
Recommended max. PV input power	154 kW
Max. PV input voltage*	1100 V
Min. PV input voltage / Startup input voltage	180 V / 200 V
Rated PV input voltage	600 V
MPP voltage range**	180 – 1000 V
No. of independent MPP inputs	12
No. of PV strings per MPPT	2
Max. PV input current	360 A (30 A /30 A/30 A/30 A/30 A/30 A/30 A/30 A/30 A/30 A/30 A/30 A)

Parameters	SG110CX-P2 ^(2)
Max.DC Short-circuit current	480 A (40 A/40 A/40 A/40 A/40 A/40 A/40 A/40 A/40 A/40 A)
Max. current for DC connector	30 A
Output (AC)	
Rated AC output power	110 kW
Max. AC output apparent power	110 kVA
Max. AC output current	158.8 A
Rated AC voltage	3 / N / PE, 230 / 400 V
AC voltage range	320 – 480 V
Rated grid f requency / Grid f re- quency range	50 Hz / 45 – 55 Hz
Harmonic (THD)	< 3 % (at rated power)
Power factor at rated power / Ad- justable power factor	> 0.99 / 0.8 leading – 0.8 lagging
Feed-in phases /AC connection	3 / 3-N-PE
Efficiency	
Max. efficiency / European effi- ciency	98.5 % / 98.3 %
Protection	
Grid monitoring	Yes
DC reverse polarity protection	Yes
AC short circuit protection	Yes
Leakage current protection	Yes
Surge protection	DC Type II / AC Type II
Ground fault monitoring	Yes
DC switch	Yes
PV String current monitoring	Yes
PID recovery function	Yes
Arc fault circuit interrupter (AFCI)	Yes
General Data	
Dimensions (W*H*D)	1020 * 795* 360 mm
Weight	≤93 kg
Mounting method	Wall-mounting bracket
Topology	Transformerless
Degree of protection	IP66

Parameters	SG110CX-P2 (2)
Corrosion	C5
Night power consumption	< 5 W
Operating ambient temperature range	-30 to 60 °C
Allowable relative humidity range (non-condensing)	0 – 100 %
Cooling method	Smart forced air cooling
Max. operating altitude	4000 m
Display	LED, Bluetooth+APP
Communication	RS485 / WLAN(Optional) / Ethernet (Optional)
DC connection type	Evo2 (Max. 6 mm ²)
AC connection type	OT or DT terminal (Max.240 mm ²)
AC cable specification	Outside diameter 30~60mm
Grid compliance	IEC 62109, IEC 61727, IEC 62116, IEC 60068, IEC 61683, IEC 61000-6-3, AS/NZS4777.2:2020, IEC 63027
Grid Support	Q at night function, LVRT, HVRT, active & reactive power control and power ramp rate control
Country of manufacture	China

Note(2):For Australia.

*:Input voltage exceeding the MPPT operating voltage range triggers inverter protection

**:.Please refer to the user manual for the full load MPPT voltage range

Parameters	SG125CX-P2 (4)
Input (DC)	
Recommended max. PV input power	175 kW
Max. PV input voltage	1100 V
Min. PV input voltage / Startup input voltage	180 V / 200 V
Rated PV input voltage	600 V
MPP voltage range	180 ~ 1000 V
MPP voltage range for rated power	550 V ~ 850 V ⁽⁵⁾
No. of independent MPP inputs	12
No. of PV strings per MPPT	2

Parameters	SG125CX-P2⁽⁴⁾
Max. PV input current	360 A (30 A *12)
Max.DC Short-circuit current	480 A (40 A * 12)
Max. current for DC connector	30A
Output (AC)	
Max. AC Output power	125 kVA (415 V @ 50 °C) ⁽⁶⁾
Rated AC output apparent power	125 kVA (415 V @ 50 °C) ⁽⁶⁾
Max. AC output current	181.1 A
Rated AC output current(at 230V)	181.1 A
Rated AC voltage	3 / N / PE, 230 / 400 V 3 / N / PE, 240 / 415 V
AC voltage range	320 – 480V
Rated grid frequency	50 Hz / 60 Hz
Grid frequency range	45 – 55 Hz / 55 – 65 Hz
Harmonic (THD)	< 3 % (at rated power)
Power factor at rated power / Adjustable power factor	> 0.99 / 0.8 leading – 0.8 lagging
Feed-in phases / connection phases	3 / 3-N-PE
Efficiency	
Max. efficiency / European efficiency	98.5% / 98.3%
Protection	
Grid monitoring	Yes
DC reverse polarity protection	Yes
AC short circuit protection	Yes
Leakage current protection	Yes
Surge protection	DC Type I + II / A C Type II
Ground fault monitoring	Yes
DC switch	Yes
PV string monitoring	Yes
Q at night function	Yes
Arc fault circuit interrupter (AFCI)	Yes
PID recovery function	Yes
Optimizer compatibility ⁽⁹⁾	Optional
Protective Class	I

Parameters	SG125CX-P2 ⁽⁴⁾
Overvoltage Category	DC III/AC III
Active Anti-Islanding Method	Frequency Shift
General Data	
Dimensions (W*H*D)	1020 * 795* 360 mm
Mounting Method	Wall-mounting bracket
Weight	87 kg
Topology	Transformerless
Degree of protection	IP66
Corrosion	C5
Night power consumption	< 5 W
Operating ambient temperature range	-30 to 60 °C
Allowable relative humidity range (non-condensing)	0 ~ 100%
Cooling method	Smart forced air cooling
Max. operating altitude	4000 m (>3000 m derating)
Display	LED, Bluetooth + APP
Communication	RS485 / Optional: WLAN, Ethernet
DC connection type	Evo2 (Max. 6 mm ²)
AC connection type	OT / DT terminal (Max. 240 mm ²)
AC cable specification	Outside diameter 30~60mm
Grid Support	Q at night function, LVRT, HVRT, active & reactive power control and power ramp rate control

Note(4):For India.

Note(5):The voltage difference between MPPTs should be less than 80 V. The voltage of the configured string should be higher than the lower limit of the rated MPPT voltage.

Note(6):PV input voltage need over 630 VDC.

Note(9):For optimizer compatibility, please consult Sungrow before placing an order.

Parameters	SG110CX-P2 ⁽⁷⁾	SG75CX-P2 ⁽⁷⁾
Input (DC)		
Recommended max. PV input power	154 kW	105 kW
Max. PV input voltage	1100 V	

Parameters	SG110CX-P2 ⁽⁷⁾	SG75CX-P2 ⁽⁷⁾
Min. PV input voltage / Startup input voltage	180 V / 200 V	
Rated PV input voltage	600 V	
MPP voltage range	180 ~ 1000 V	
MPP voltage range for rated power	550 V ~ 850 V ⁽⁸⁾	
No. of independent MPP inputs	12	8
No. of PV strings per MPPT	2	2
Max. PV input current	360 A (30 A * 12)	240 A (30 A * 8)
Max.DC Short-circuit current	480 A (40 A * 12)	320 A (40 A * 8)
Max. current for DC connector	20A	
Output (AC)		
Max. AC Output power	110 kVA	75 kVA
Rated AC output apparent power	110 kVA	75 kVA
Max. AC output current	167.1 A	113.9 A
Rated AC output current (at 220V)	166.7 A	113.6 A
Rated AC voltage	3 / N / PE, 220 / 380 V	
AC voltage range	304 - 456V (380V)	
Rated grid frequency	50 Hz / 60 Hz	
Grid frequency range	45 – 55 Hz / 55 – 65 Hz	
Harmonic (THD)	< 3 % (at rated power)	
Power factor at rated power / Adjustable power factor	> 0.99 / 0.8 leading – 0.8 lagging	

Parameters	SG110CX-P2 ⁽⁷⁾	SG75CX-P2 ⁽⁷⁾
Feed-in phases / connection phases	3 / 3-N-PE	
Efficiency		
Max. efficiency / European efficiency	98.6% / 98.3%	
Protection		
Grid monitoring	Yes	
DC reverse polarity protection	Yes	
AC short circuit protection	Yes	
Leakage current protection	Yes	
Surge protection	DC Type I + II / A C Type II	
Ground fault monitoring	Yes	
DC switch	Yes	
PV string monitoring	Yes	
Q at night function	Yes	
Protective Class	I	
Overvoltage Category	DC II/AC III	
Active Anti-Islanding Method	Frequency Shift	
General Data		
Dimensions (W*H*D)	1020 * 795* 360 mm	
Mounting Method	Wall-mounting bracket	
Weight	87 kg	82 kg
Topology	Transformerless	
Degree of protection	IP66	
Corrosion	C5	
Operating ambient temperature range	-30 to 60 °C	

Parameters	SG110CX-P2 ⁽⁷⁾	SG75CX-P2 ⁽⁷⁾
Allowable relative humidity range (non-condensing)	0 ~ 100%	
Cooling method	Smart forced air cooling	
Max. operating altitude	4000 m (>3000 m derating)	
Display	LED, Bluetooth + APP	
Communication	RS485 / WLAN / Optional: Ethernet	
DC connection type	Evo2 (Max. 6 mm ²)	
AC connection type	OT / DT terminal (Max. 240 mm ²)	
Grid Support	Q at night function, LVRT, HVRT, active & reactive power control and power ramp rate control	

Note(7):For Latin America.

Note(8):The voltage difference between MPPTs should be less than 80 V. The voltage of the configured string should be higher than the lower limit of the rated MPPT voltage.

10.2 Wiring Distance of DI Dry Contact

The wiring distance between DI dry contact terminals must meet the requirements in the table below. The wiring distance L is the total length of all DI signal cables.

$$L = 2 \sum_{k=1}^n L_k$$

L_k refers to the cable length in one direction between the DI dry contact terminal of the k^{th} inverter and the corresponding terminal of the $(k-1)^{\text{th}}$ inverter.

table 10-1 Correspondence Between Inverter Quantity and Maximum Wiring Distance

Number of Inverter	Maximum Wiring Distance(unit:m)	
	16AWG / 1.31mm ²	17AWG / 1.026mm ²
1	13030	10552
2	6515	5276
3	4343	3517
4	3258	2638
5	2606	2110
6	2172	1759
7	1861	1507

Number of In- verter	Maximum Wiring Distance(unit:m)	
	16AWG / 1.31mm ²	17AWG / 1.026mm ²
8	1629	1319
9	1448	1172
10	1303	1055
11	1185	959
12	1086	879
13	1002	812
14	931	754
15	869	703
16	814	660
17	766	621
18	724	586
19	686	555
20	652	528
21	620	502
22	592	480
23	567	459
24	543	440
25	521	422

NOTICE

In case the specification of the cable used is not included in the table above, when there is only one inverter, ensure that the line impedance of the input node is less than 300Ω; and when there are multiple inverters connected in the daisy chain, ensure that the impedance is less than 300Ω/number of inverter.

10.3 Quality Assurance

When product faults occur during the warranty period, SUNGROW will provide free service or replace the product with a new one.

Evidence

During the warranty period, the customer shall provide the product purchase invoice and date. In addition, the trademark on the product shall be undamaged and legible. Otherwise, SUNGROW has the right to refuse to honor the quality guarantee.

Conditions

- After replacement, unqualified products shall be processed by SUNGROW.
- The customer shall give SUNGROW a reasonable period to repair the faulty device.

Exclusion of Liability

In the following circumstances, SUNGROW has the right to refuse to honor the quality guarantee:

- The free warranty period for the whole machine/components has expired.
- The device is damaged during transport.
- The device is incorrectly installed, refitted, or used.
- The device operates in harsh conditions beyond those described in this manual.
- The fault or damage is caused by installation, repairs, modification, or disassembly performed by a service provider or personnel not from SUNGROW.
- The fault or damage is caused by the use of non-standard or non-SUNGROW components or software.
- The installation and use range are beyond stipulations of relevant international standards.
- The damage is caused by unexpected natural factors.

For faulty products in any of above cases, if the customer requests maintenance, paid maintenance service may be provided based on the judgment of SUNGROW.



Product data such as product dimensions are subject to change without prior notice. The latest documentation from SUNGROW should take precedence in case of any deviation.

10.4 Contact Information

In case of questions about this product, please contact us.

We need the following information to provide you the best assistance:

- Model of the device
- Serial number of the device
- Fault code/name
- Brief description of the problem

For detailed contact information, please visit: <https://en.sungrowpower.com/contactUS>

SUNGROW

Sungrow Power Supply Co., Ltd.
www.sungrowpower.com