

M-ELV Battery

MS-7K-U-1P/ MS-7K-U-3P /

MS-7K-U-1P + MC100PRO-S1P / MS-7K-U-3P + MC100PRO-T3P

User Manual

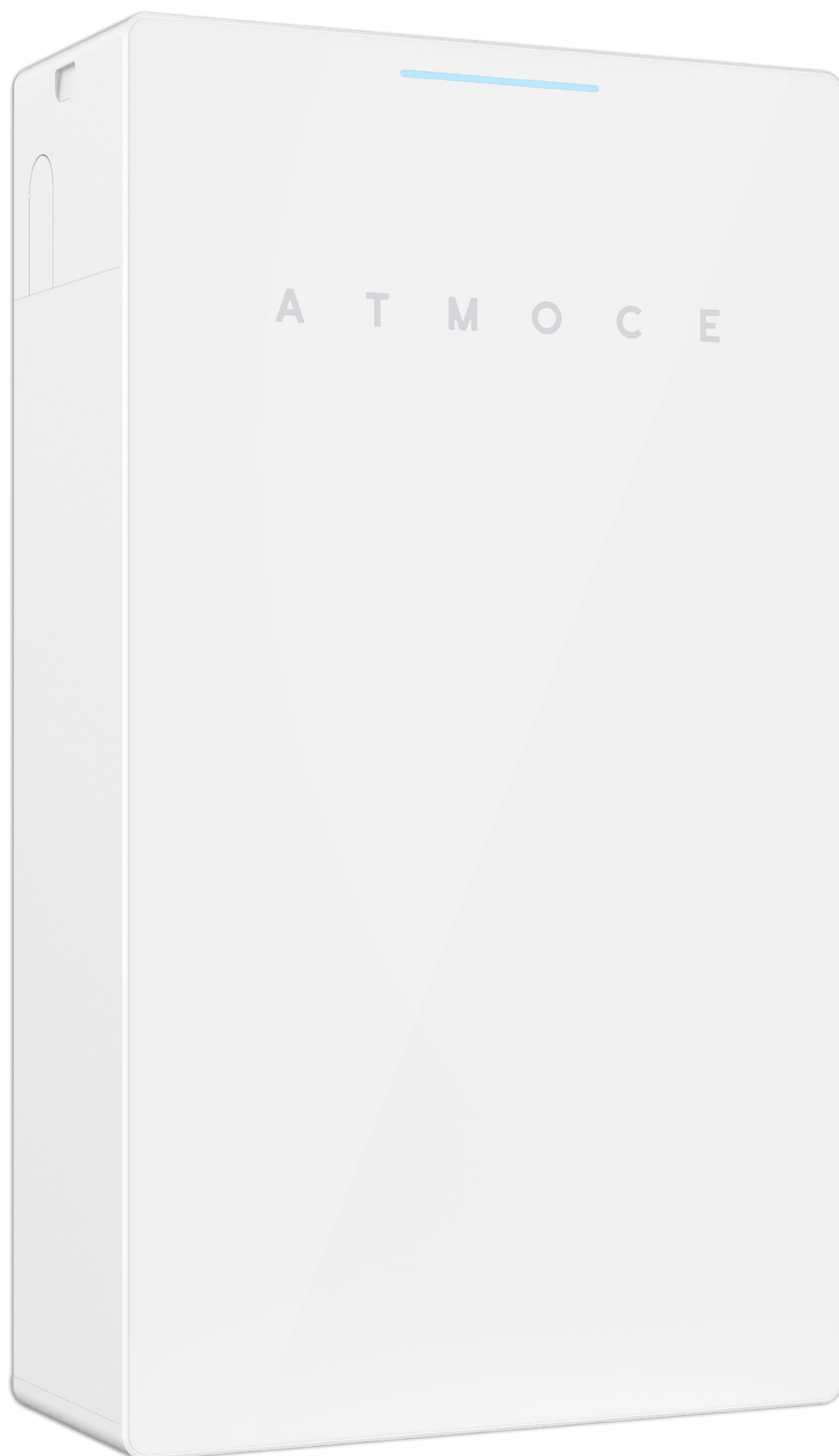

ATMOCE

About This Document

Corporate Contact Information

Company: ATMOCE Holding B.V.

Address: Rokin 92-96, 1012 KZ Amsterdam, the Netherlands

Email: support@atmoce.com

Telephone: +31 20 241 6207

Disclaimer

- Product information is subject to change without prior notice. Every effort has been made in the preparation of this document to ensure accuracy of the content, but all statements, information, and recommendations in this document do not constitute a warranty of any kind, express or implied.
- For optimum reliability and to meet warranty requirements, this product must be installed in accordance with the instructions in this manual.
- For more information about the warranty, Visit <https://www.atmoce.com/en/policy/war-ranty-policy>

Applicable Scope

- This manual is intended for professional installation and maintenance personnel only.
- This manual mainly introduces the assembly, installation, configuration, maintenance, and troubleshooting methods of the following types of battery: MS-7K-U-1P/ MS-7K-U-3P / MS-7K-U-1P + MC100PRO-S1P / MS-7K-U-3P + MC100PRO-T3P

Revision History

	Date	Version	Description
1	2025-07-23	Rev. 1.0.1	<ol style="list-style-type: none">1. Revise the voltage range of the M-ELV Battery.2. Revise the battery system introduction.3. Revise the nameplate information.4. Revise the items of the package list.5. Revise the installation steps.6. Add the description of the self-consumption mode and TOU mode.7. Add the notes of the SoC.8. Revise the information of the data sheet.
2	2025-04-11	Rev. 1.0.0	<ol style="list-style-type: none">1. First release

Contents

About This Document	02
Corporate Contact Information	02
Disclaimer	02
Applicable Scope	02
Revision History	03
Contents	04
Safety Information	07
1.1 Statement	07
1.2 Safety Labels	07
1.3 Personal safety instructions	08
1.4 Battery Safety Instructions	09
1.5 Cable Safety Instructions	10
1.6 Environment Instructions	11
Product Information	12
2.1 M-ELV Battery Introduction	12
Storage Requirements	18
M-ELV Battery Installation	19
4.1 Pre-installation Requirements	19
4.2 Take out the M-Battery	23
4.3 Mount the M-Battery	24
4.4 Remove the cover of the wiring cabinet	28
4.5 Remove the knockout	29
4.6 Wire the cables	30
4.7 Close the cover of the wiring cabinet	35
4.8 Remove the knockout of the upper cover	36
4.9 Close the upper cover	37
4.10 Power on the system	38
4.11 Activate the system	38
4.12 System level Battery Parameter Settings	39

Contents

MC100PRO-S1P Installation	40
5.1 MC100PRO-S1P Introduction	40
5.2 Pre-installation Requirements	41
5.3 Mount the M-CombinerPro	44
5.4 Remove the protective panel	45
5.5 Wire to the M-CombinerPro	46
5.6 Power on the system	55
5.7 Activate the system	56
5.8 Close the M-CombinerPro	56
5.9 LED indicator description	57
MC100PRO-T3P Installation	58
6.1 MC100PRO-T3P Introduction	58
6.2 Pre-installation Requirements	59
6.3 Mount the M-CombinerPro	62
6.4 Remove the protective panel	63
6.5 Wire to the M-CombinerPro	64
6.6 Power on the system	73
6.7 Activate the system	74
6.8 Close the M-CombinerPro	74
6.9 LED indicator description	75
DRED Device support	76
7.1 DRM Interface	76
7.2 Combined with CombinerPro	77
7.3 Combined with Gateway	78
Operation and Maintenance	79
8.1 M-ELV Battery Working Mode	79
8.2 Parameter Setting	81
8.3 System Power-Off	90
8.4 Routine Maintenance	91

Contents

Troubleshooting	92
9.1 LED Indicator Description	92
9.2 Check the Alert Codes	93
9.3 Alert Codes List	94
9.4 Maintenance	97
Technical Data	101
10.1 MS-7K-U-1P/MS-7K-U-3P Data Sheet	101
10.2 MC100PRO-S1P/MC100PRO-T3P Data Sheet	103
Appendix 1: Recommended wire diameter	105
Appendix 2: Terms and Abbreviations	106





Safety Information

1.1 Statement

- Before installing or using the M-Battery, please carefully read the user manual, all instructions, safety labels on the product, and any available safety manuals. Failure to follow these safety instructions may result in personal injury, damage to the equipment, or invalidation of the warranty.
- DANGER, WARNING, CAUTION, and NOTE in this manual must be adhered to. You must also comply with relevant international, national, or regional standards and industry practices. M-Battery assumes no responsibility for any violation of safe operation requirements or safety standards regarding the design, manufacture, and use of the equipment.
- This equipment should only be used in environments that meet its design specifications; any failure, abnormal operation, or damage to components arising from non-compliance will not be covered by the warranty.
- All operations including transportation, storage, installation, operation, use, maintenance, etc., should comply with applicable laws, regulations, standards, and specifications.

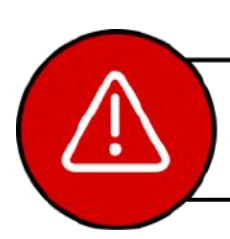
1.2 Safety Labels

To reduce the risk of electric shock and ensure the safe installation and operation of the M-Battery system, the following safety symbols are used throughout this manual to indicate hazardous conditions and important safety instructions:

- | | |
|--|---|
|  Danger | A label indicates a hazard with a high level of risk. Failure to avoid this hazard may result in serious personal injury or death. |
|  Warning | A label indicates a hazard with a medium level of risk. Failure to avoid this hazard may result in serious personal injury or death. |
|  Caution | A label indicates a hazard with a low level of risk. Failure to avoid this hazard may result in serious personal injury or death. |
|  Note | A label indicates a safety hazard or risk of device damage. Failure to avoid this hazard may result in equipment damage, data loss, reduced performance, or other consequences, but does not involve personal injury. |

1.3 Personal safety instructions



- **No live electrical work:** The installation process must never be performed with live electricity. It is prohibited to install or remove cables while the system is energized. If the cable core comes into contact with the conductor, it can cause electric arcs or sparks, which can lead to fire or personal injury.
- **Risk of Fire or Electric Shock:** When the equipment is powered on, improper or unregulated operation can result in fire, electric shock, or explosion, potentially causing injury, death, or property damage.
- **Work with Assistance:** Always have someone nearby when working with electrical equipment. They should be within earshot or close enough to assist in case of emergency. Remove any metal jewelry (rings, bracelets, necklaces, watches) when working with the M-Battery or any electrical components.
- **Power Off Before Installation:** Do not apply power to the equipment until installation is fully completed and verified by a qualified person.



- **Use Personal Protective Equipment (PPE):** Ensure that all workers use appropriate protective gear, such as protective clothing, insulated footwear, goggles, helmets, and insulated gloves, during installation or maintenance operations.
- **Adhere to Warnings and Precautions:** Never ignore warnings, cautions, or precautionary measures indicated in the manuals or on the equipment itself.
- **Take Immediate Action in Case of Malfunction:** If any malfunction is detected during operation that could lead to personal injury or equipment damage, immediately stop the operation, report it to the supervisor, and implement the necessary safety measures.

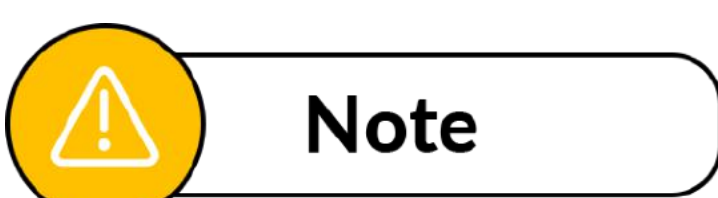

- **Proper Installation by Qualified Personnel Only:** Installation and maintenance must only be performed by trained professionals. M-Battery is not liable for any loss or damage caused by improper use, installation, or misuse of the product.
- **Training Requirements:** Personnel responsible for the installation and maintenance of the M-Battery must undergo proper training to ensure they understand safe operation methods, relevant safety precautions, and local standards and regulations.

1.4 Battery Safety Instructions



- **Unauthorized Repair Prohibited:** Do not attempt to repair the M-Battery without authorization, as it contains no user-repairable components. Unauthorized disassembly, repair, or destruction of the device will void the warranty. In case of malfunction, please contact Atmoce for technical assistance.
- **Authorized Use Only:** Only use the M-Battery as specified by Atmoce. Unauthorized use may result in equipment damage or personal injury.
- **Use Approved Accessories Only:** Only use accessories approved by Atmoce. The use of unauthorized accessories may cause equipment damage or personal injury.
- **Power Off Before Work:** Since the M-Battery is powered by multiple sources, ensure all circuit breakers are turned off before starting any installation, maintenance, or cleaning work.
- **Do Not Operate If Damaged:** Do not operate the M-Battery if its appearance or internal components are damaged. Ensure the device is intact before use.



- **Inspect Cables and Connectors:** Regularly inspect cables and connectors to ensure they are in good condition. Do not operate the M-Battery with damaged or non-compliant cables or connectors.
- **Do Not Disassemble the Enclosure:** Do not disassemble the M-Battery enclosure or protective panels unless necessary for maintenance.

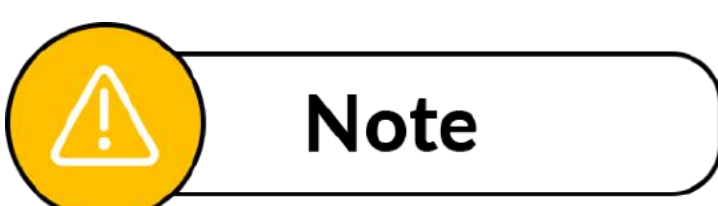

- **Compliance with Installation Regulations:** When installing the M-Battery, ensure compliance with all applicable installation standards and local electrical regulations.
- **Temperature Limitations:** The M-Battery is suitable for use in environments with a maximum ambient temperature of 55°C. Ensure the installation environment meets this temperature limit.
- **Use of Suitable Wiring:** When installing the M-Battery, use copper wiring with a temperature resistance of 90°C or higher. Ensure the wiring meets local electrical standards.
- **Cable and Connector Safety:** Choose cables that meet safety requirements based on circuit breaker parameters. Ensure cables and connectors are in good condition and operate within rated specifications.
- **Grid Connection:** Do not connect the M-Battery to the grid or AC circuit until all installation steps are completed and approval has been obtained from the utility company.

1.5 Cable Safety Instructions



- **Disconnect Power Before Installation:** Do not attempt to install or work with cables unless the circuit is disconnected. Always ensure the power is off before working on any electrical connections.
- **Avoid Damaging the Cable:** Take care not to damage the copper conductor of the cable when stripping the sheath. Damaged wires may result in improper system functionality or failure.



- **Check AC and DC Wiring:** Ensure that all AC wiring are correct and free of any pinches, shorts, or damage. Verify that all AC junction boxes are properly closed and secured.
- **Ensure Proper Cable Connections:** All cables must be securely connected, well-insulated, and meet the appropriate specifications for the system.

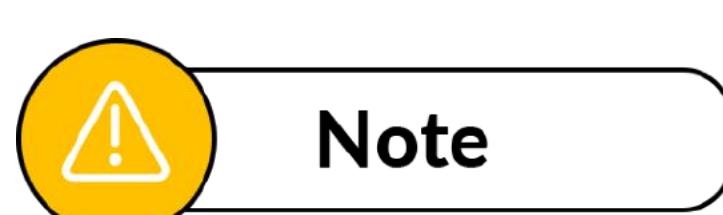

- **Compliance with Local Standards:** Cable selection and routing must comply with local laws, regulations, and industry standards.
- **Respect Cable Bending Radius:** When routing cables, ensure the minimum bending radius is 8x the cable's outer diameter (8xOD).
- **Replace Insufficient Cable Length:** If the power cable length is found to be insufficient, replace it with a properly sized cable. Joints or welding points in the power cable are strictly prohibited.
- **Avoid Tension on Cable Terminal:** Do not expose cable terminals to continuous tension. Avoid pulling or bending the cable at the connection points.
- **Smooth Cable Crossing Holes:** Ensure that cable crossing holes are free of sharp edges to prevent damage from burrs or other sharp objects.
- **Keep the Wire Cabinet Clean:** Always keep the wire cabinet free from dirt, debris, and contaminants. Prevent dirt or debris from entering the connectors during installation and operation.
- **Compliance with Local Regulations:** Ensure all installations and maintenance comply with national and local electrical regulations.

1.6 Environment Instructions



- **Avoid Hazardous Environments:** Do not place the M-Battery in environments with flammable or explosive gases, vapors, or fumes. Never perform any operations in such environments.
- **Explosion Risk:** Do not install or use the M-Battery in a potentially explosive environment. Ensure the equipment is not exposed to conditions that could lead to combustion or detonation.
- **Heat and Ignition Sources:** Avoid placing the equipment near heat sources, such as fireworks, candles, heaters, or other devices that generate heat. The heat produced by the equipment may cause damage or create a fire hazard.
- **Avoid Direct Sunlight Exposure:** Do not expose terminals or connectors to direct sunlight, as this may lead to overheating or degradation of materials.

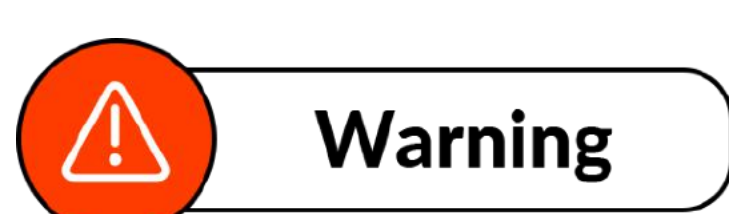

- **Weather Conditions:** Do not attempt to install or use the M-Battery in adverse weather conditions, including rain, snow, or extreme temperatures. Ensure the equipment is installed in dry, stable conditions.
- **Protect from Pressurized Liquids:** Do not expose terminals or connectors to directed pressurized liquids (e.g., water jets). Ensure the equipment is shielded from water or other liquids.
- **Avoid Immersion in Liquids:** Never immerse the terminals, connectors, or any part of the M-Battery in liquid, as this could cause malfunction or permanent damage.
- **Corrosive and Volatile Environments:** Do not install the M-Battery in areas with volatile gases, corrosive substances, or organic solvents. Such environments could degrade the equipment or create safety hazards.
- **Avoid Harsh Environmental Factors:** Do not install the M-Battery in areas subject to strong vibrations, excessive noise, or strong electromagnetic field interference.
- **Sturdy Mounting Surface:** Ensure that the mounting surface for the M-Battery is stable and capable of bearing the equipment's weight. Proper installation on a secure surface prevents equipment malfunction or damage.
- **Remove Packing Materials:** After installation, ensure that all packaging materials such as cardboard boxes, foam, plastic, and cable ties are removed from the equipment area to maintain a clean and safe environment.

Product Information

2.1 M-ELV Battery Introduction

2.1.1 Overview

The ATMOCE MS-7K-U-1P/ MS-7K-U-3P battery is a fully integrated system with a usable energy capacity of 7.0 kWh. It supports on-grid systems, offering self-consumption, TOU and grid ancillary services modes that enables homeowners to achieve energy independence by generating and utilizing their energy while participating in grid services. Combined with MC100PRO-S1P / MC100PRO-T3P, 'MS-7K-U-1P + MC100PRO-S1P/MS-7K-U-3P + MC100PRO-T3P' could support off grid scenarios.



2.1.2 Structure dimension

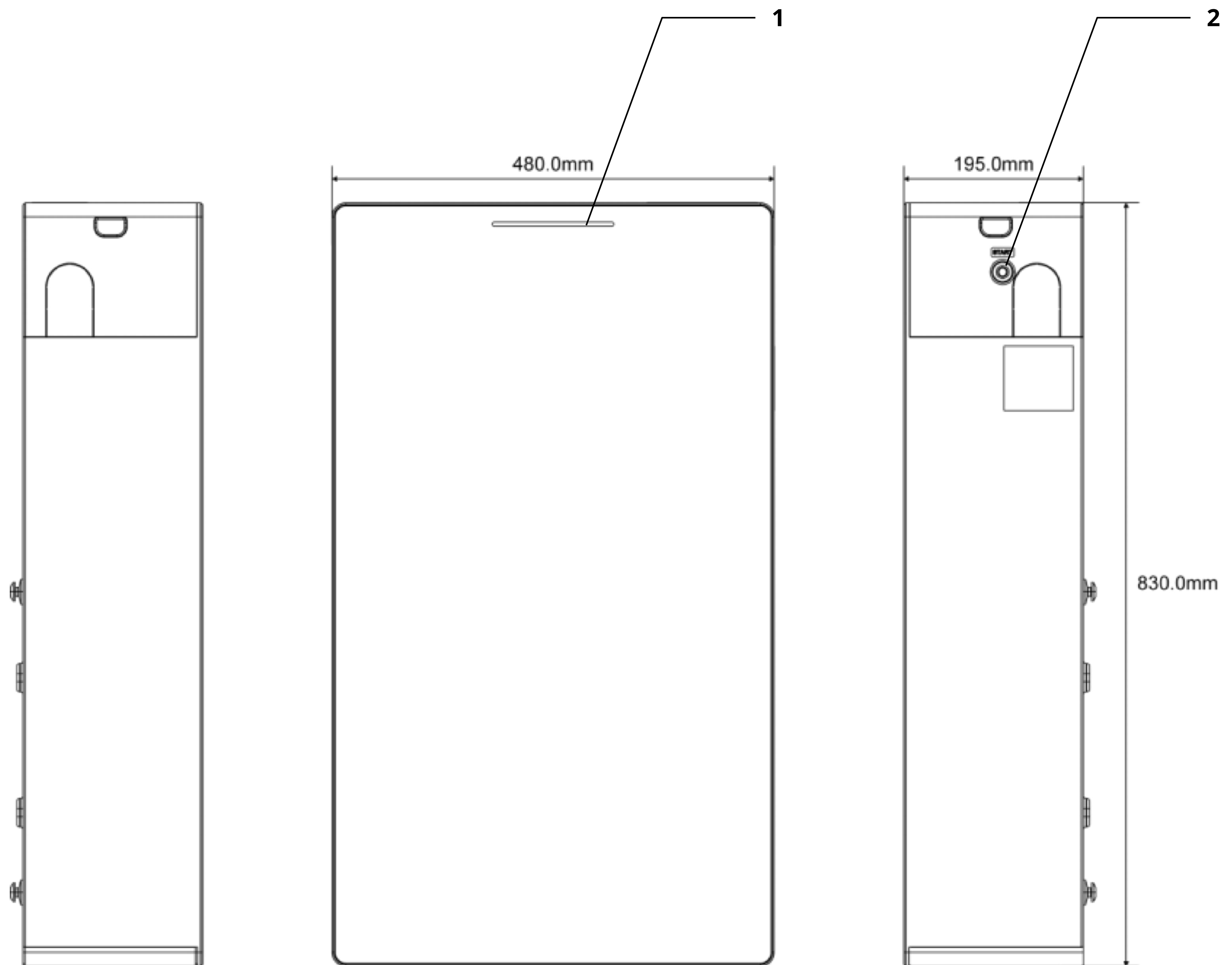

- 1. LED indicator
- 2. Reset button

2.1.3 Battery structure introduction

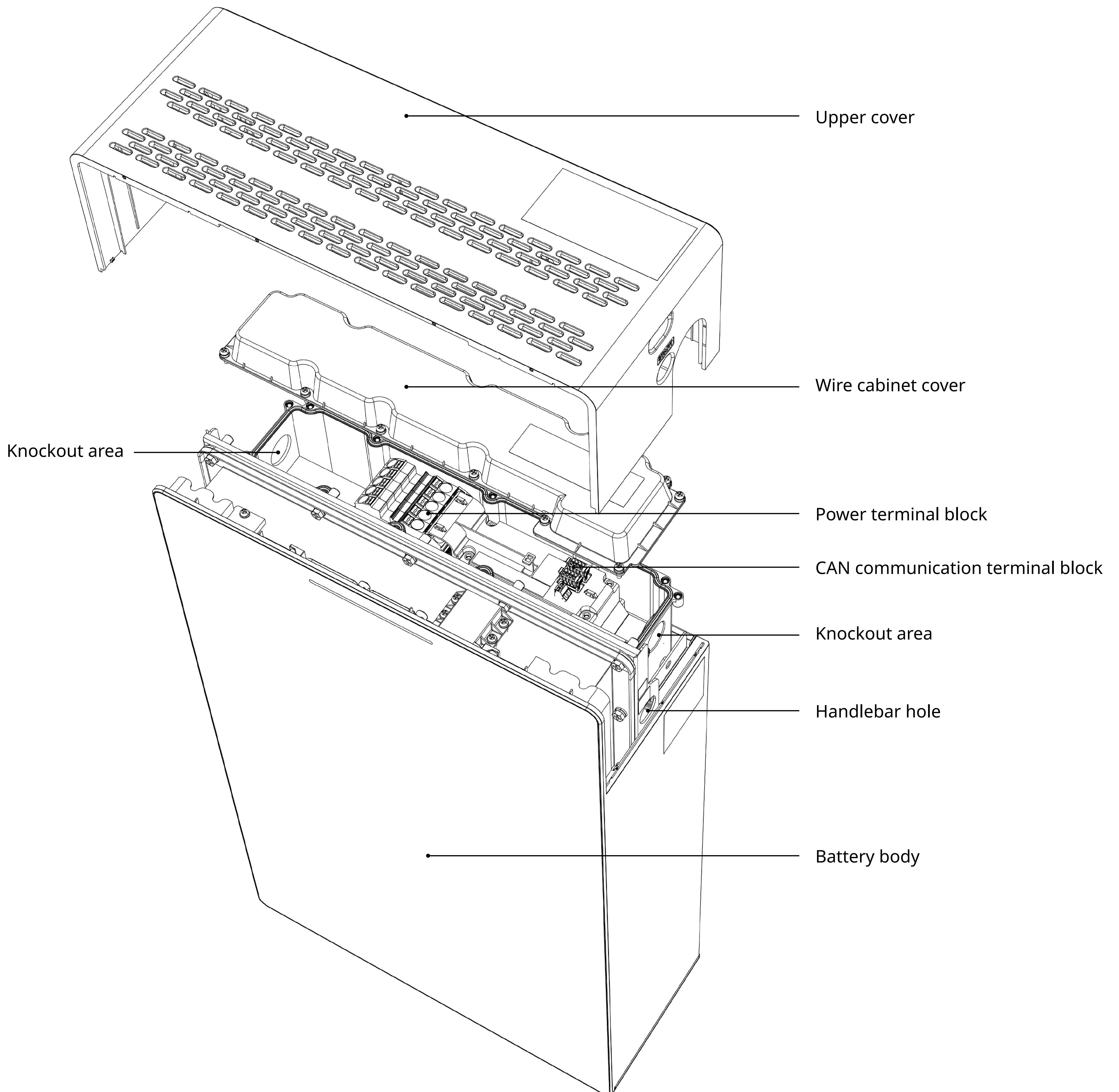

2.1.4 Label introduction

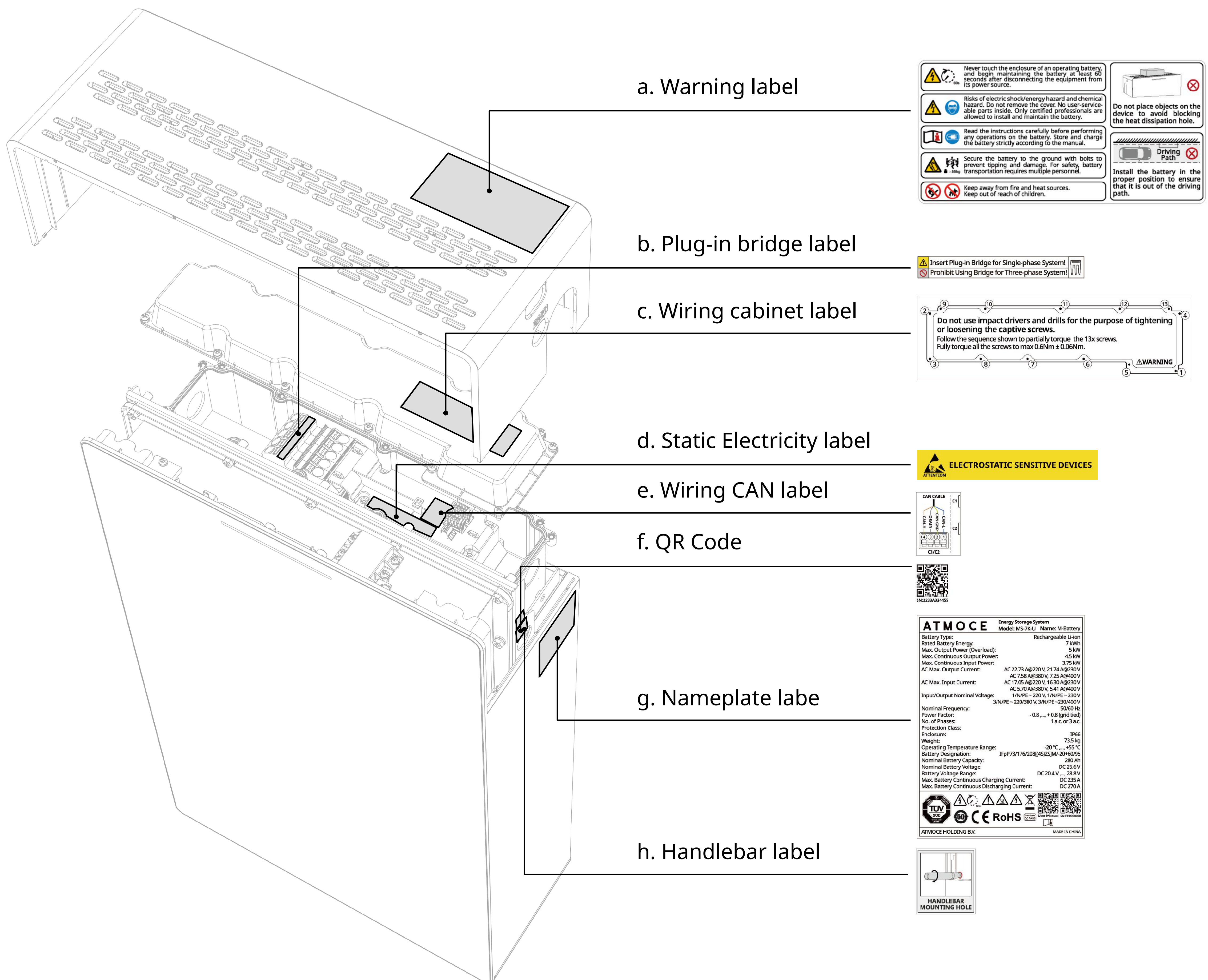

a. Warning label

	Never touch the enclosure of an operating battery, and begin maintaining the battery at least 60 seconds after disconnecting the equipment from its power source.		Do not place objects on the device to avoid blocking the heat dissipation hole.
	Risks of electric shock/energy hazard and chemical hazard. Do not remove the cover. No user-serviceable parts inside. Only certified professionals are allowed to install and maintain the battery.		Install the battery in the proper position to ensure that it is out of the driving path.
	Read the instructions carefully before performing any operations on the battery. Store and charge the battery strictly according to the manual.		
	Secure the battery to the ground with bolts to prevent tipping and damage. For safety, battery transportation requires multiple personnel.		
	Keep away from fire and heat sources. Keep out of reach of children.		

b. Plug-in bridge label

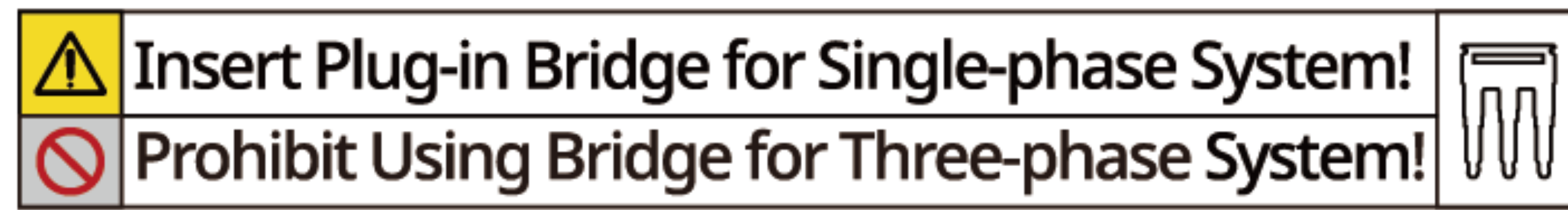

c. Wiring cabinet label

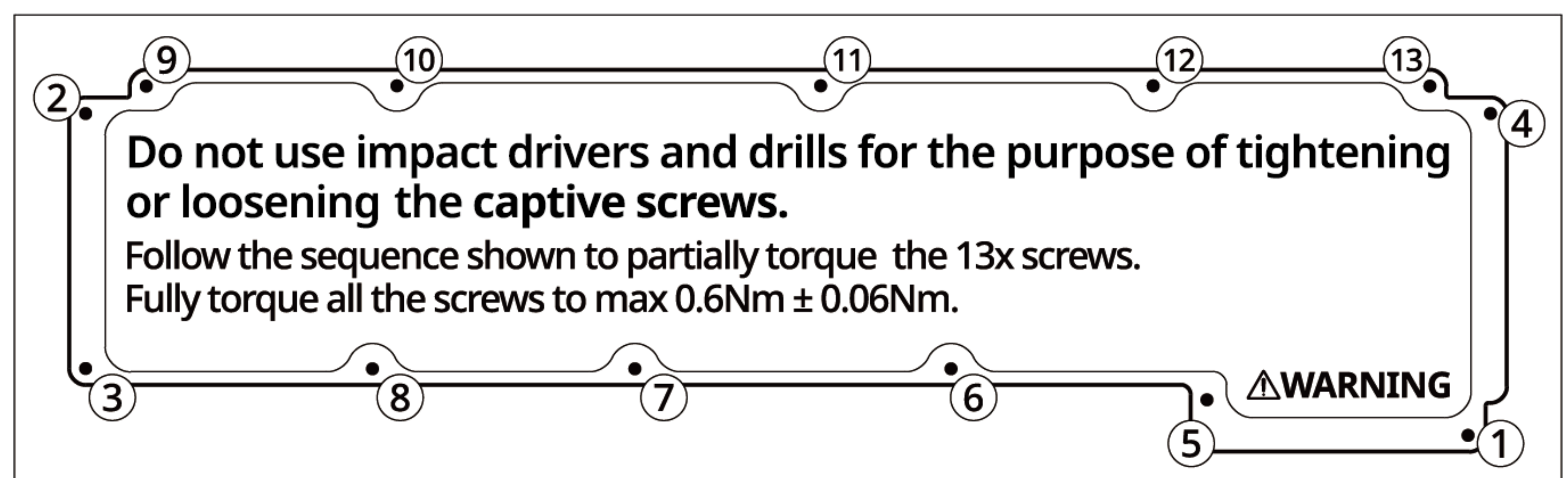

d. Static electricity label



e. Wiring CAN label

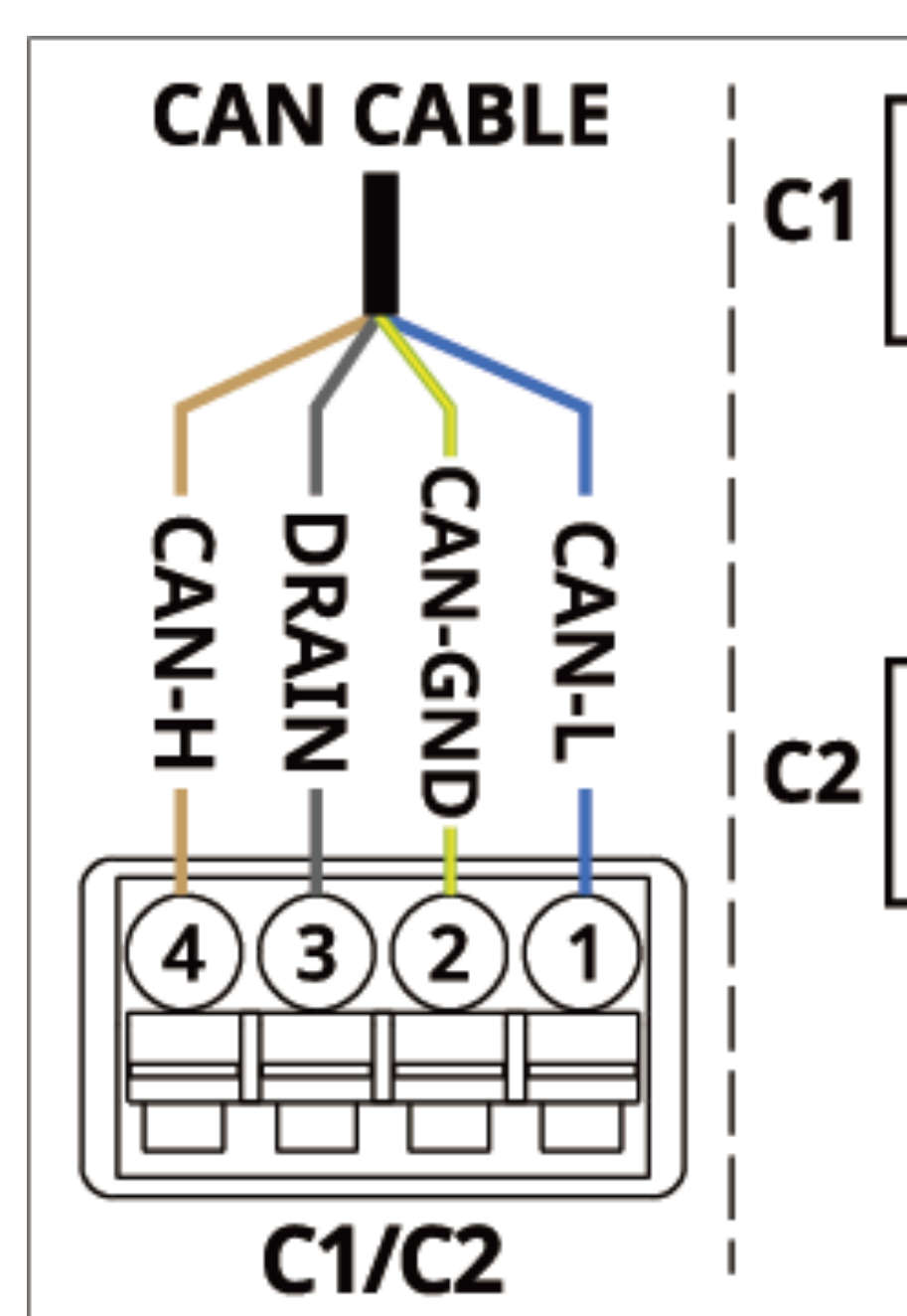

f. QR code



g. Nameplate

ATMOCE	
1-Phase Configuration:	
<input type="checkbox"/> Model: MS-7K-U-1P	
<input type="checkbox"/> Model: MS-7K-U-1P + MC100PRO-S1P (Support off-grid with MC100PRO-S1P)	
On-grid/off-grid parameters	
AC input/output nominal Voltage:	1/N/PE~230V
Nominal Frequency:	50 Hz
Max./Rated Input Apparent Power:	3.75 kVA
Max./Rated Input Current:	16.30 A
Max.Output Apparent Power:	5 kVA
Max. Output Current:	21.74 A
Rated Output Apparent Power:	4.5 kVA
Rated Output Current:	19.57 A
3-Phase Configuration:	
<input type="checkbox"/> Model: MS-7K-U-3P	
<input type="checkbox"/> Model: MS-7K-U-3P + MC100PRO-T3P (Support off-grid with MC100PRO-T3P)	
On-grid/off-grid parameters	
AC input/output nominal Voltage:	3/N/PE~230/400V
Nominal Frequency:	50 Hz
Max./Rated Input Apparent Power:	3.75 kVA
Max./Rated Input Current:	5.41 A
Max.Output Apparent Power:	5 kVA
Max. Output Current:	7.25 A
Rated Output Apparent Power:	4.5 kVA
Rated Output Current:	6.52 A
ATMOCE HOLDING B.V.	MADE IN CHINA

ATMOCE Energy Storage System	
Model: MS-7K-U	Name: M-ELV Battery
Battery Type:	Rechargeable Li-ion
Rated Battery Energy:	7 kWh
Max. Output Apparent Power:	5 kVA
Rated Output Apparent Power:	4.5 kVA
Max./Rated Input Apparent Power:	3.75 kVA
AC Max. Output Current:	AC 22.73 A@220 V, 21.74 A@230 V AC 7.58 A@380 V, 7.25 A@400 V
AC Rated Output Current:	AC 20.45 A@220 V, 19.57 A@230 V AC 6.82 A@380 V, 6.52 A@400 V
AC Max./Rated Input Current:	AC 17.05 A@220 V, 16.30 A@230 V AC 5.70 A@380 V, 5.41 A@400 V
Input/Output Nominal Voltage:	1/N/PE ~ 220 V, 1/N/PE ~ 230 V 3/N/PE ~ 220/380 V, 3/N/PE ~ 230/400 V
Nominal Frequency:	50/60 Hz
Power Factor:	- 0.8 ,,,, + 0.8 (grid tied)
No. of Phases:	1 a.c. or 3 a.c.
Protection Class:	I
Over Voltage Category:	III
Inverter Topology:	Isolated
Enclosure:	IP66
Weight:	73.5 kg
Operating Temperature Range:	-20 °C ,,,, +55 °C
Battery Designation:	IFpP73/176/208[(4S)2S]M/-20+60/95
Nominal Battery Capacity:	280 Ah
Nominal Battery Voltage:	DC 25.6 V
Battery Voltage Range:	DC 20.4 V ,,,, 28.8 V
Max. Battery Continuous Charging Current:	DC 235 A
Max. Battery Continuous Discharging Current:	DC 270 A
ATMOCE HOLDING B.V.	MADE IN CHINA

Nameplate Label Instruction

Lable	Description
	The product has passed CE related certification.
	Waste electrical and electronic equipment (WEEE), which cannot be treated as household waste and should be returned to ATMOCE or disposed of in accordance with local regulations.
	Restriction of Hazardous Substances (ROHS)-compliant.
	Please read the user manual before using the equipment.
	Delayed discharge. Wait 60 seconds for the unit to fully discharge after it is powered off.
	Risk of burn. Do not touch the enclosure of the microinverter, as its temperature will become high during operation.
	Risk of electric shock. Switch off the power to the circuit breaker(s) you're working with.
	Exceeding this period may pollute the environment
	Caution.

h. Handlebar label

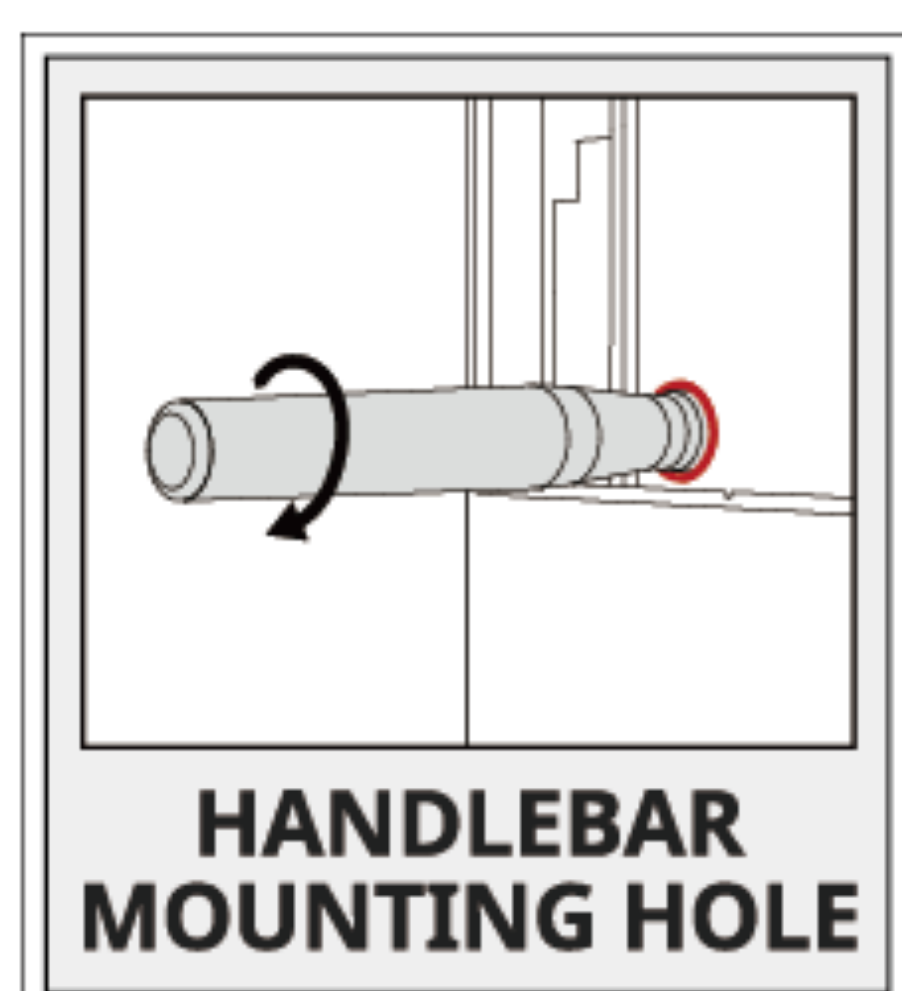

Storage Requirements

If the product is not to be used and installed immediately, it must be stored in accordance with the following requirements:

- Do not remove the outer packaging of the product.
- The storage temperature should be maintained within $-20\text{ }^{\circ}\text{C}$ to $+55\text{ }^{\circ}\text{C}$.
- The relative humidity should be maintained between 4% RH and 100% RH.
- Store the product in a clean and dry place, away from dust and moisture.
- Stack no more than 7 layers high. When stacking, please be careful when placing the packaging box to avoid personal injury or equipment damage caused by equipment tipping over.
- Regular inspections are required during storage (once every three months recommended). If the product has been placed in storage for two years or longer, it must be inspected and tested by qualified personnel before use.
- Regular recharging are required during storage as the table below.

Storage temperature	Storage time
$-20^{\circ}\text{C} < T \leq 25^{\circ}\text{C}$	15 months
$25^{\circ}\text{C} < T \leq 35^{\circ}\text{C}$	9 months
$35^{\circ}\text{C} < T \leq 45^{\circ}\text{C}$	6 months
$45^{\circ}\text{C} < T \leq 55^{\circ}\text{C}$	3 months

NOTE:

- If it is within the storage time, the battery does not need to be recharged.
- If it has exceeded the storage time, the battery should be recharged as soon as possible.
- The maximum number of recharging is 3. If the maximum number of times is exceeded, it is recommended to discard the battery.
- The battery power must be recharged to 30% SOC.

M-ELV Battery Installation

4.1 Pre-installation Requirements

4.1.1 Grid requirements

ATMOCE battery should connect to a single-phase or a three-phase grid. Measure AC line voltages at the point of connection to confirm that they are within the ranges.

Phase setup	Voltage range	
Single-phase	L to N	176 to 276 Vac
Three-phase	L1, L2, L3 to N	176 to 276 Vac

NOTE:

- Miniature Circuit Breaker (MCB) is used for protection. The MCB specification must meet the following requirements: IEC 60947-2, trip curve C: - characteristic of short-circuit protective device each pole, rated 63A, for single-phase system and three-phase system at least 10 kA fault current interrupting capacity at 230V/pole.

4.1.2. Cable requirements

To properly set up the system, it is necessary to select the appropriate cables. The table below shows the recommended cable requirements.

Function	Recommendation
Power cable	4 to 10 mm ² , 3-core @ single-phase 2.5 to 10 mm ² , 5-core @ three-phase
CAN COM cable	0.25 to 0.75 mm ² , 3-core + drain

NOTE:

- When connecting the cables to the M-Battery, you must cover the cable ends by using the proper cold-press terminal provided in the package.
- When stripping the cable, remove approximately 12 mm of the insulation layer from the power cable and 8mm of insulation layer from the communication cable.
- Installer shall avoid the wires and pipes behind the wall when they drill the hole on the wall.

4.1.3 Prepare the Tools and Materials

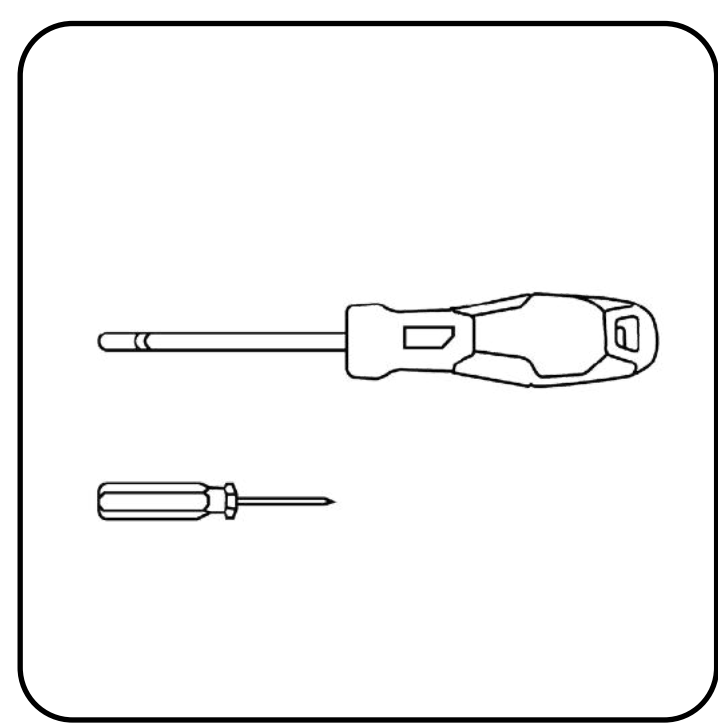

Screwdriver(M8)

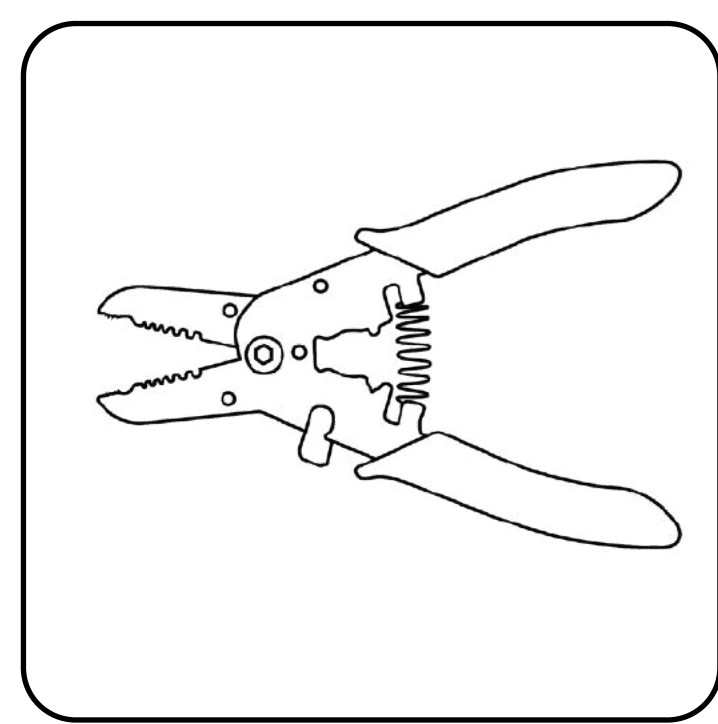

Wire stripper

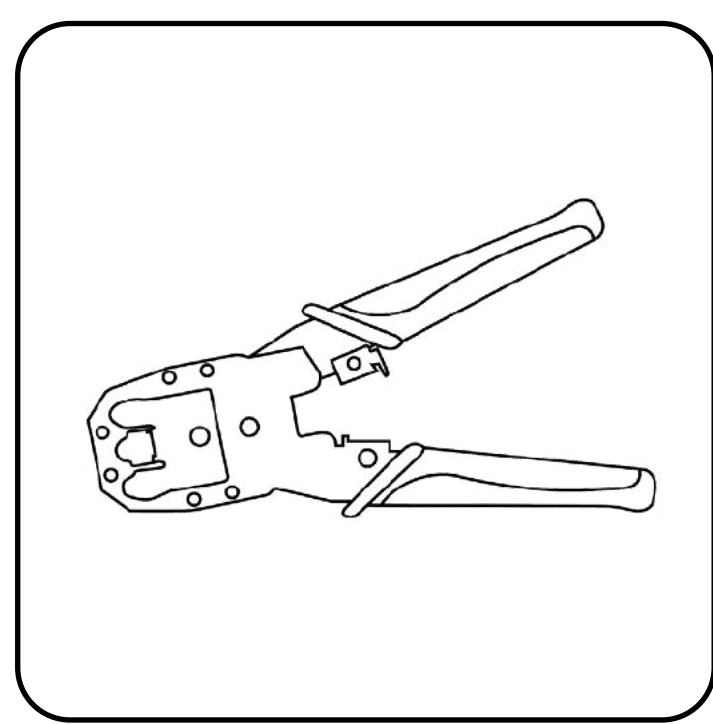

Power line crimper

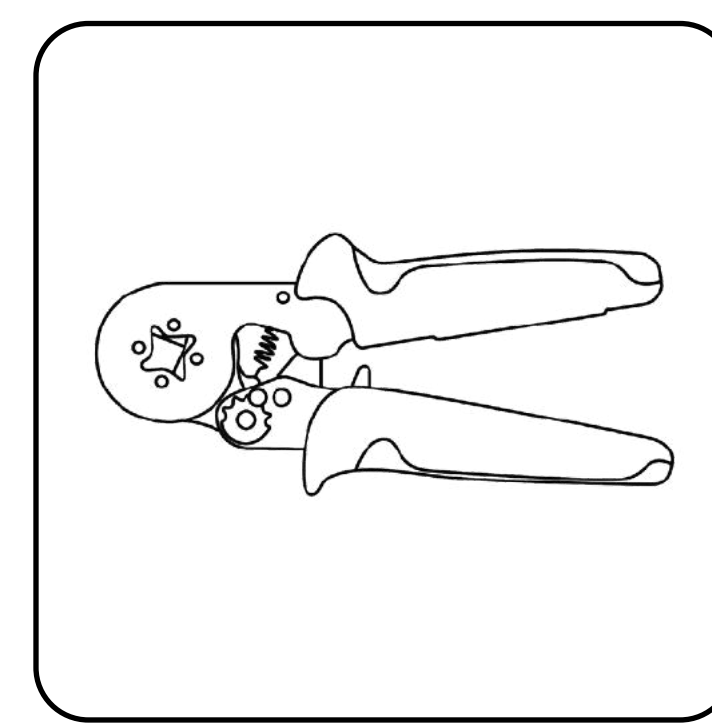

Communication line crimper

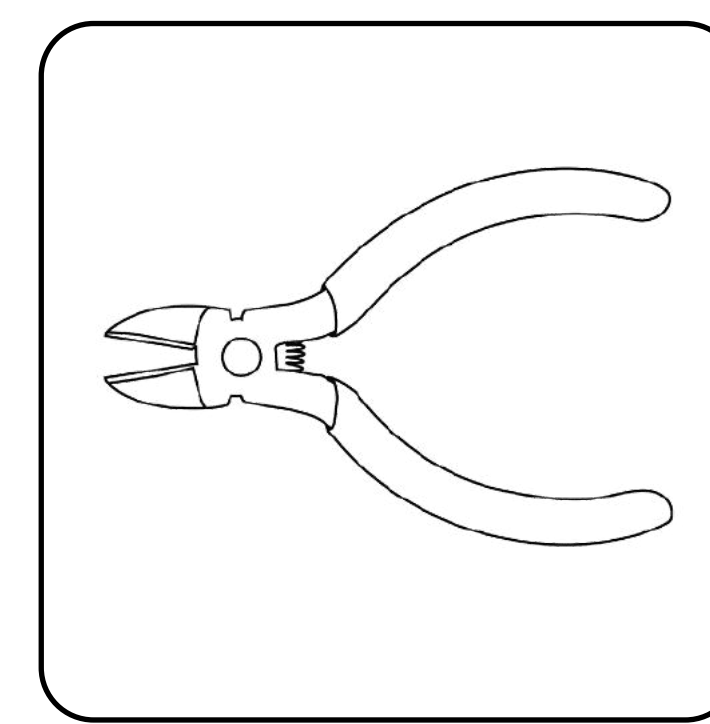

Diagonal cutter

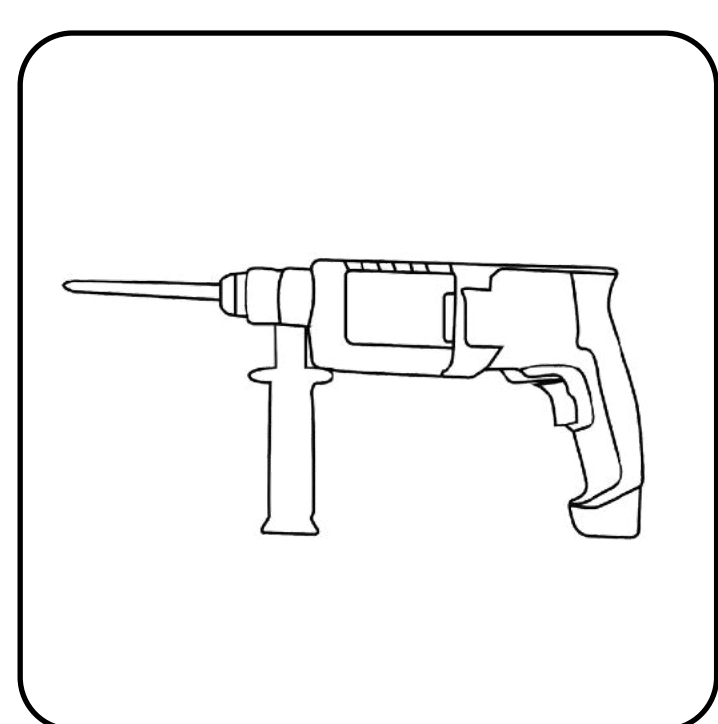

Drill



Hammer

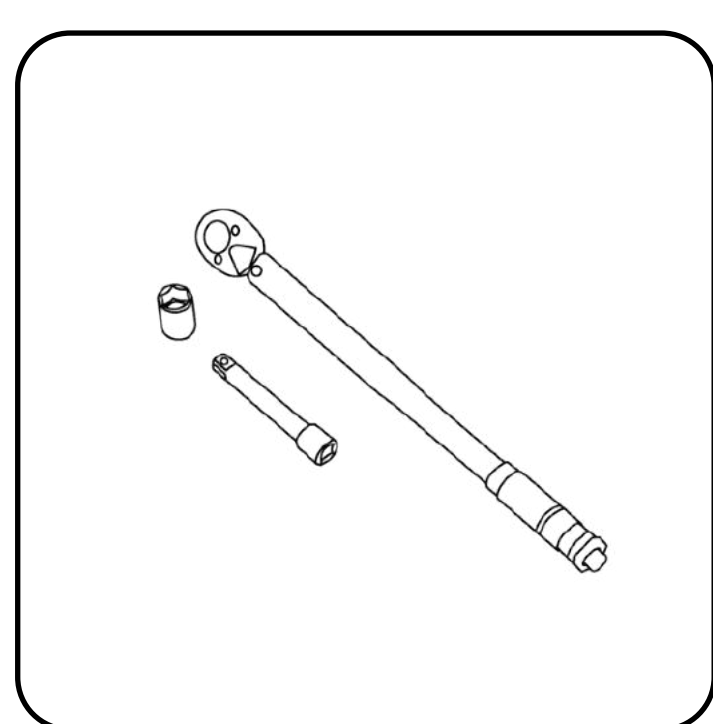

Torque wrench

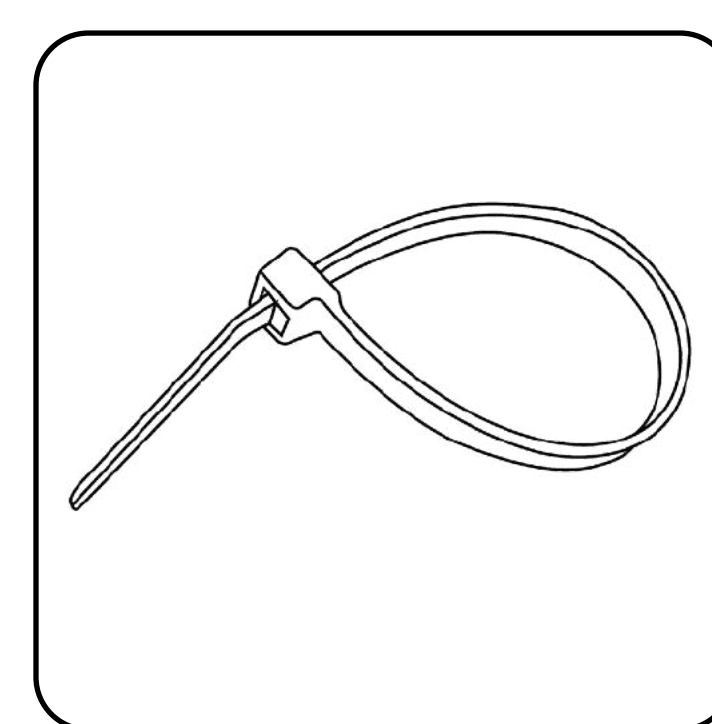

Tie wrap



Multimeter

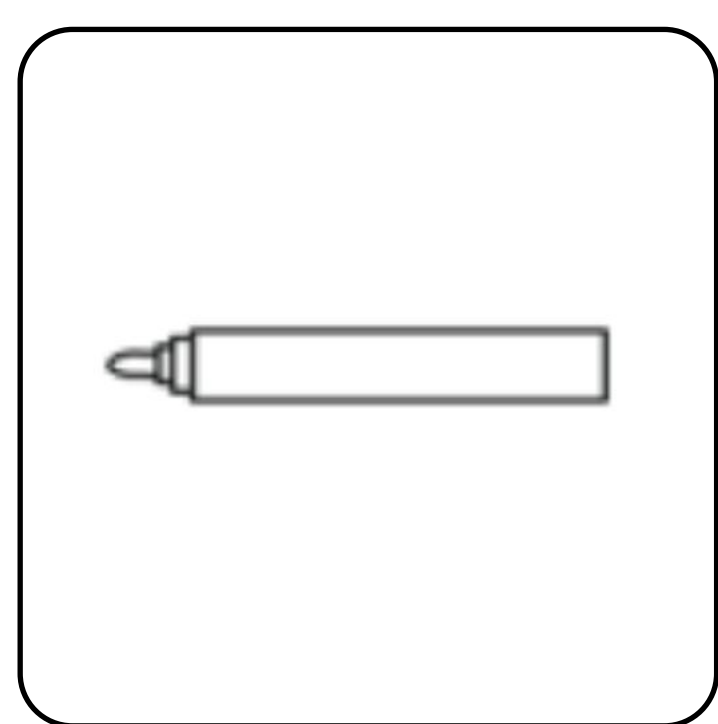

Marking pen

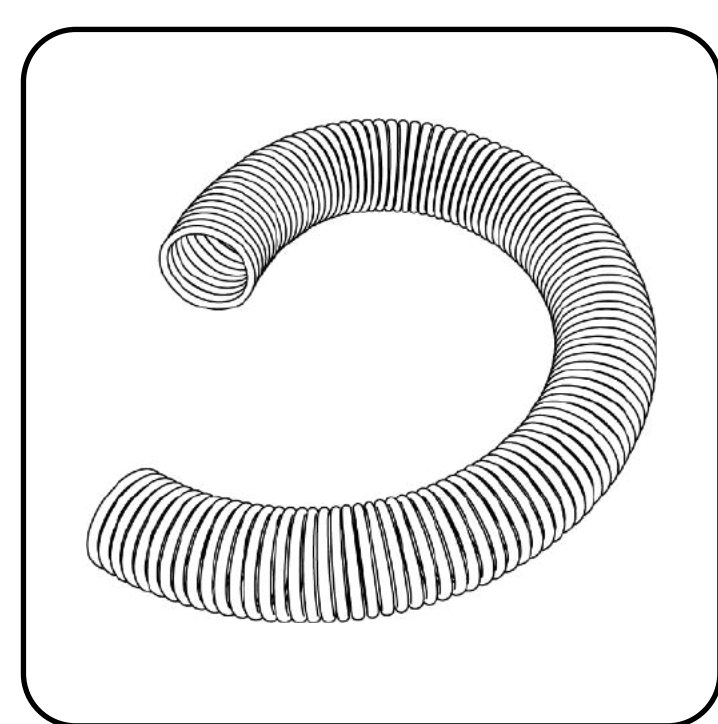

Corrugated protective pipe

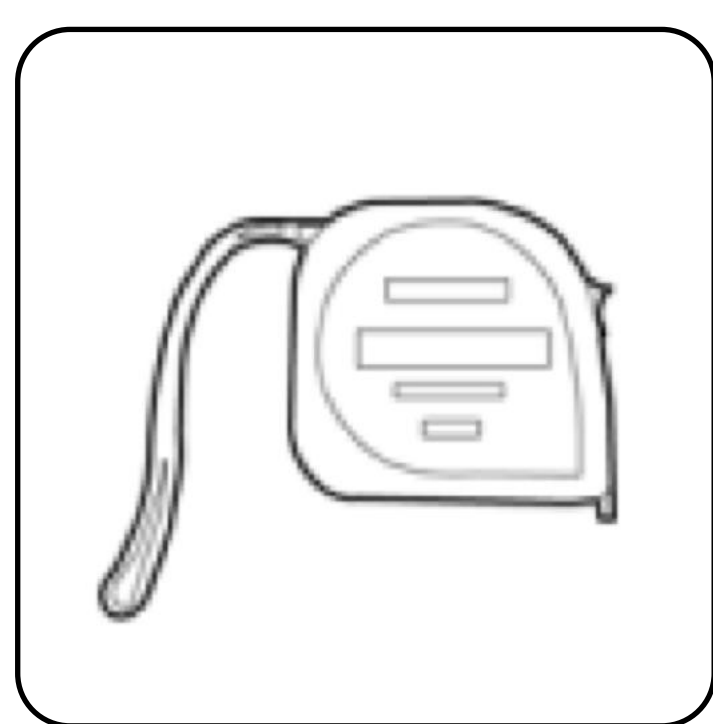

Tape measure

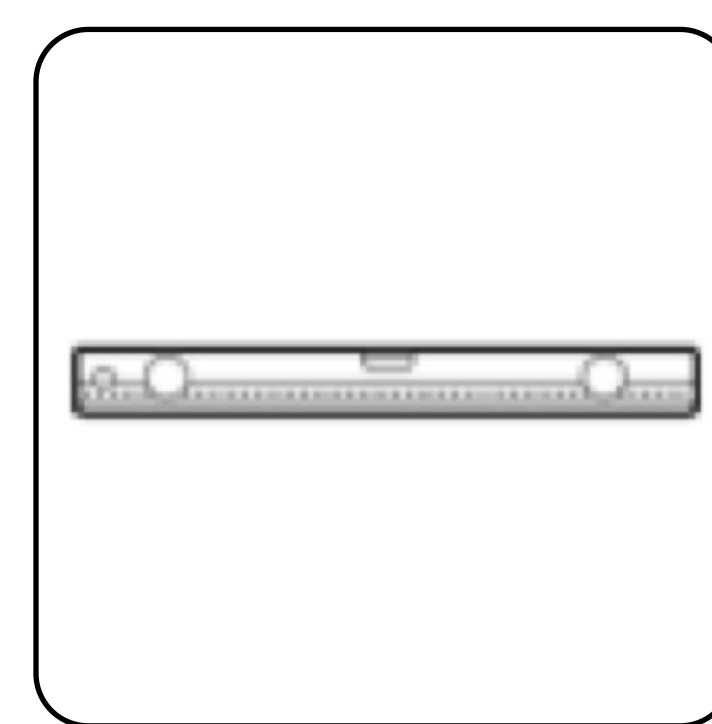

Spirit level

4.1.4 Prepare the Safety Equipment

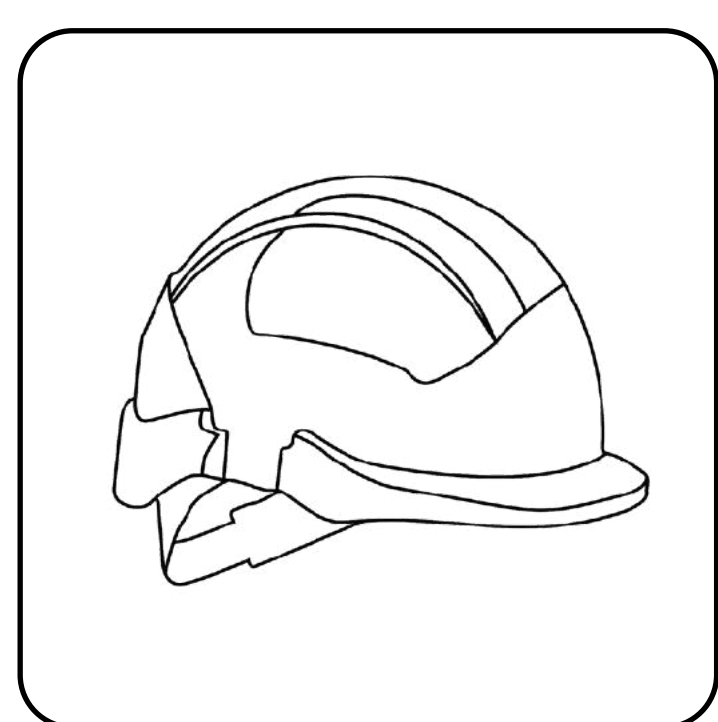

Safety helmet

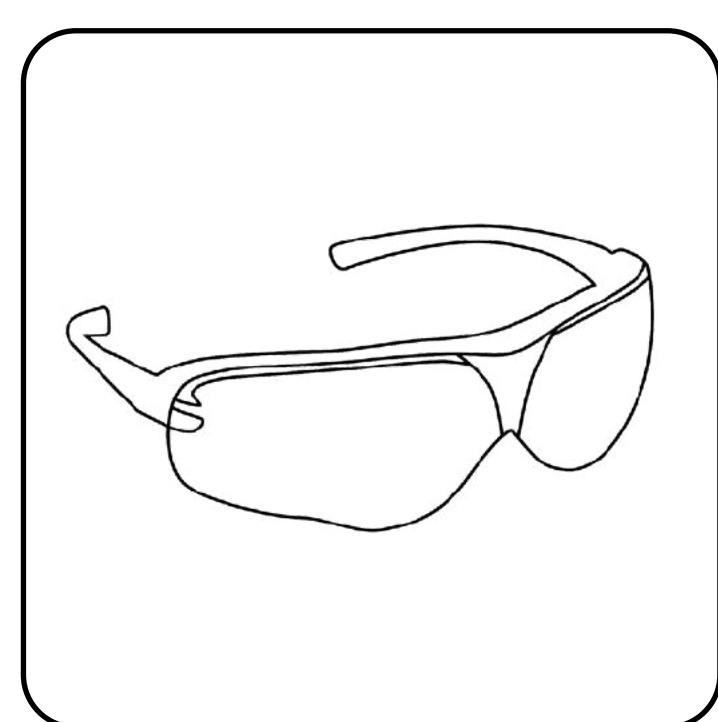

Protective goggles

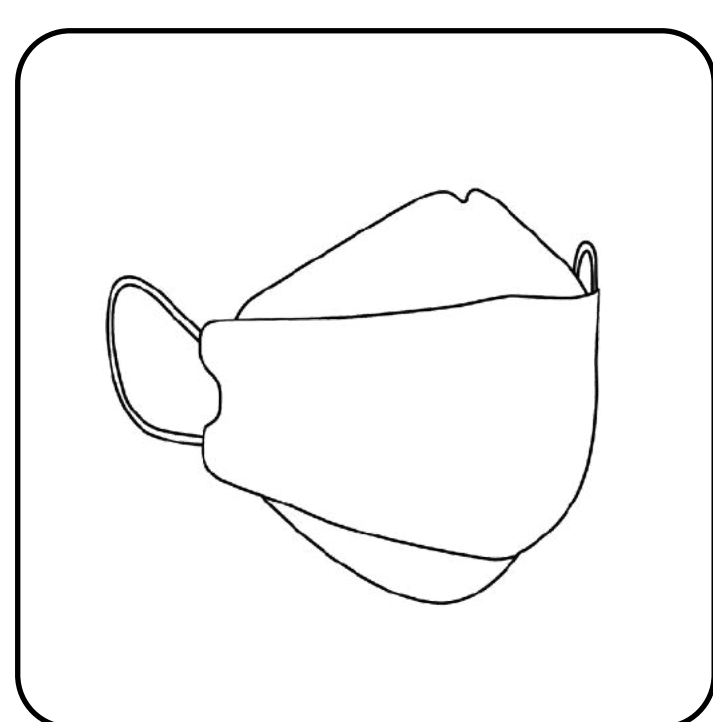

Mask

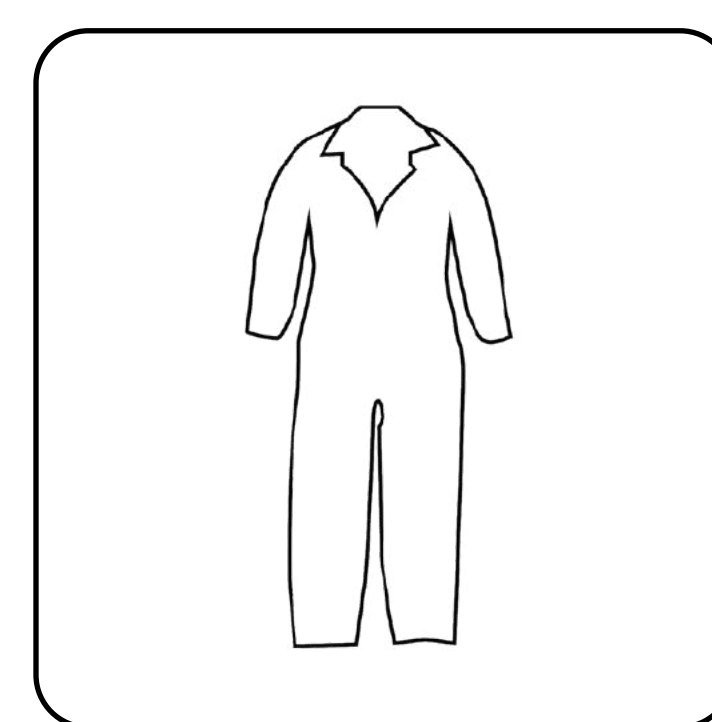

Safety clothing

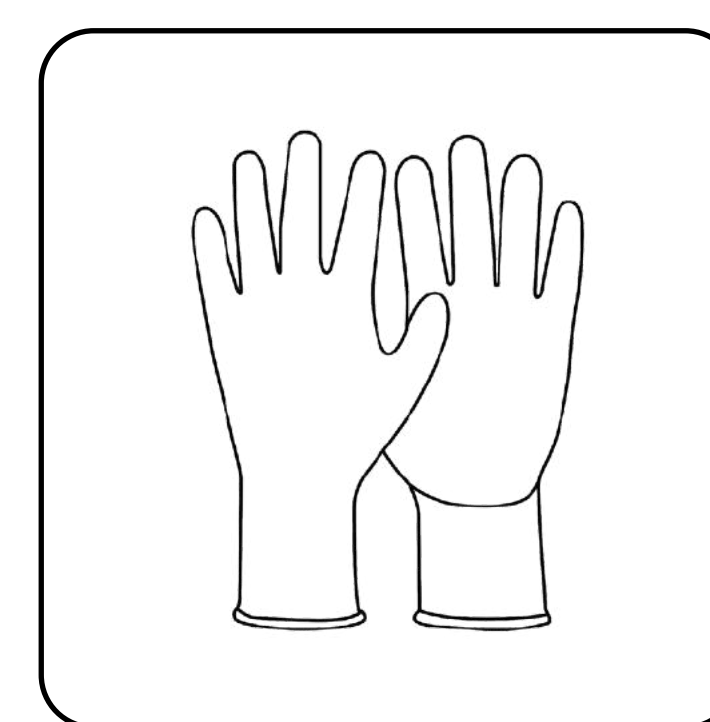

Safety gloves

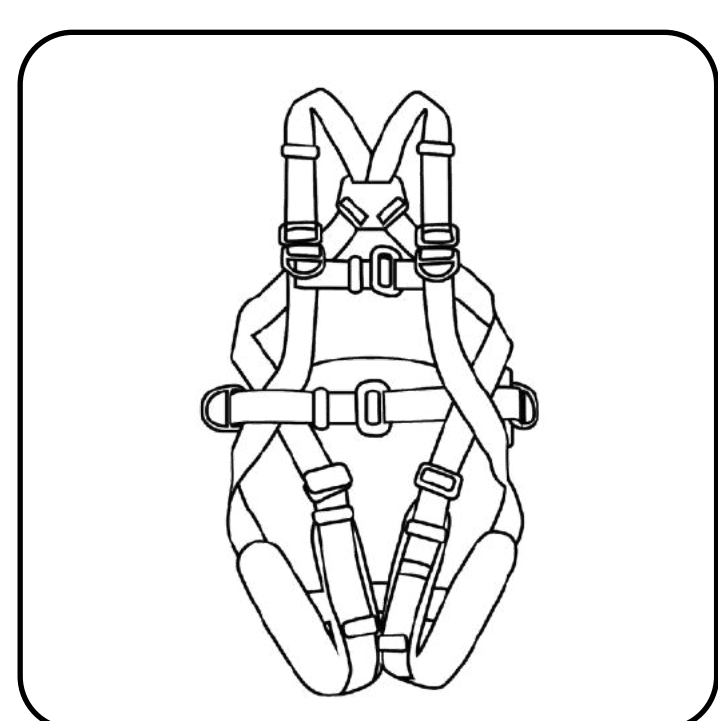

Safety belt



Safety shoes

4.1.5 Download the Atmozen App

Download the latest version of the Atmozen app. Open and log in to your account. You can track the progress of system installation with this app.



4.1.6. Recommended installation environment and space

a. The installation environment should be:



Install indoors



Install outdoors



Install under 3000m

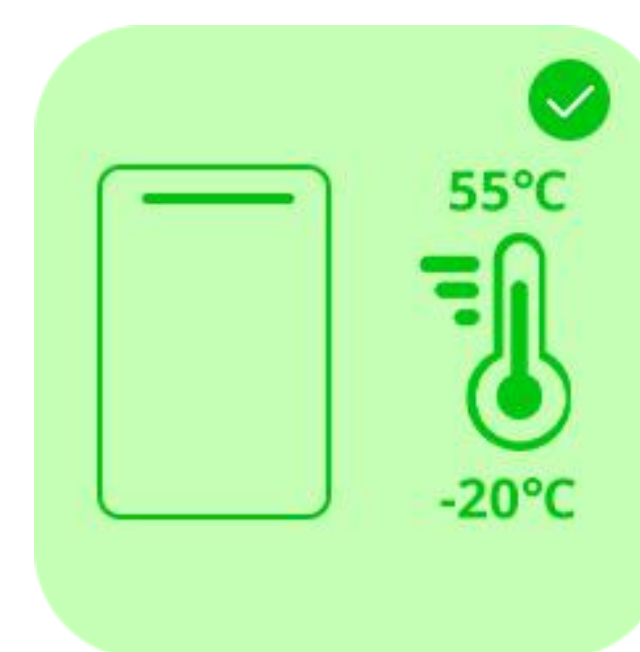

Install from -20 to 55

b. The installation environment should not be:



No sunlight directly



No flame



No crowded areas



No immersion > 50cm

NOTE:

- Storage Temperature: -20 to 55°C
- Operating Temperature: Ambient Range: -20 to 55°C; Optimal Range: 0 to 30°C
- Operating Humidity: 4 to 100% RH (condensing permitted)

c. The installation space should meet the following conditions.

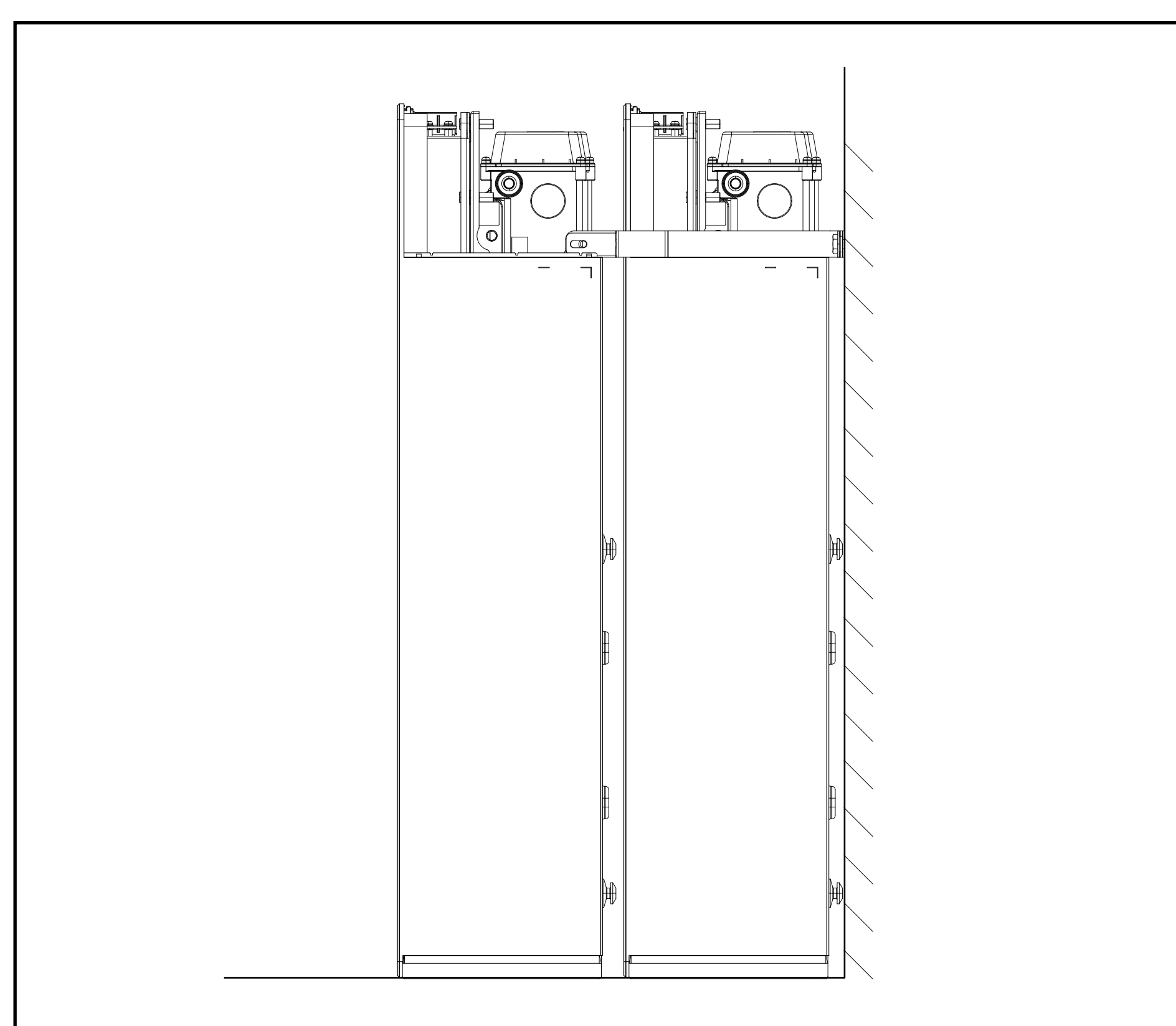

NOTE:

- When paralleling two batteries front and back, the minimum distance between them should be approximately 2 cm.
- There is no mandatory distance requirement on both the left/right of the battery.
- The minimum distance above and below the battery shall be no less than 15 cm.
- The maximum length of provided CAN cable is 3m, if CAN cable is prepared by the installer, the maximum extension can be up to 50m.
- The maximum parallel connection distance can reach 50m.

NOTE:

- Do not install in a completely enclosed space; the installation area must be well-ventilated.
- The battery shall be installed in a well-ventilated area, such as an outdoor location or a garage with natural airflow.
- Installation in enclosed or unventilated spaces (e.g., sealed cabinets, closets, or small confined rooms) is not permitted unless adequate mechanical ventilation is provided.
- Adequate clearance shall be maintained around the unit to ensure effective heat dissipation and airflow.

4.2 Take out the M-Battery

a. Check the accessories in the box, it contains the following items.

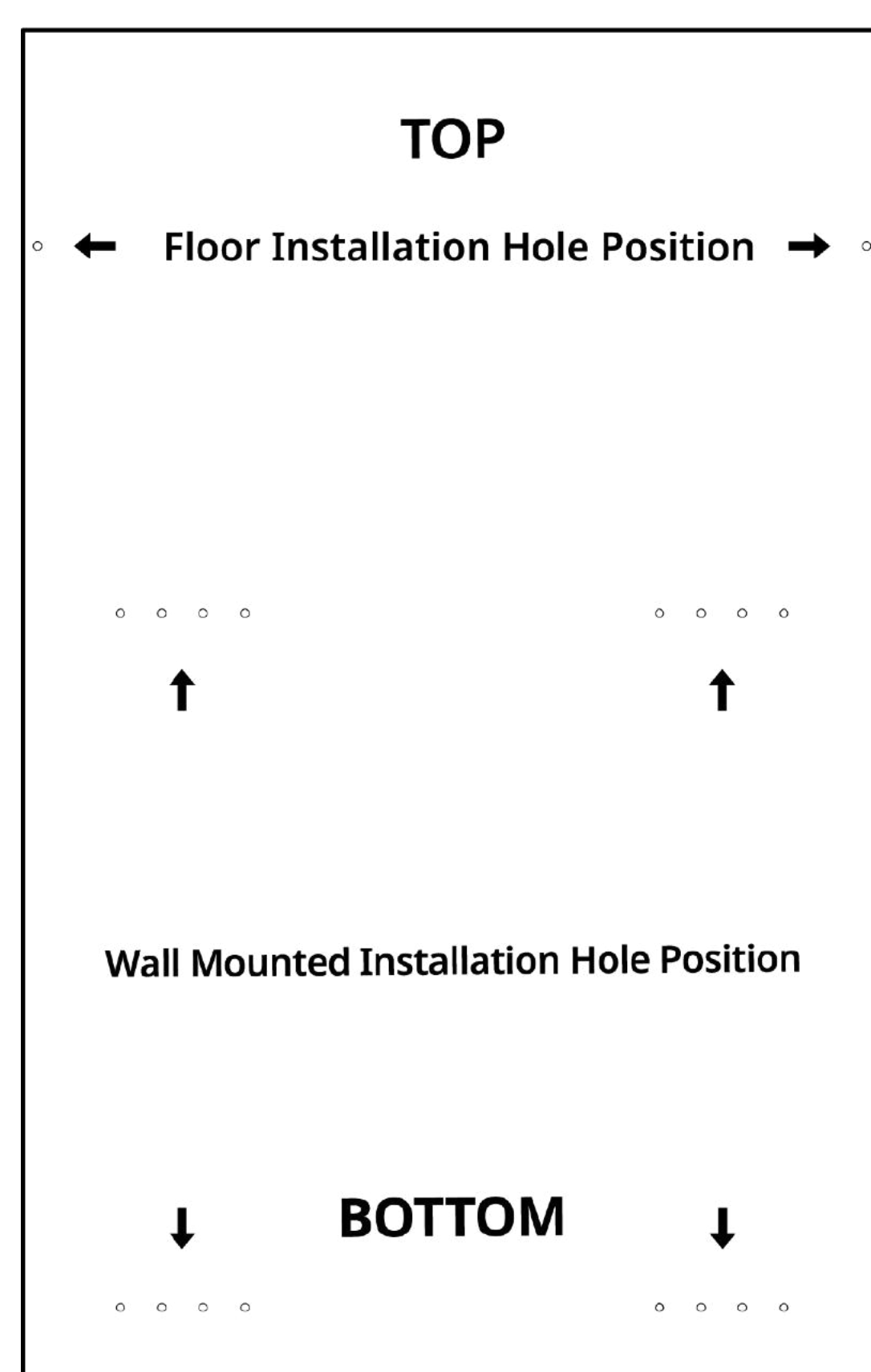

Marking plate

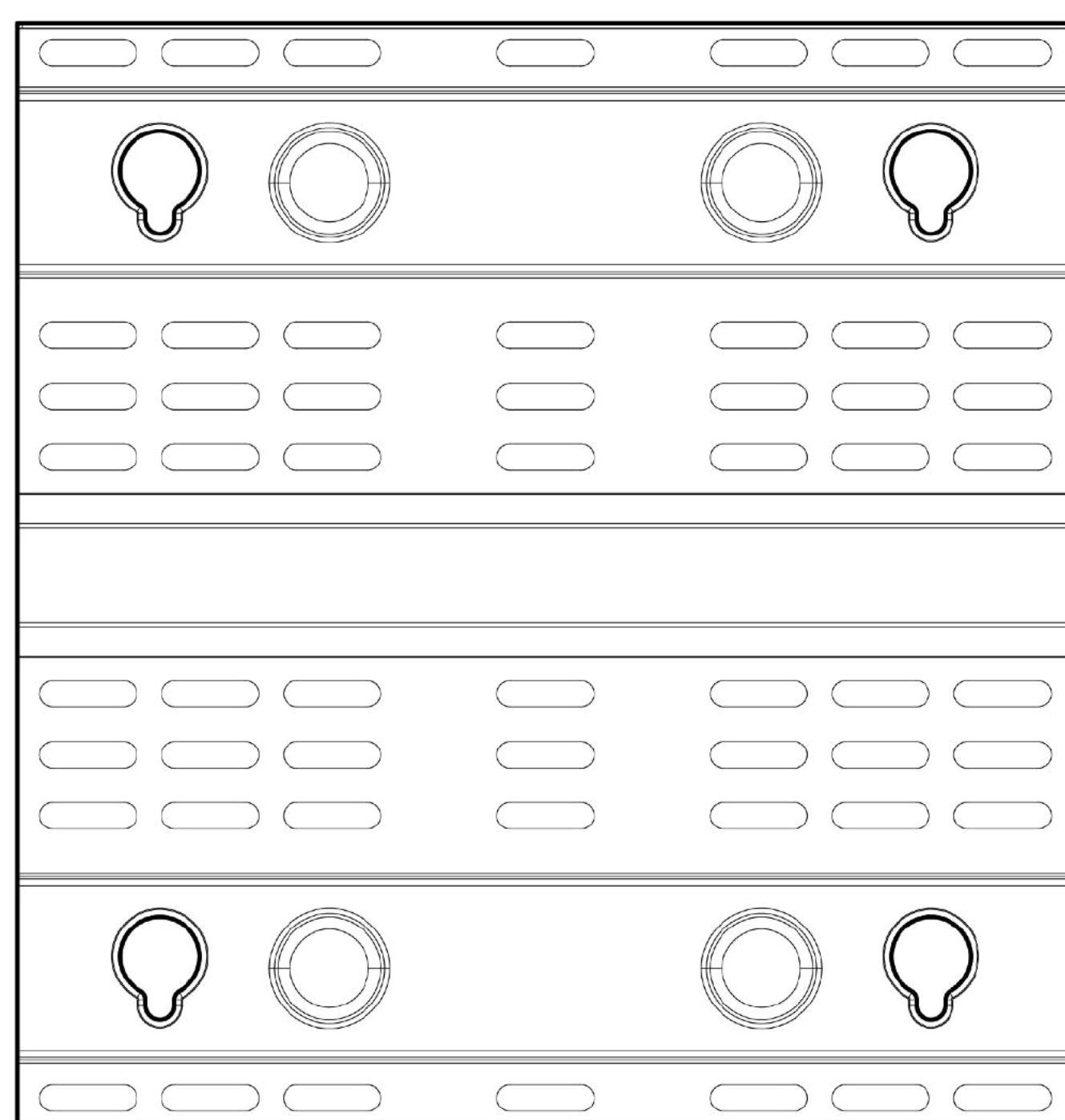

Mounting plate

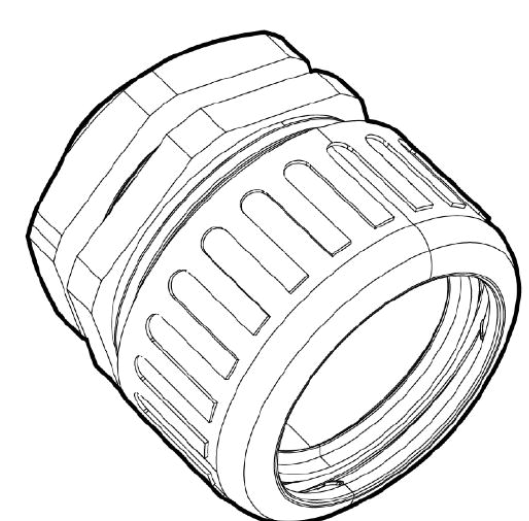

Waterproof glands

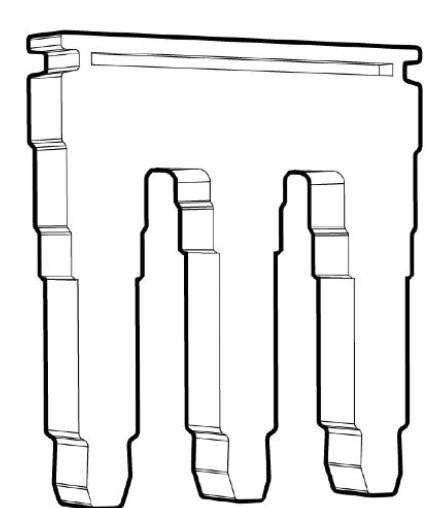

Plug-in bridge

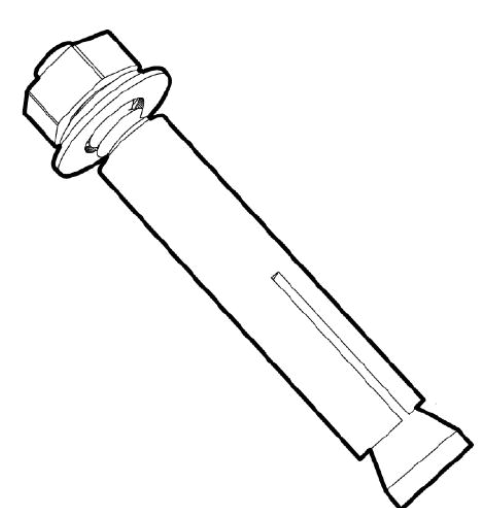

Expansion screws

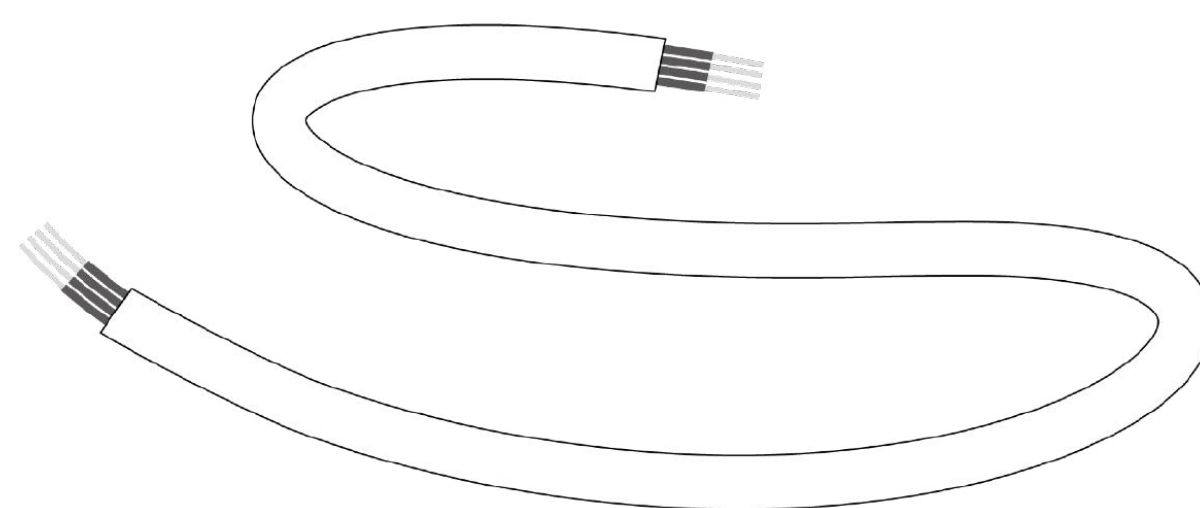

3m CAN COM cable

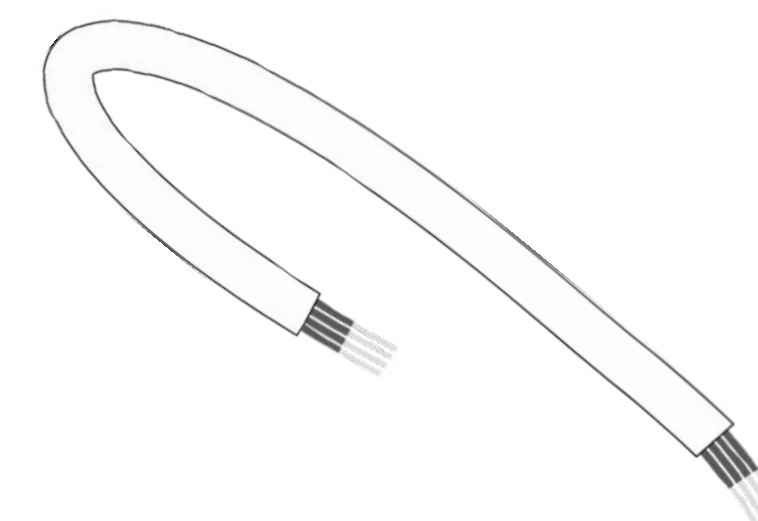

1.5m CAN COM cable

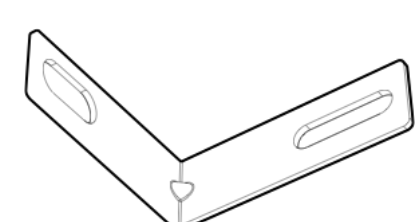

Mounting lug

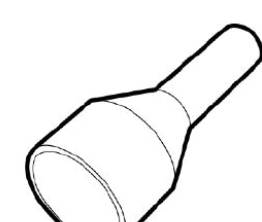

Cold-press terminals



Screws

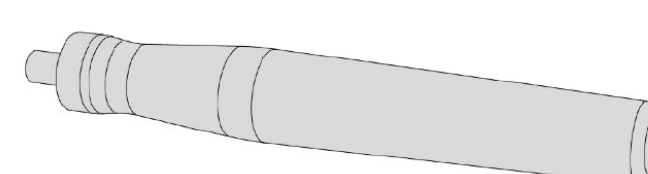

Handlebar

b. After unboxing, remove the upper cover of the M-Battery.

c. Take out the handlebars and insert them into the holes on the both sides of the battery.

d. Remove the battery out of the box.

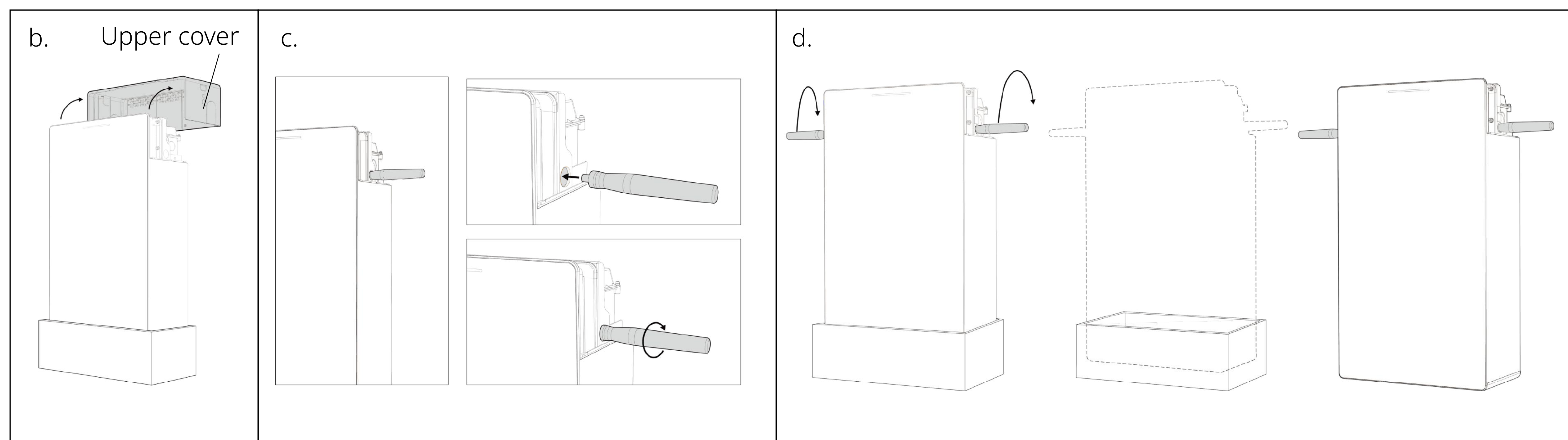

4.3 Mount the M-Battery

For floor installation, the floor must be level, otherwise wall mounting is recommended.

4.3.1 Mount on the floor

- Take out the marking plate and place it on the wall. Use the spirit level to check that the plate is level, then make the marks.
- Drill at the two marks by using an electric drill with a bit ($\Phi 14$).

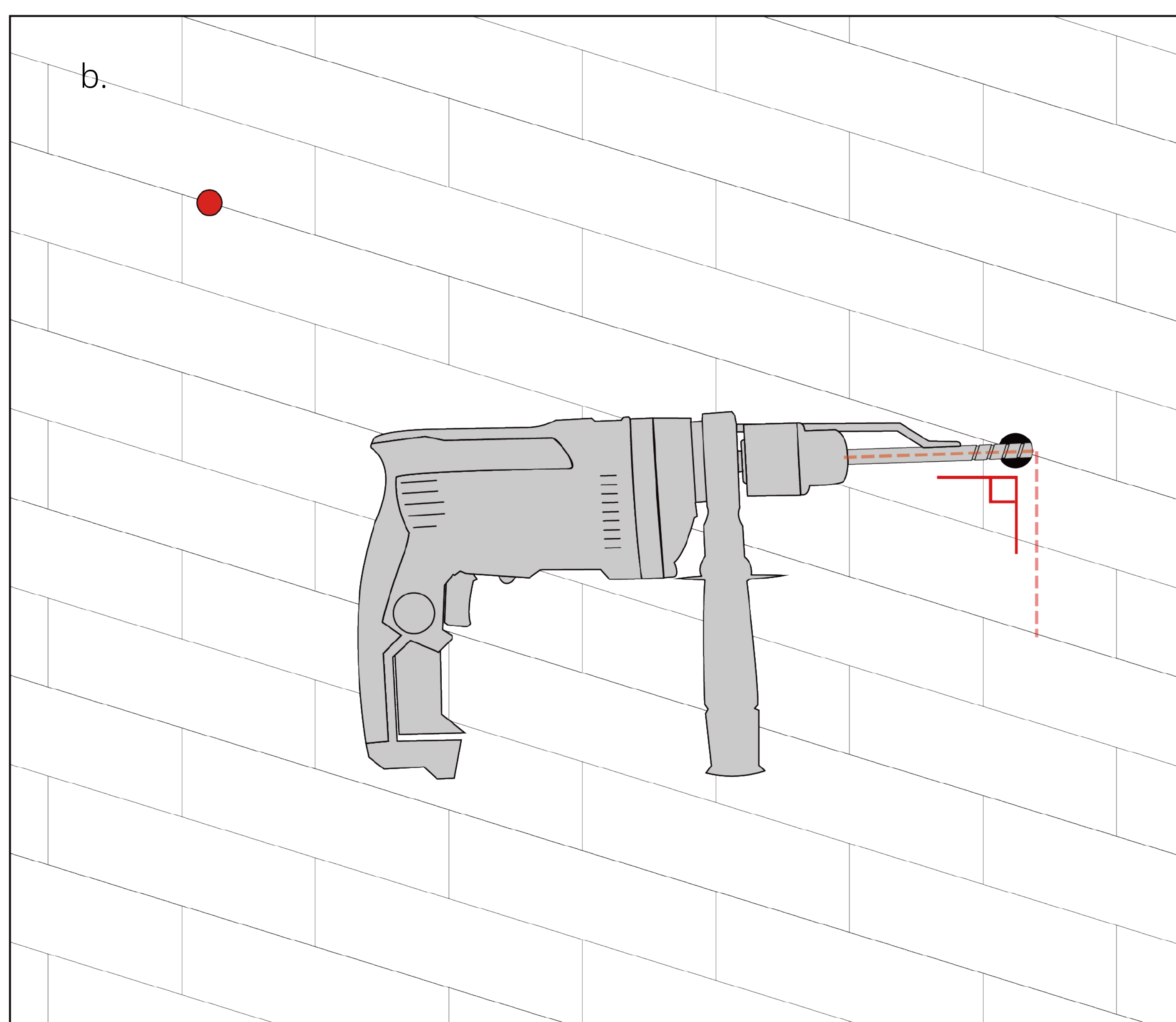
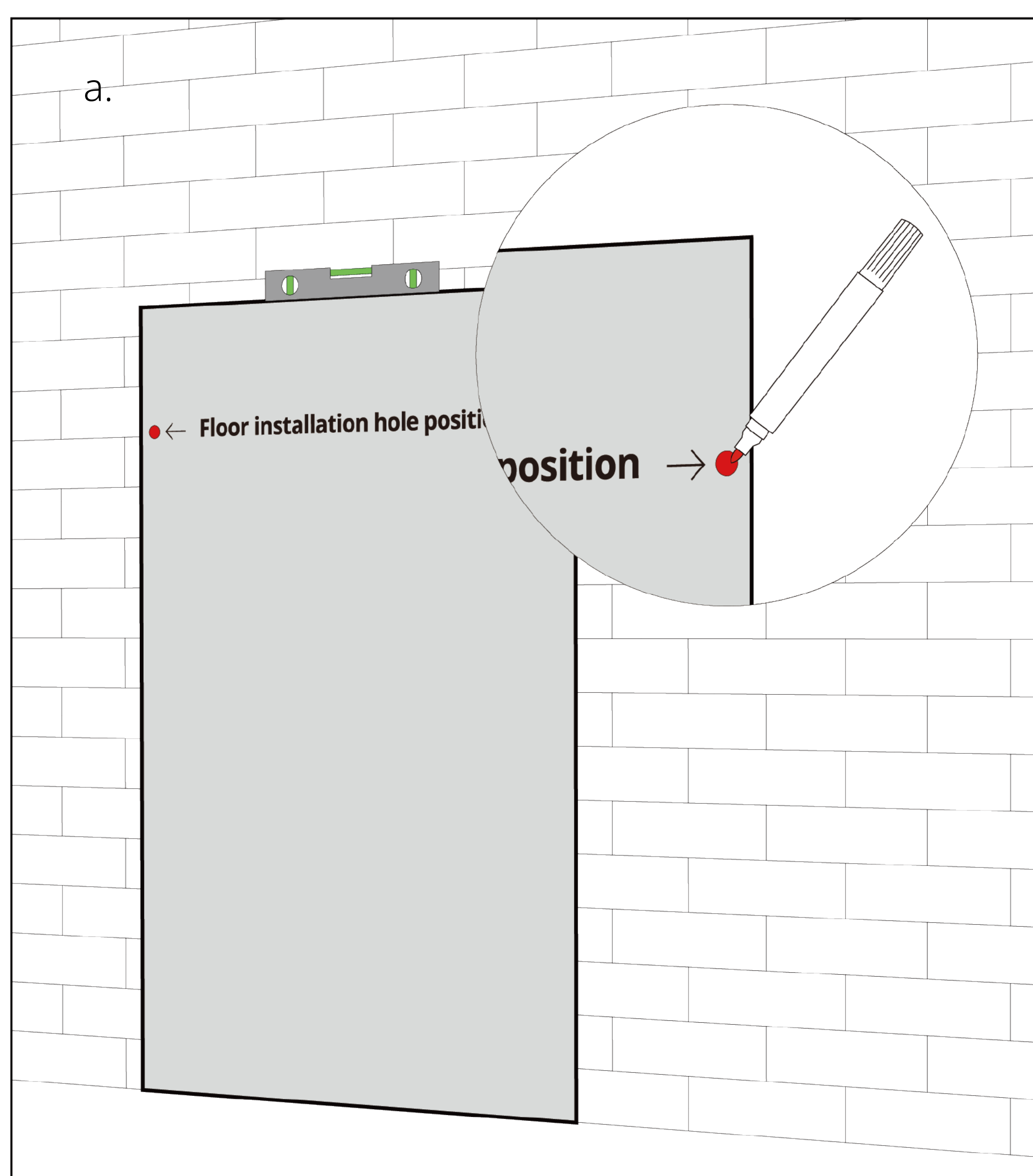

- Take out the expansion screws and align them with the holes. Knock them into the wall with a hammer and tighten the screws with a torque of 9–14 N·m, then loosen the screws.

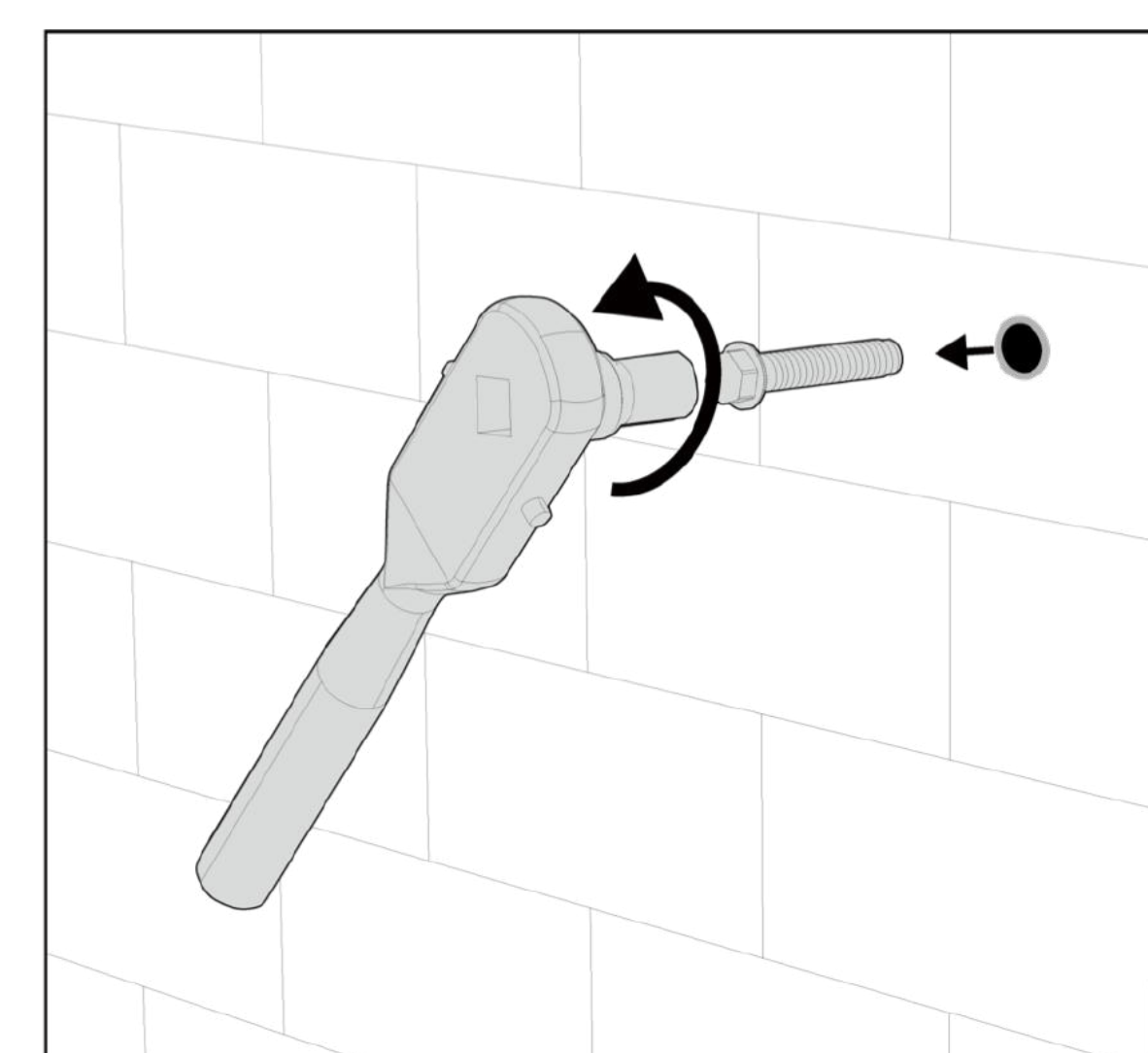
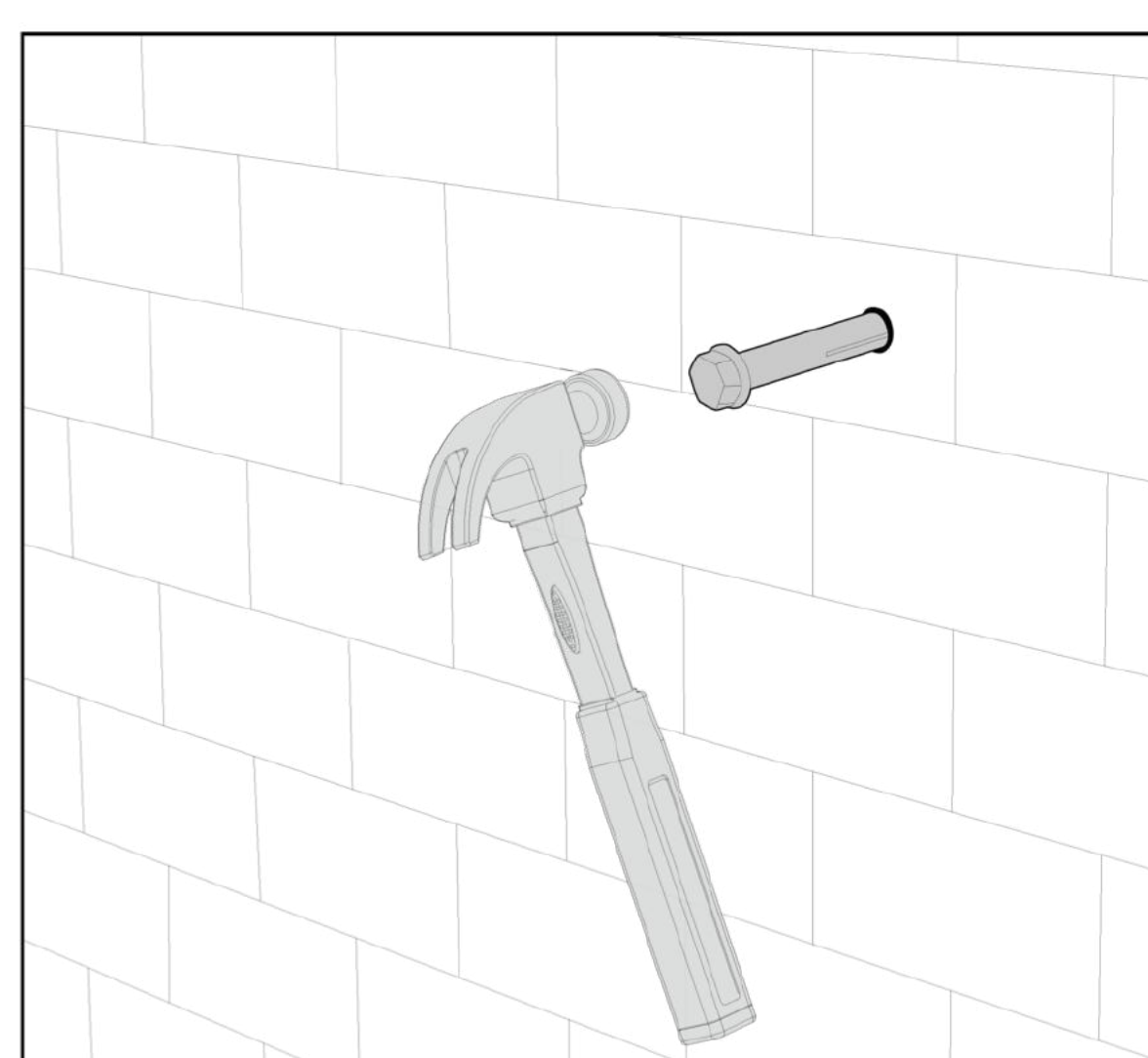
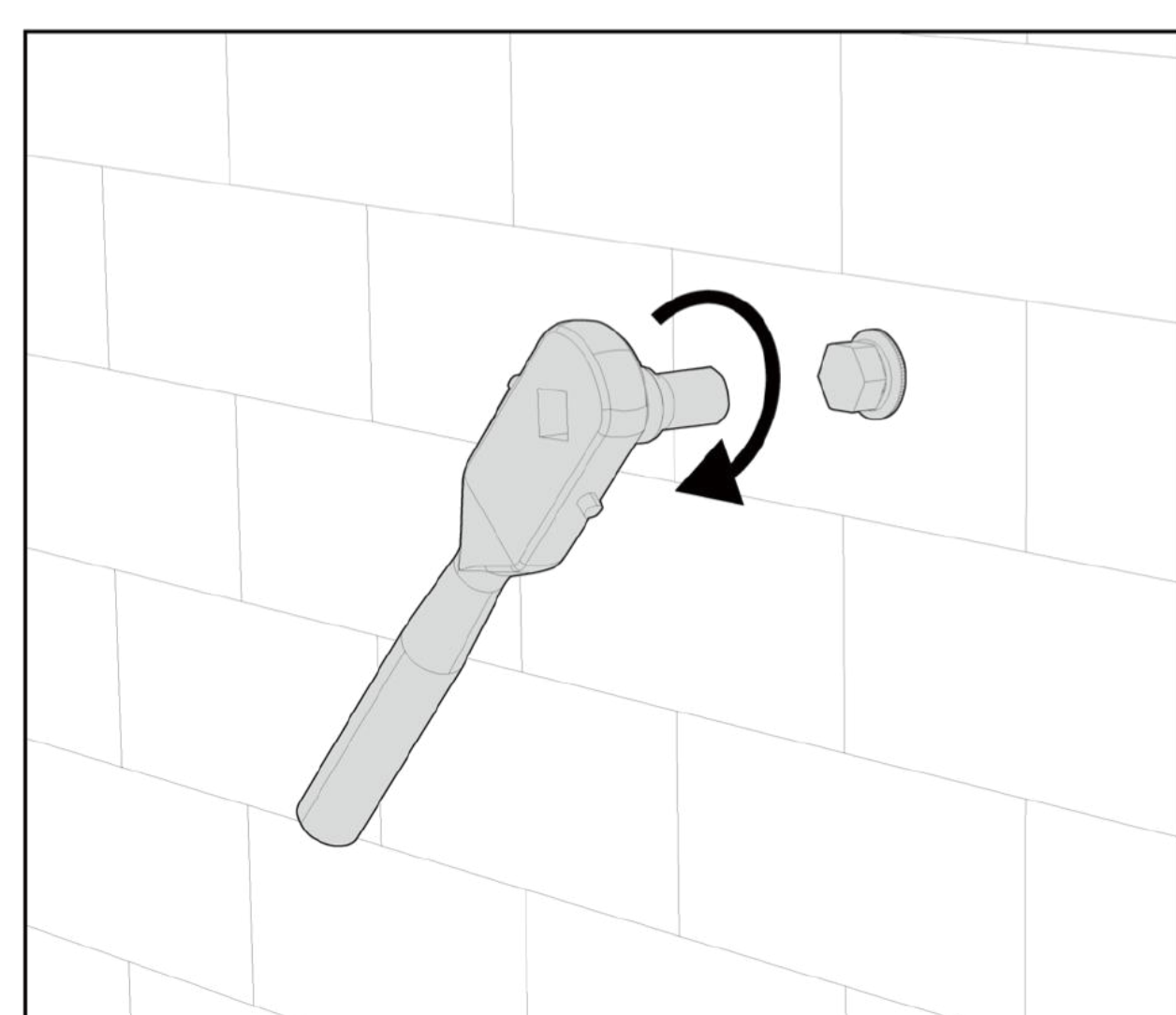
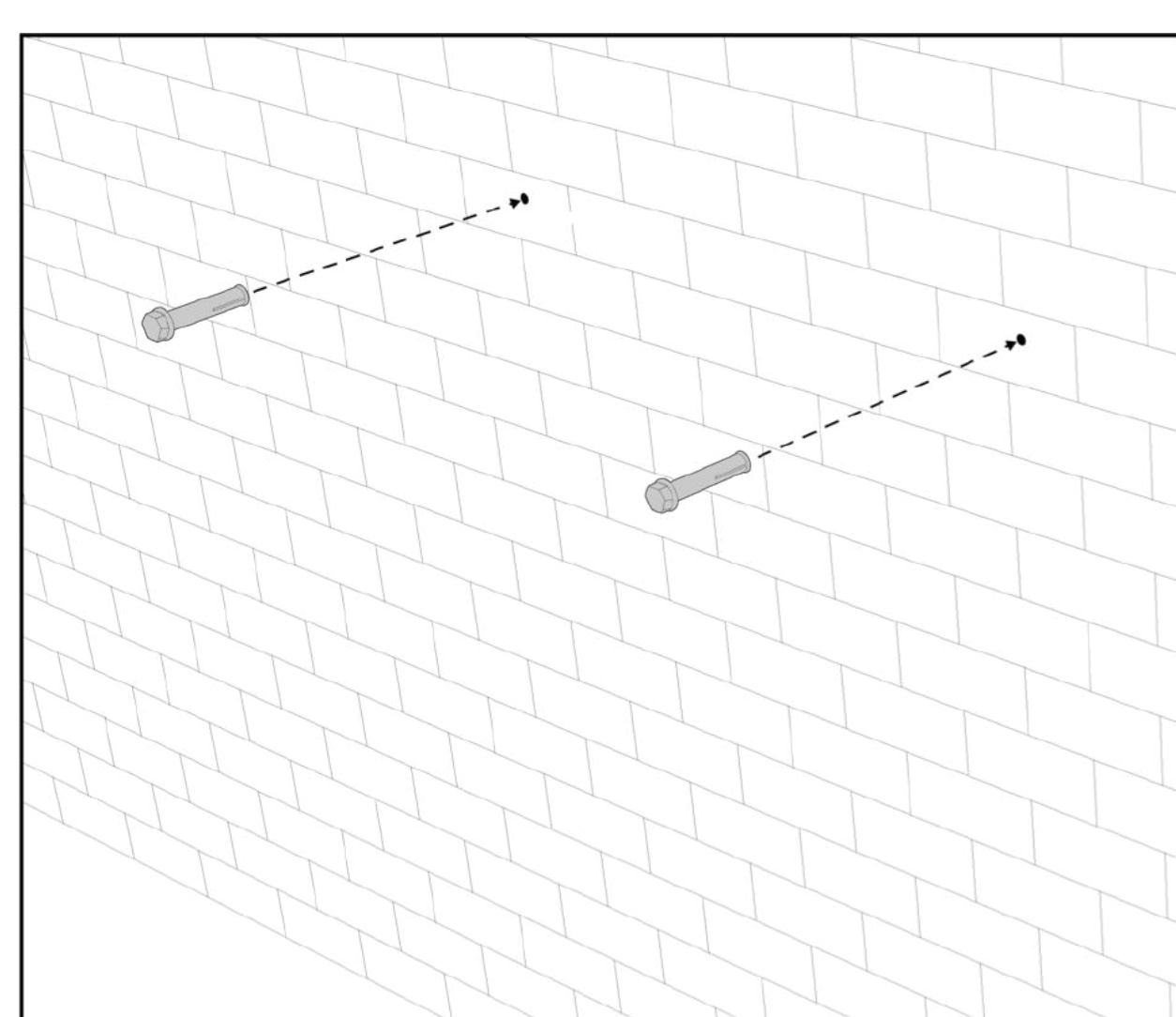

- d. Place the battery close to the wall, ensuring it is parallel to the wall and perpendicular to the floor.

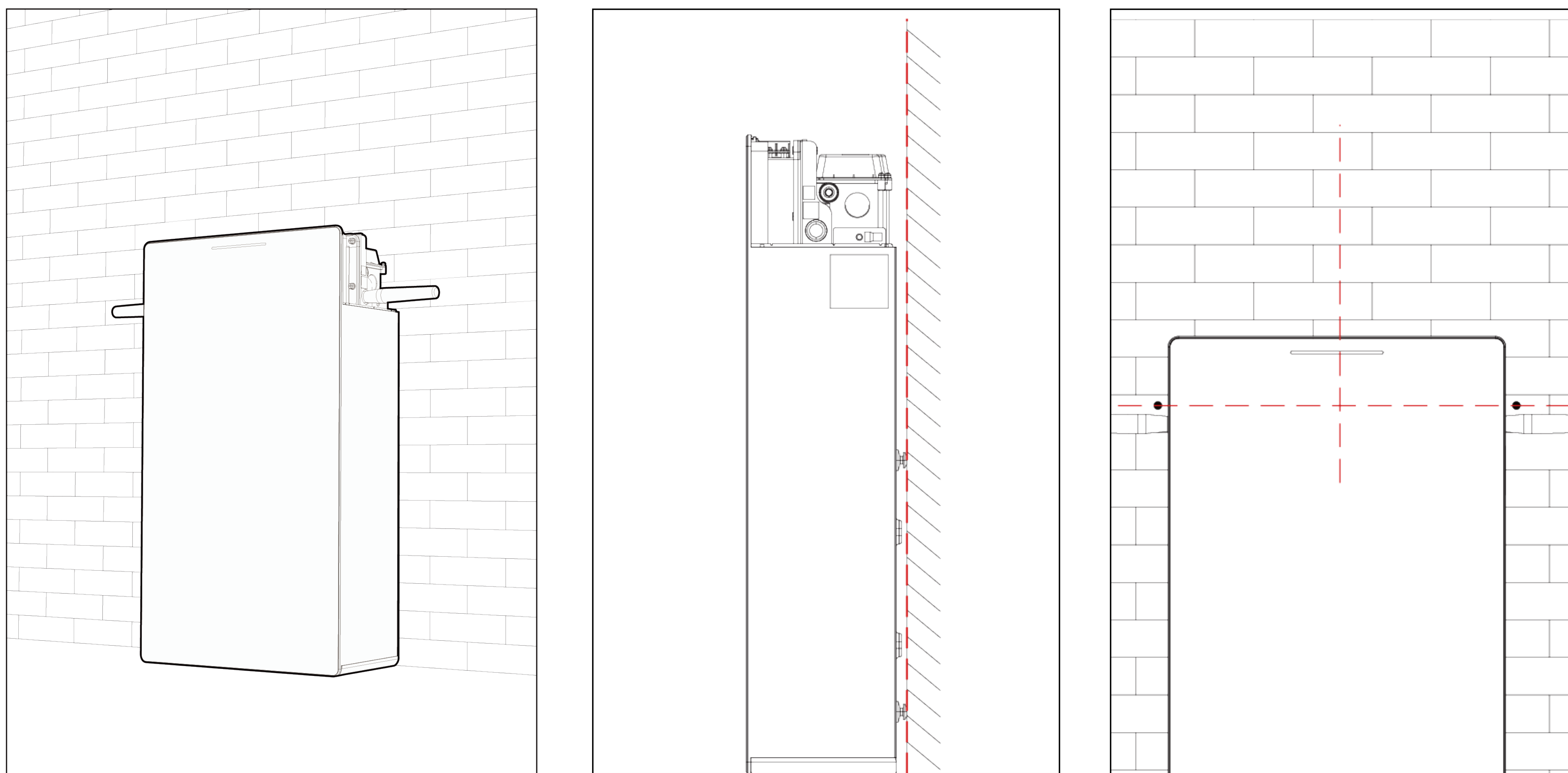

- e. Remove the handlebars and take out the mounting lugs and align them with the holes on the both sides. Insert the M6 screws and tighten the screws with a torque of 3 N·m.

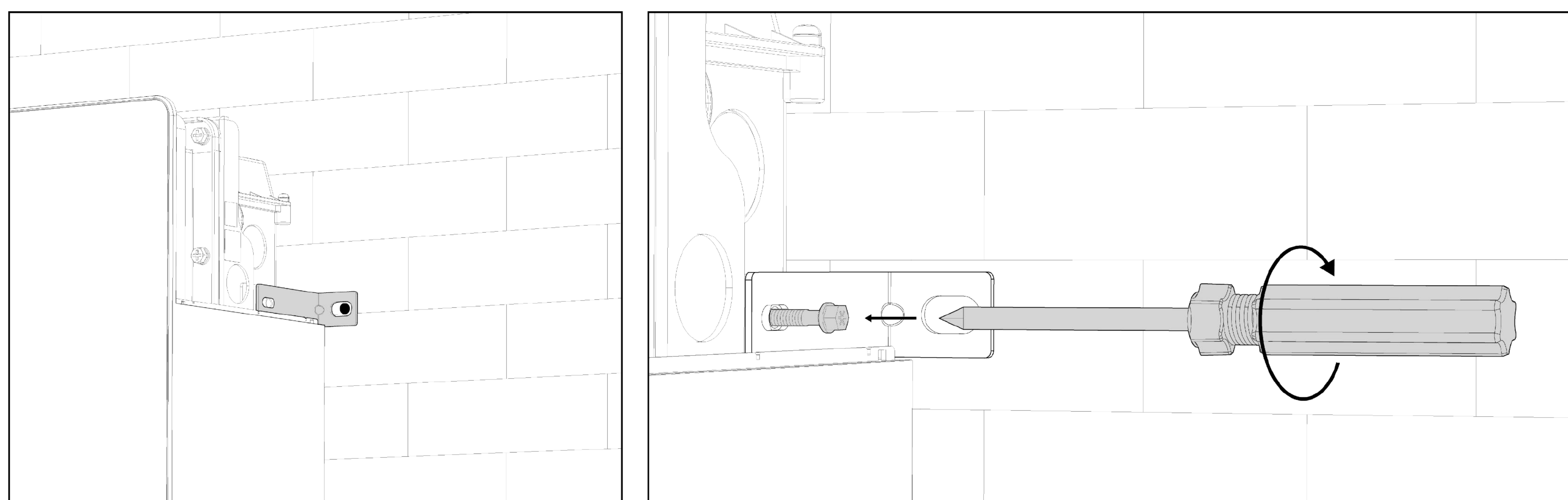

- f. Insert the M10 expansion screws and tighten the screws with a torque of 9–14 N·m.

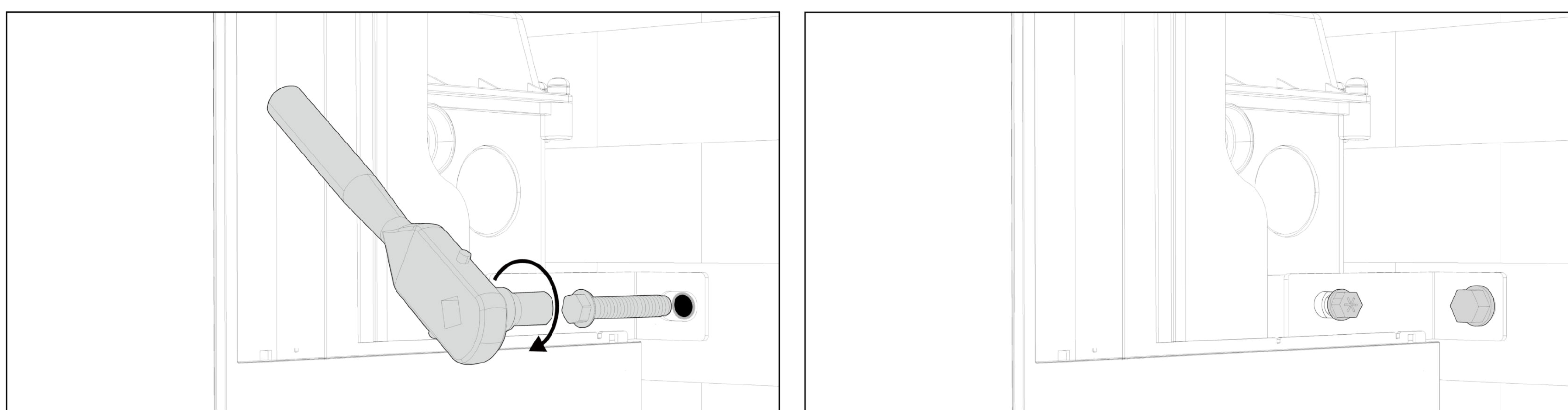

NOTE:

- Please do not tighten the screws completely until confirming that the mounting lugs can be fully installed.

4.3.2 Mount on the wall

- Take out the marking plate and place it on the wall. Use the spirit level to check that the plate is level, then make the marks.
- Drill at the four marks by using an electric drill with a bit ($\Phi 14$).

NOTE:

- The total weight for M-Battery, including the battery unit, and mounting plate, is 75 kg. The wall shall bear the battery weight.

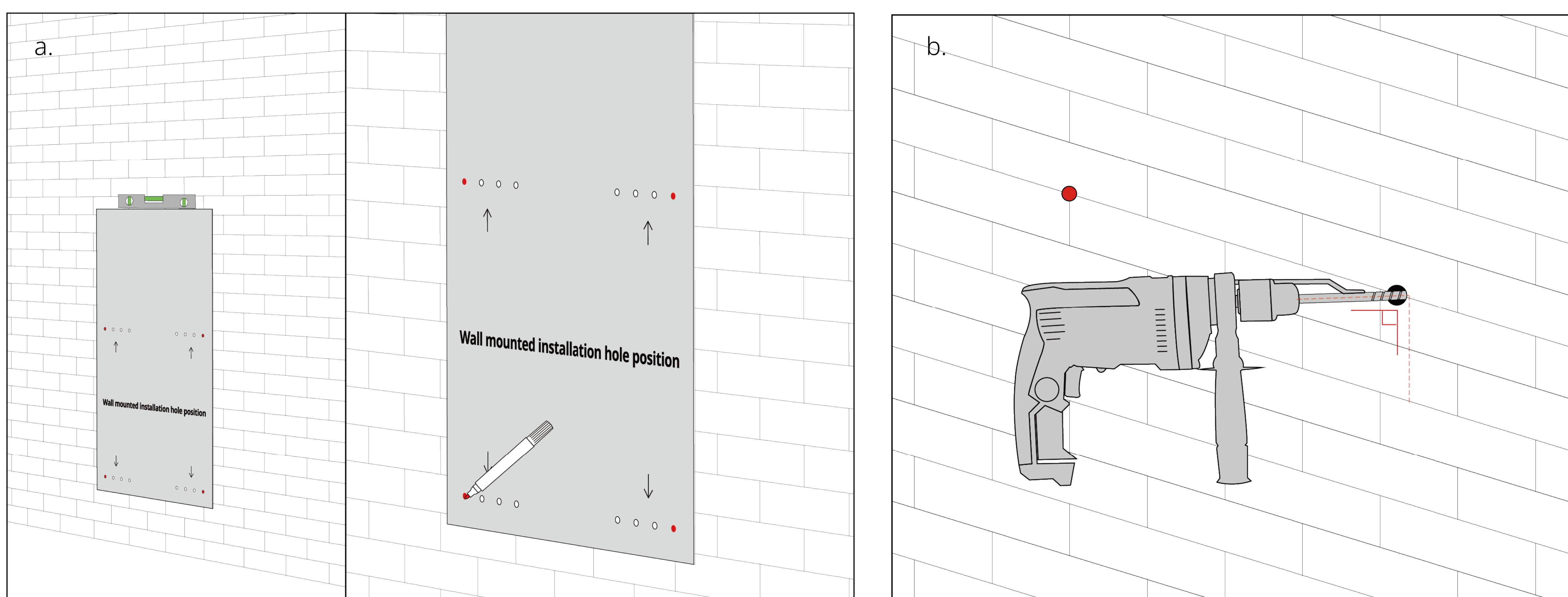

- Take out the expansion screws and align them with the holes. Knock them into the wall with a hammer and tighten the screws with a torque of 9–14 N·m, then loosen the screws.

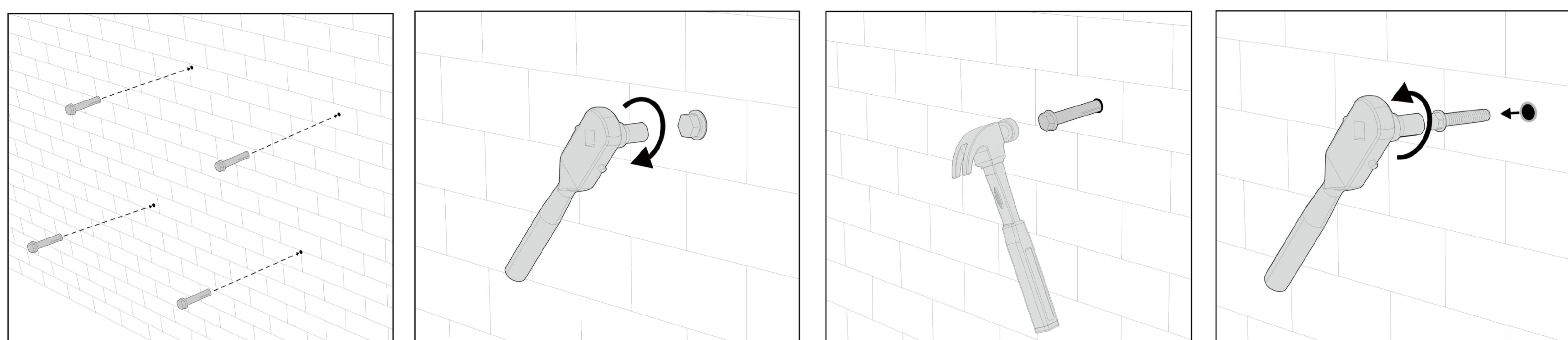

- d. Take out the mounting plate and align it with the holes. Insert and tighten the screws with a torque of 9–14 N·m.

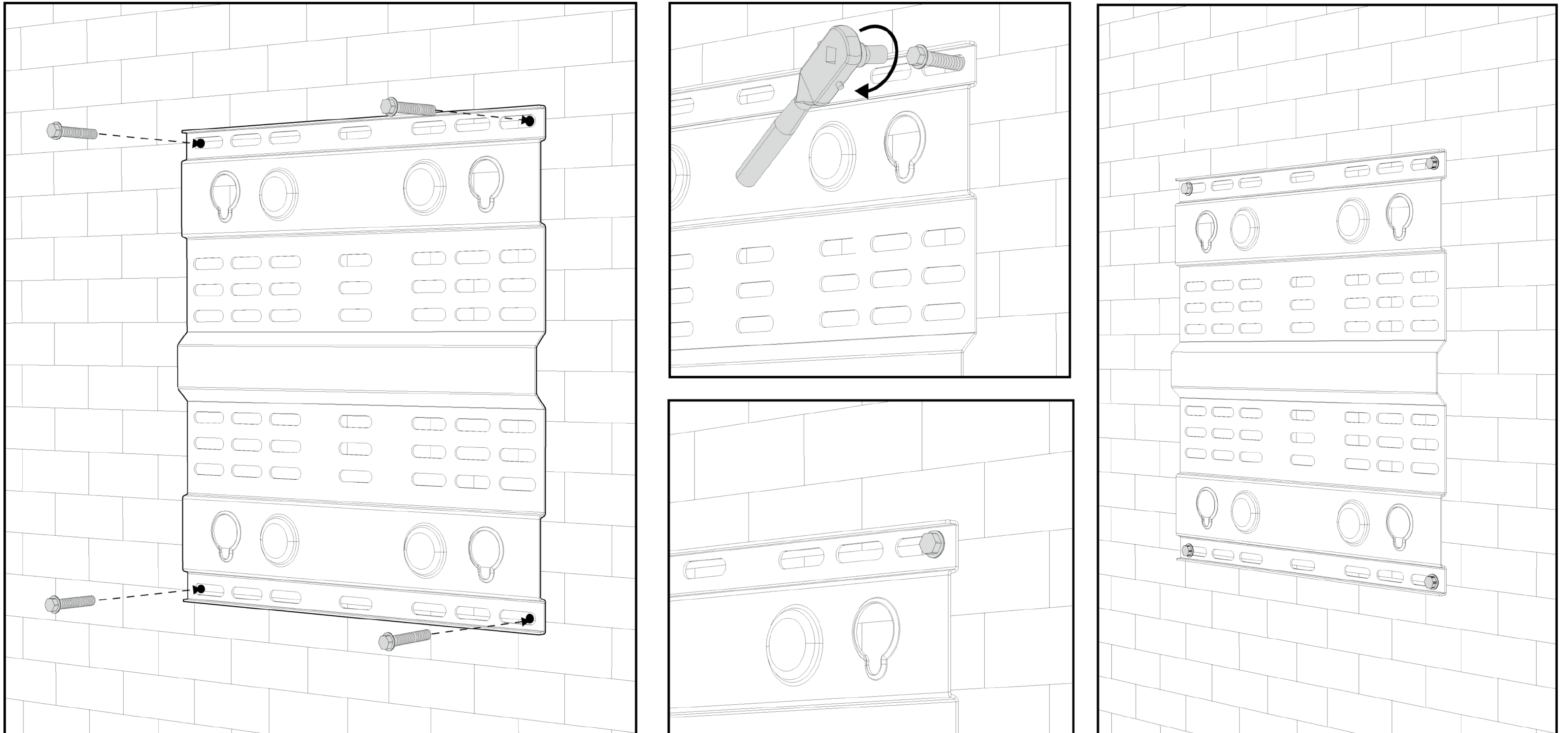

- e. Insert the four mounting columns on the back of the battery into the slide rail and slide them to the end, and then remove the handlebars.

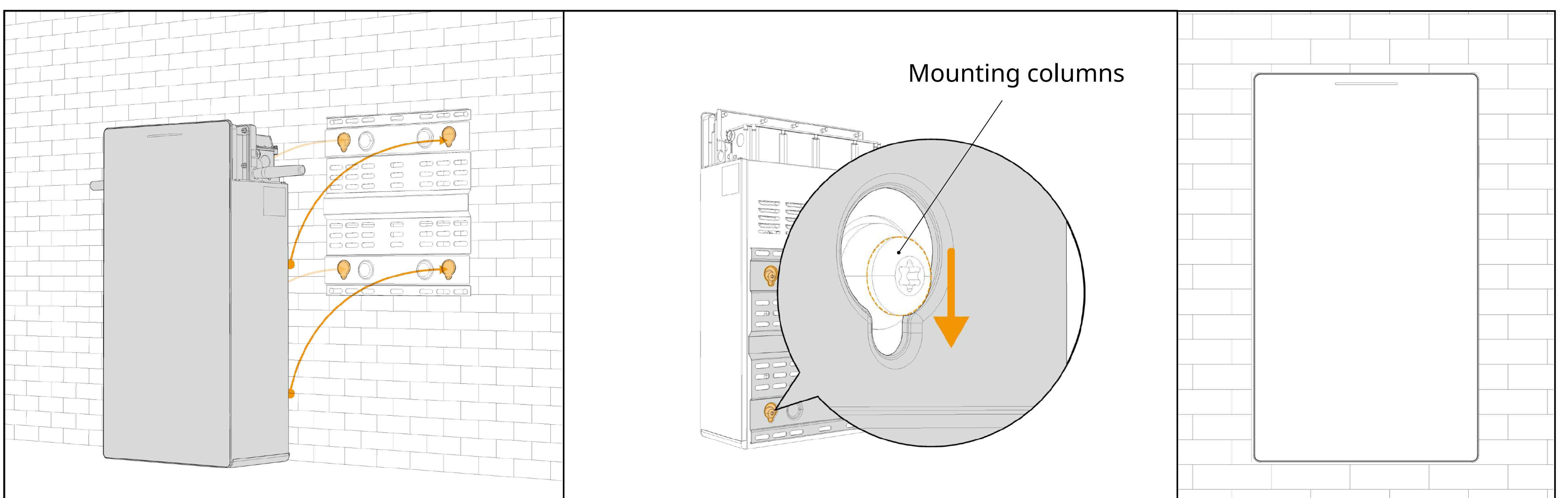

4.4 Remove the cover of the wiring cabinet

- a. Loosen the 13 screws and remove the cover of the wiring cabinet.

NOTE:

- Do not use the impact drivers and drills to tighten or loosen the screws.
- These screws are captive screws, do not attempt to unscrew them completely.

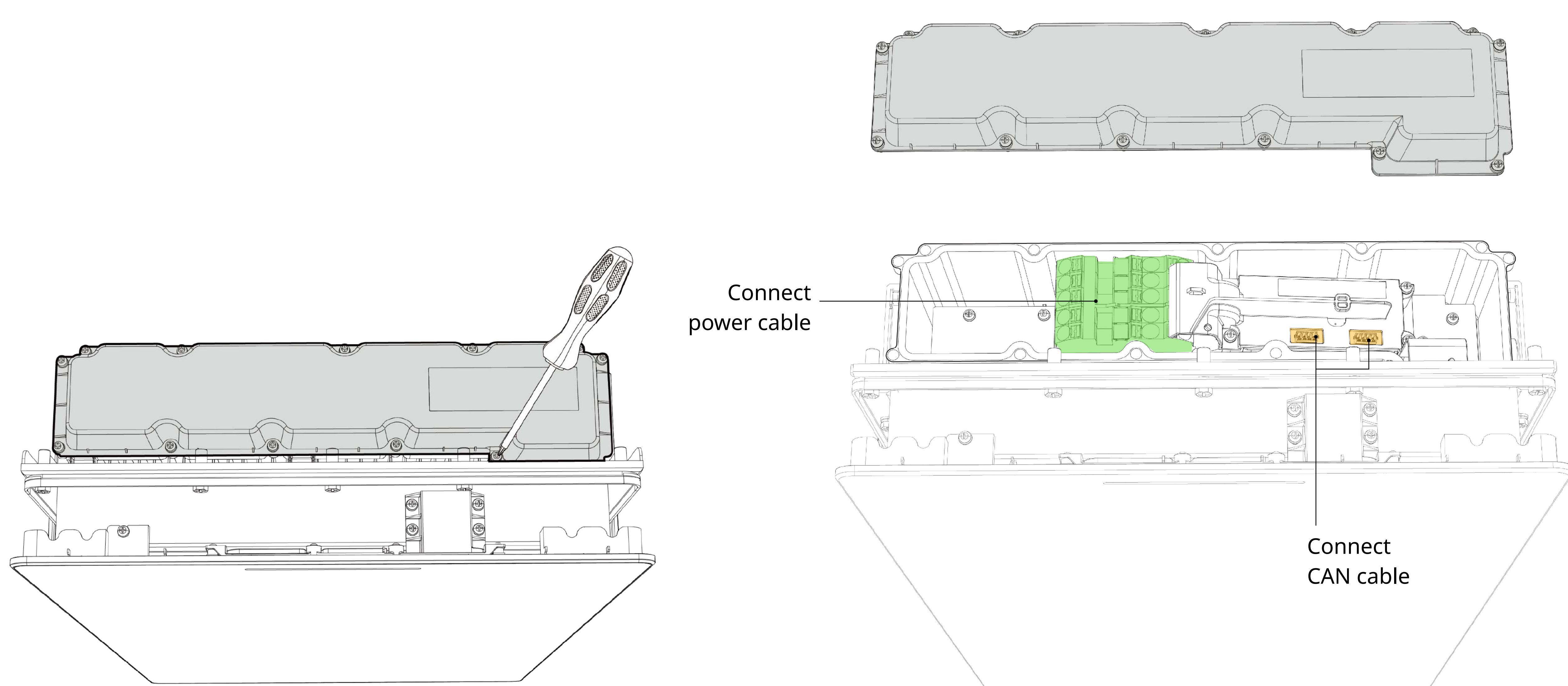

NOTE:

- The specifications of the AC terminal block are as follows:
Nominal voltage: 1000 Va.c.
Nominal current: 76 A
Operation temperature: from -40 °C to +105 °C
- The voltage between CAN-H, CAN-L, and CAN-GND is less than 3.3 Vdc.

- b. The details of the terminal are shown as below.

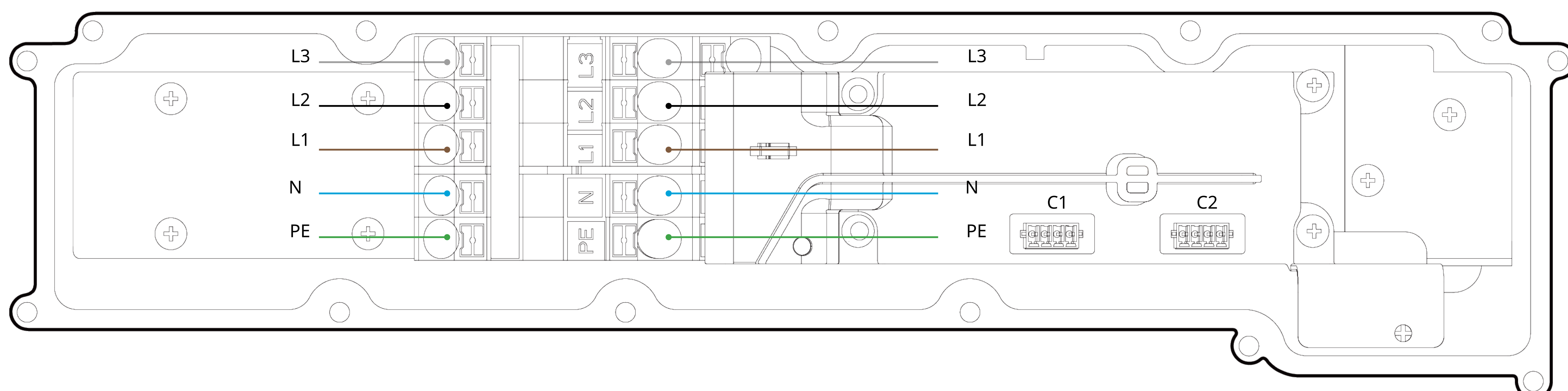

4.5 Remove the knockout

- Use the hammer and the screwdriver to remove the knockout. In the case of multiple batteries, remove the knockout on both sides.
- Mount the waterproof fittings on the holes.
- Tighten the lock nuts of the glands with a torque of 4–5 N·m and the sealing nuts with a torque of 7–7.5 N·m.

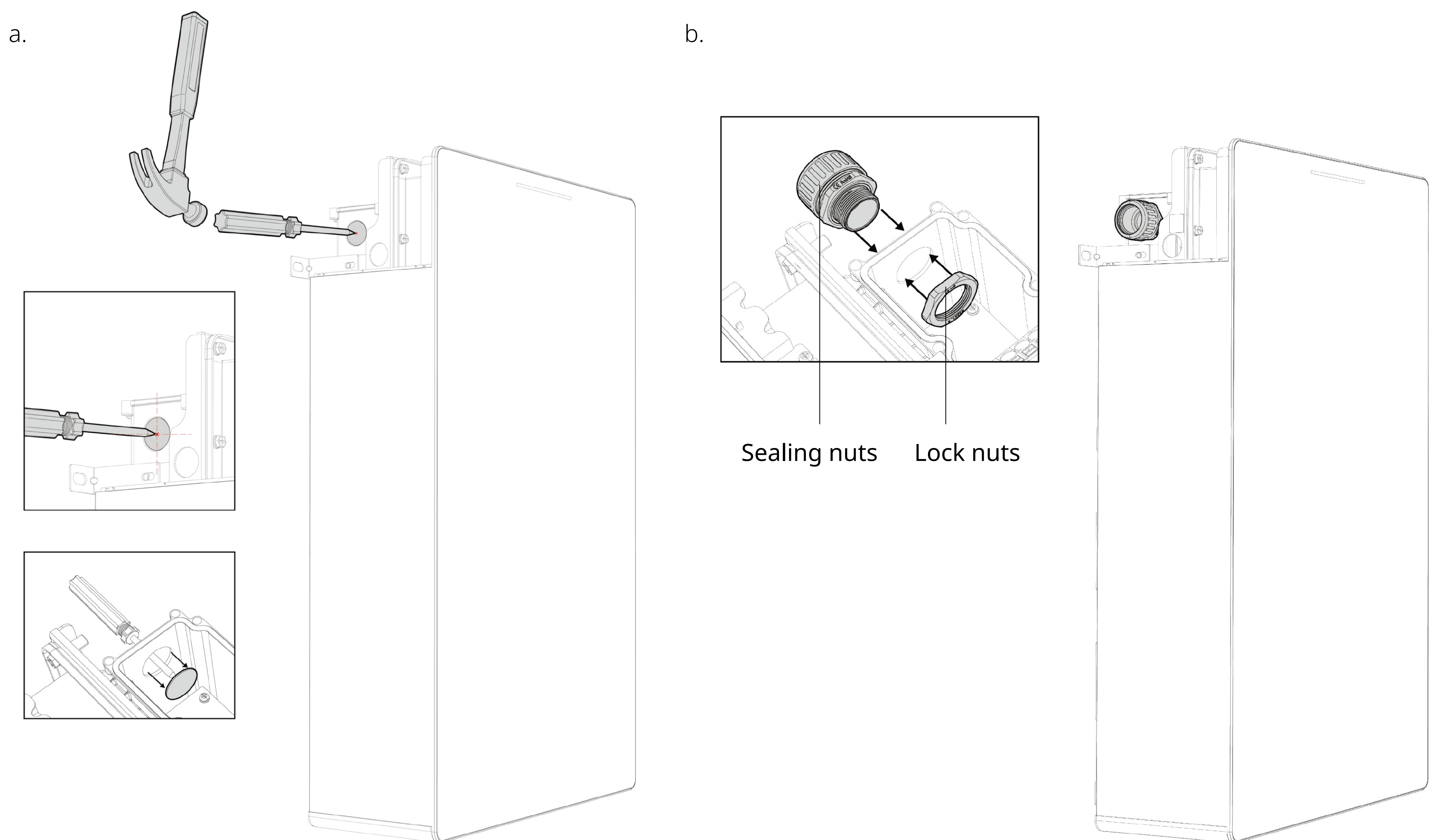

NOTE:

- The screwdriver should be aligned with the center of the knockout.

4.6 Wire the cables

NOTE:

- The N wire of the MS-7K-U-1P/MS-7K-U-3P must be permanently connected to the N wire of the power grid.

NOTE:

- The cables must connect to the battery breaker and terminals in the combiner. The wiring is different for each model of the combiner. Please check the label inside the combiner for more information.
- Improperly connected L and N will damage the equipment.
- The external devices connected to the M-ELV Battery should be used in accordance with the requirements of AS/NZS 4777.1.

4.6.1 Single battery scenario

Section A. Wire the CAN cable

- Connect the 3m CAN communication cable to the communication terminal as the label in the combiner.
- Bring in the CAN cables from the combiner through the hole of the battery.
- Remove the resistor on the C1 terminal, and connect the CAN communication cable to the proper terminal as the label.
- Please do not perform any operations on the C2 terminal and resistor.
- Arrange the cables and check the wiring is correct.

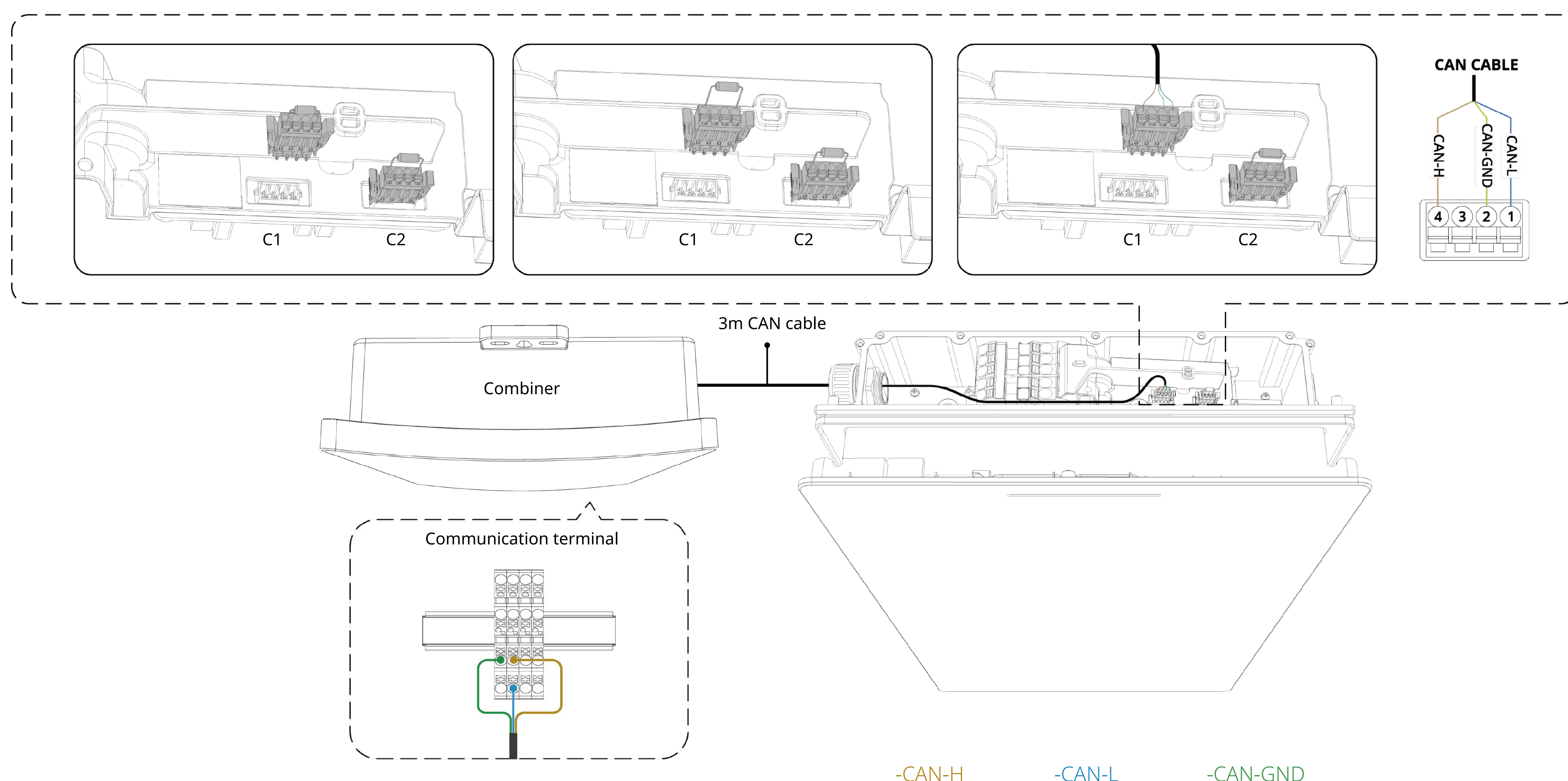

Section B. Wire the power cable

NOTE:

- The cables must connect to the battery breaker and PE terminal in the combiner. Please check the label inside the combiner for more information. Incorrect connection of L and N will damage the equipment.
- When stripping the cable, remove approximately 120 mm of the insulation layer from the power cable.
- The length of the PE wire should be approximately 2 cm longer than the other wires.

- Connect the cables to the battery breaker and PE terminal block in the combiner.
- Bring in the power cables from the combiner through the hole of the battery.
- Connect the cables to the power and PE terminal block in the battery.

NOTE:

- The recommended rated residual current for compatible RCDs is greater than 100mA, with 30mA being the minimum acceptable threshold. A residual current device RCD type A can be used. Additionally, the maximum current-carrying capacity of the RCD should match the parameters of the grid-side breaker within the CombinerPro.

Single-phase application (MS-7K-U-1P)

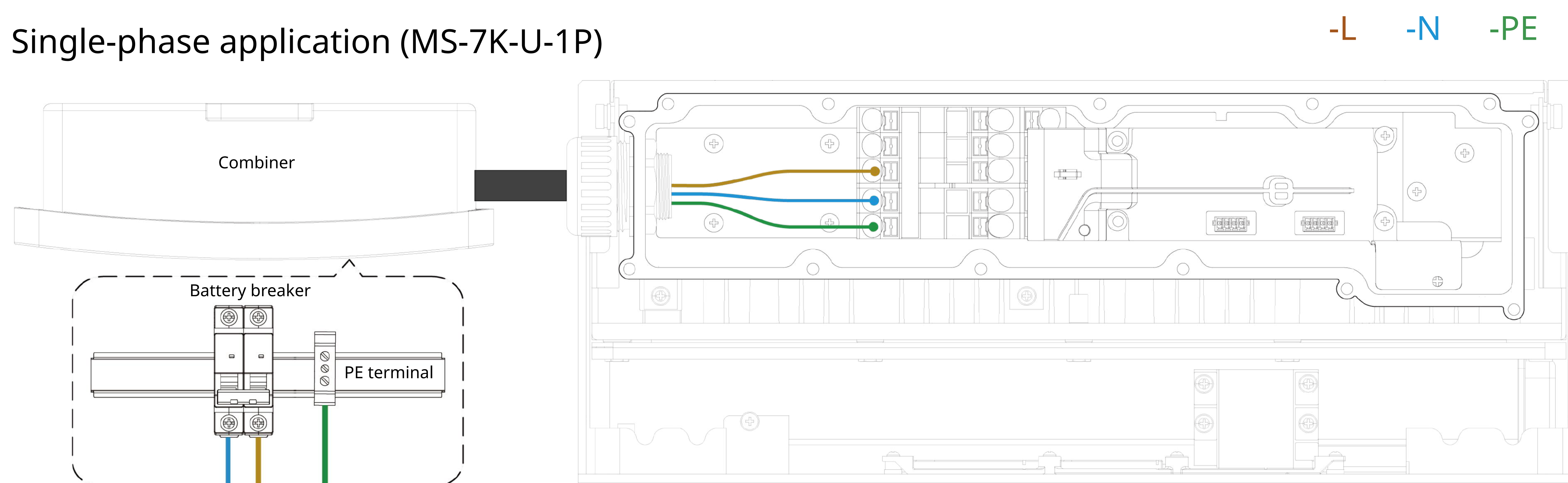

NOTE:

- For single-phase systems, the plug-in bridge must be fully inserted as shown.
- After the installation, confirm that the plug-in bridge is not loose.

NOTE:

- Miniature Circuit Breaker (MCB) is used for protection. The MCB specification must meet the following requirements: IEC 60947-2, trip curve C: - characteristic of short-circuit protective device each pole, rated 63A, for single-phase system and three-phase system at least 10 kA fault current interrupting capacity at 230V/pole.

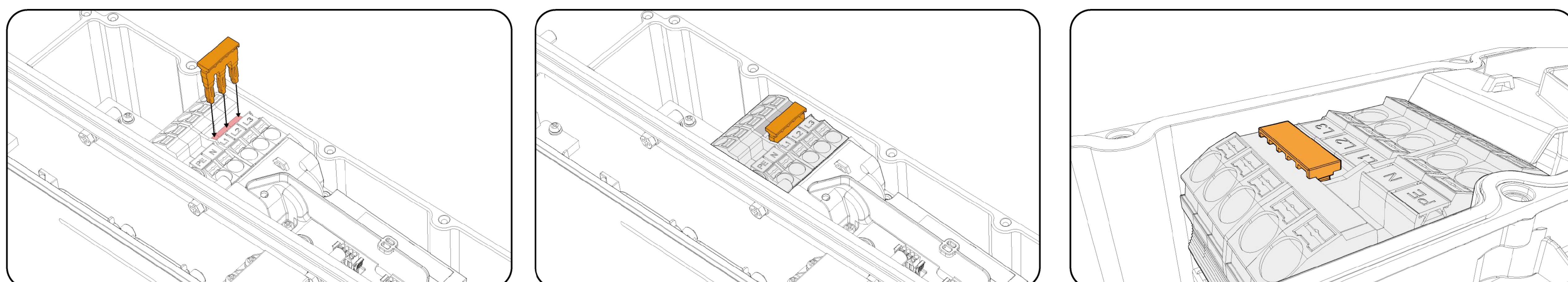

Three-phase application (MS-7K-U-3P)

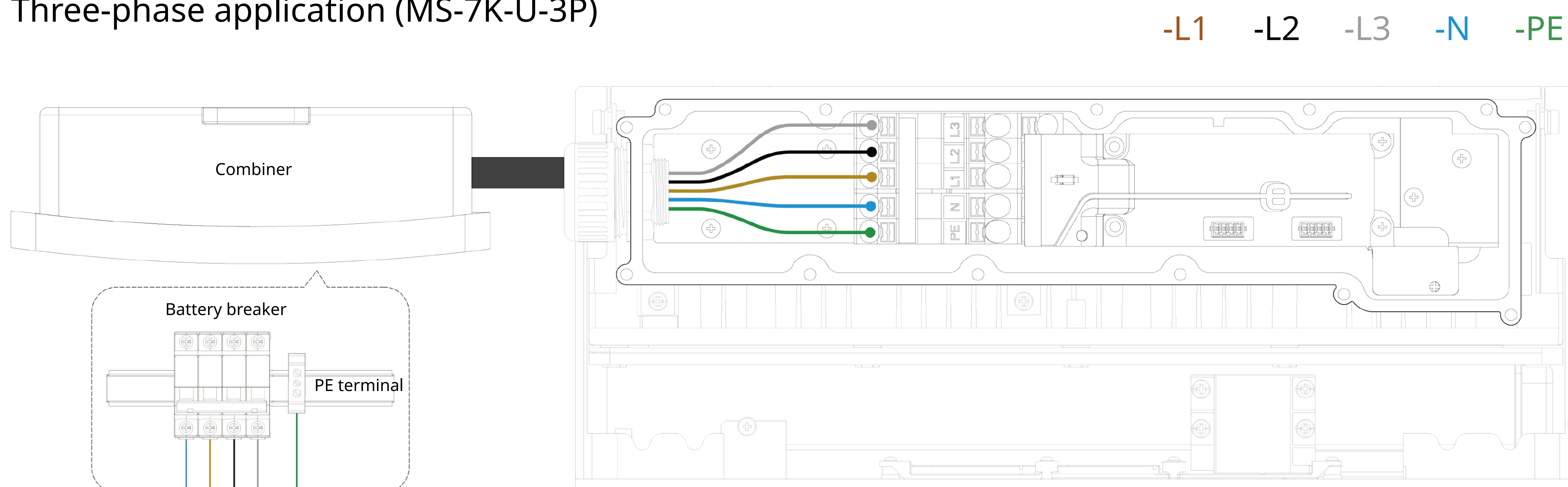

4.6.2 Multiple batteries scenario

Section A. Wire the CAN cable

- Connect the 3m CAN communication cable to the communication terminal as the label in the combiner.
- Bring in the 3m and 1.5 m CAN communication cable through the hole of the battery.
- For the battery 1, remove the resistor on the C1 and C2 terminal, and then connect the cable to the C1 and C2 terminal as below.

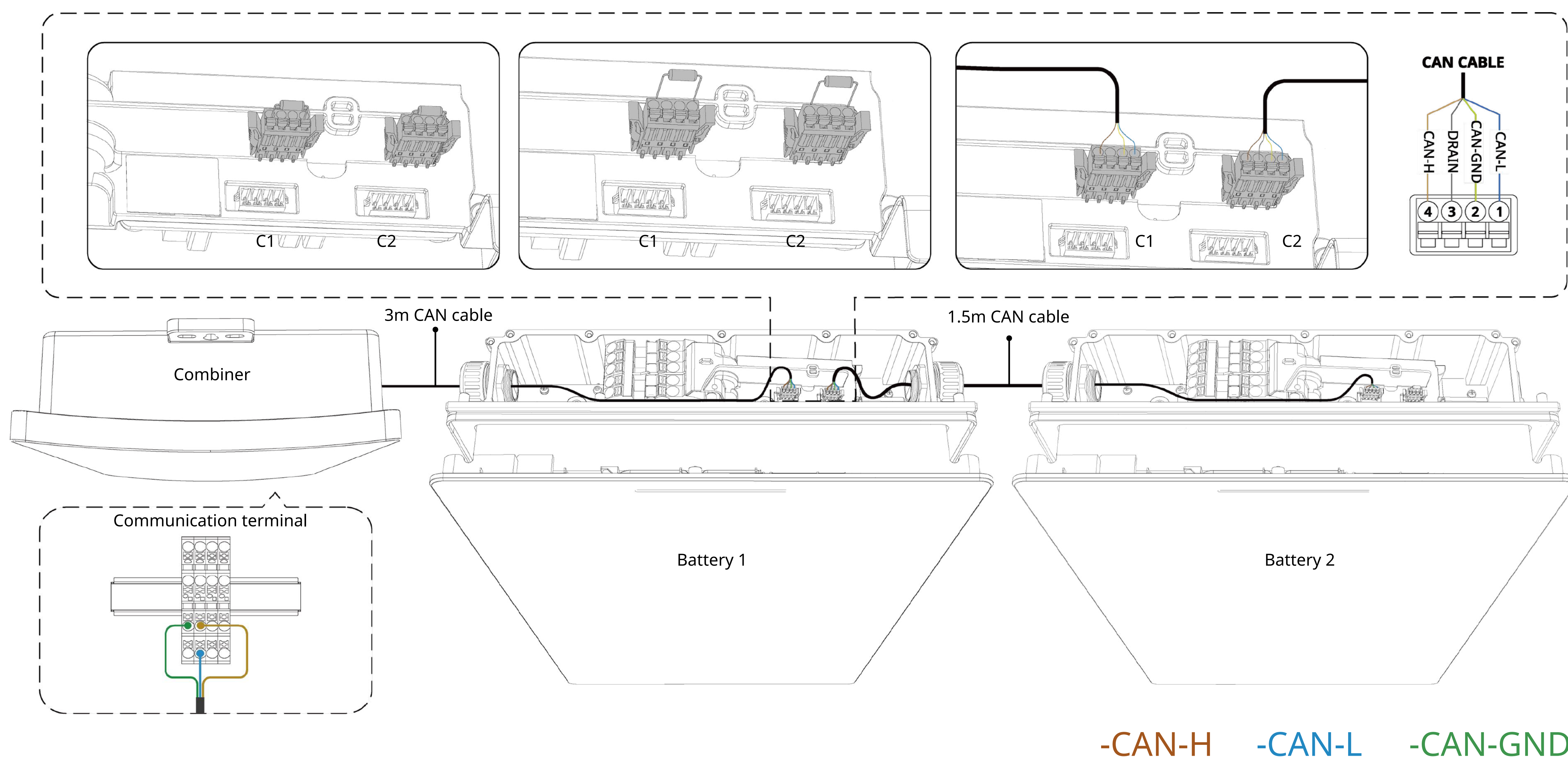

d. For the battery 2, remove the resistor on the C1 terminal, and then connect the cable to the C1 terminal as below. Please do not perform any operations on the C2 terminal and resistor.

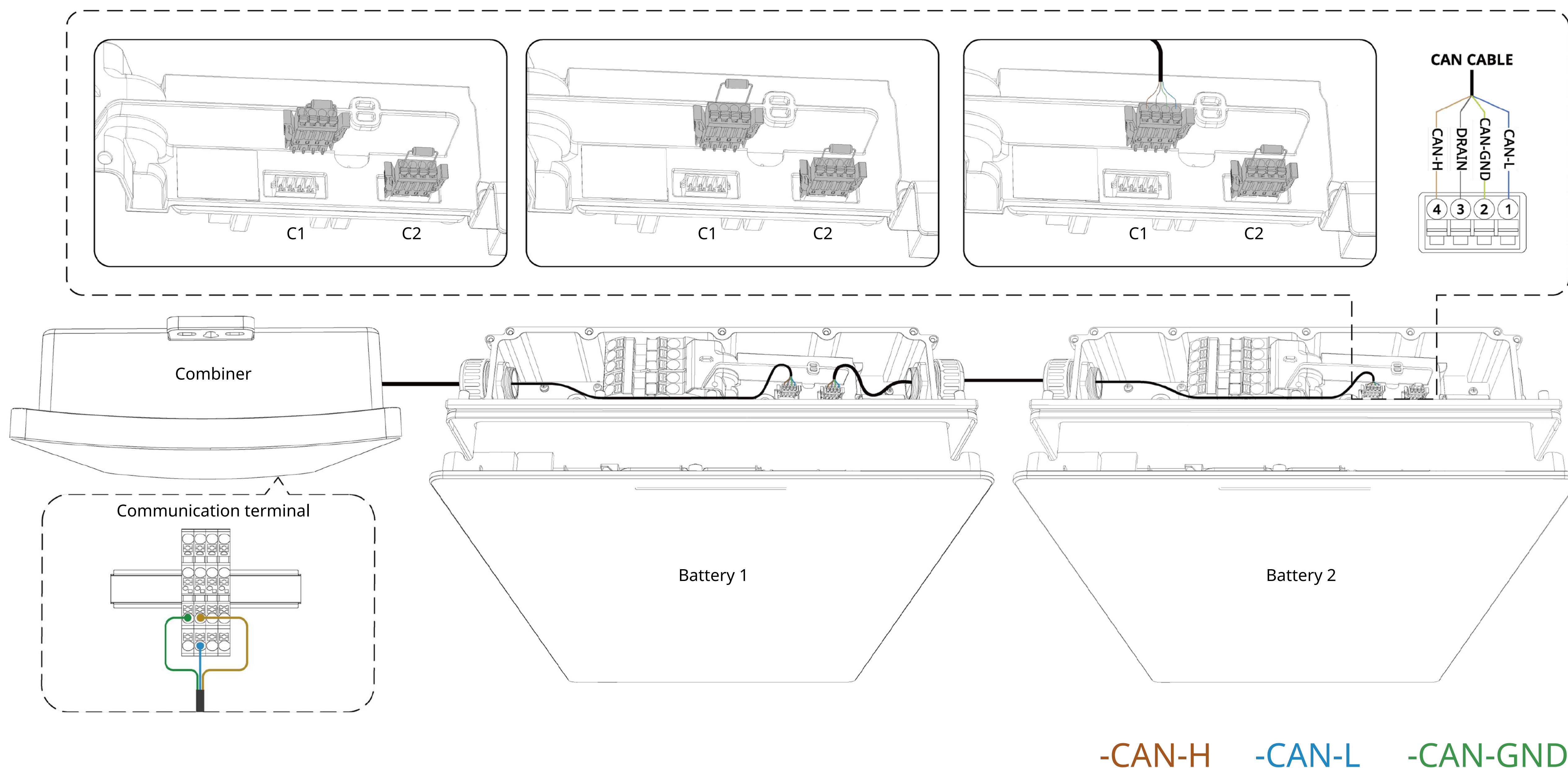

-CAN-H -CAN-L -CAN-GND

e. Arrange the cables and check the wiring is correct.

NOTE:

- When the M-Battery is in the multiple batteries scenario, the number of batteries connected to the M-Combiner is subject to the following constraints: 1 battery for MC100L, 3 batteries for MC100, 6 batteries for MC100-T.

MS-7K-U-1P

Number of units	Maximum current	Recommended wire size	Notes
1	23.8	4 mm ²	/
2	47.6	10 mm ²	/
3	50	10 mm ²	Software limit for maximum current
4	50	10 mm ²	Software limit for maximum current
5	50	10 mm ²	Software limit for maximum current
6	50	10 mm ²	Software limit for maximum current

MS-7K-U-3P

Number of units	Maximum current	Recommended wire size	Notes
1	7.9	2.5 mm ²	/
2	15.9	2.5 mm ²	/
3	23.9	4 mm ²	/
4	31.9	6 mm ²	/
5	39.9	10 mm ²	/
6	47.9	10 mm ²	/

Section B. Wire the power cable

NOTE:

- The cables must connect to the battery breaker and PE terminal in the combiner. Please check the label inside the combiner for more information. Incorrect connection of L and N will damage the equipment.
- When stripping the cables, remove approximately 120 mm of the cable's insulation layer on the left side of the battery and 270 mm of the cable's insulation layer on the right side.

- Connect the cables to the battery breaker and PE terminal in the combiner.
- Bring in the power cables from the combiner through the hole of the battery.
- Connect the cables to the power and PE terminal block in the battery.

NOTE:

- The recommended rated residual current for compatible RCDs is greater than 100mA, with 30mA being the minimum acceptable threshold. A residual current device RCD type A can be used. Additionally, the maximum current-carrying capacity of the RCD should match the parameters of the grid-side breaker within the CombinerPro.

Single-phase application (MS-7K-U-1P)

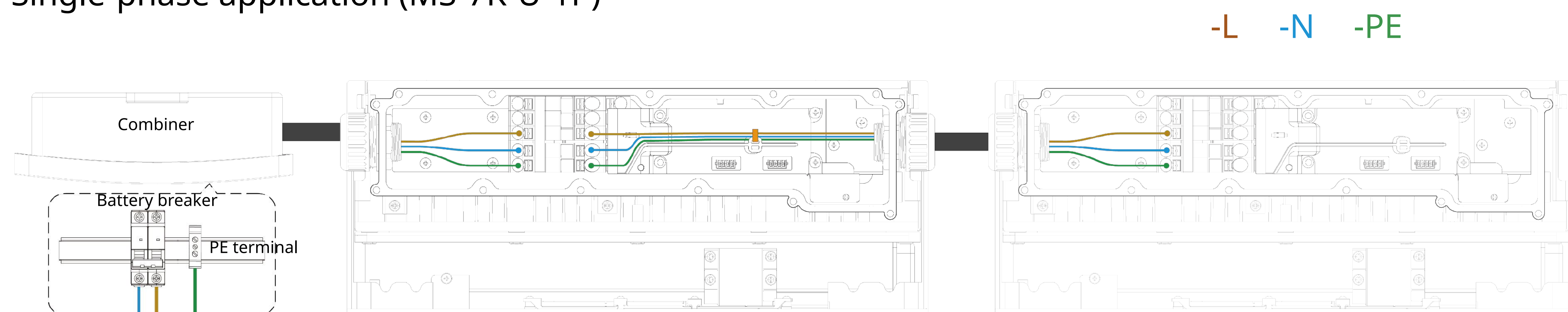

NOTE:

- For single-phase systems, the plug-in bridge must be fully inserted as shown.
- After the installation, confirm that the plug-in bridge is not loose.
- If batteries are used in parallel (more than two units), please use a 10mm² cable for the ground wire; or connect the ground wire to the unused AC terminal on the last energy storage unit as well.

NOTE:

- Miniature Circuit Breaker (MCB) is used for protection. The MCB specification must meet the following requirements: IEC 60947-2, trip curve C: - characteristic of short-circuit protective device each pole, rated 63A, for single-phase system and three-phase system at least 10 kA fault current interrupting capacity at 230V/pole.

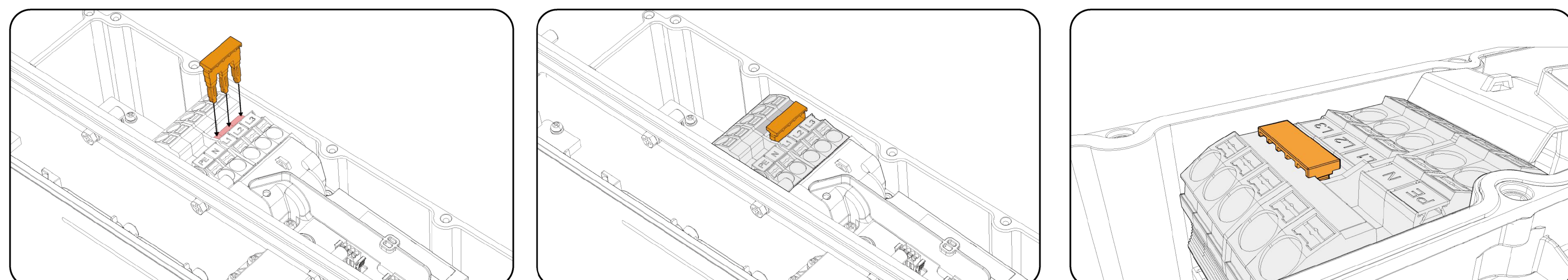

Three-phase application(MS-7K-U-3P)

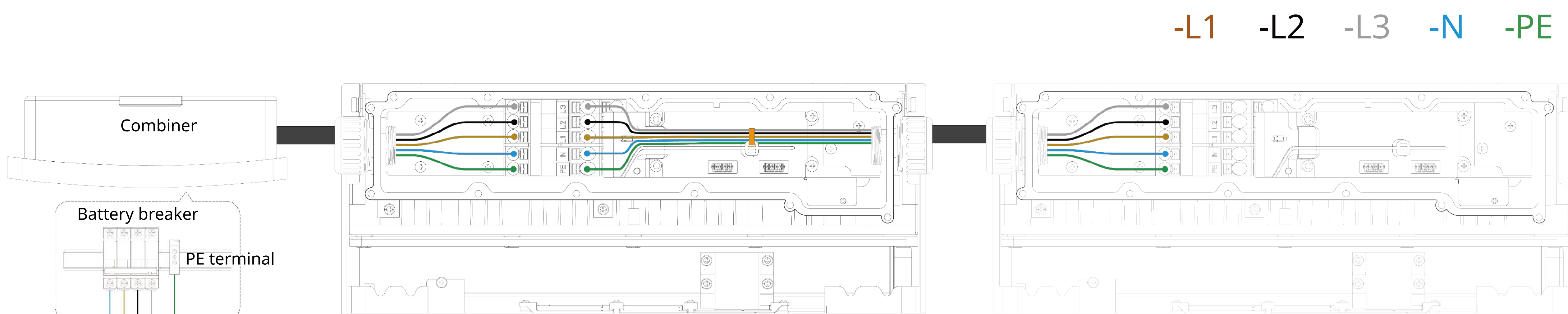

4.7 Close the cover of the wiring cabinet

- a. Re-install the cover. Follow the sequence (from 1 to 13) as shown in the figure to tighten the 13 screws.

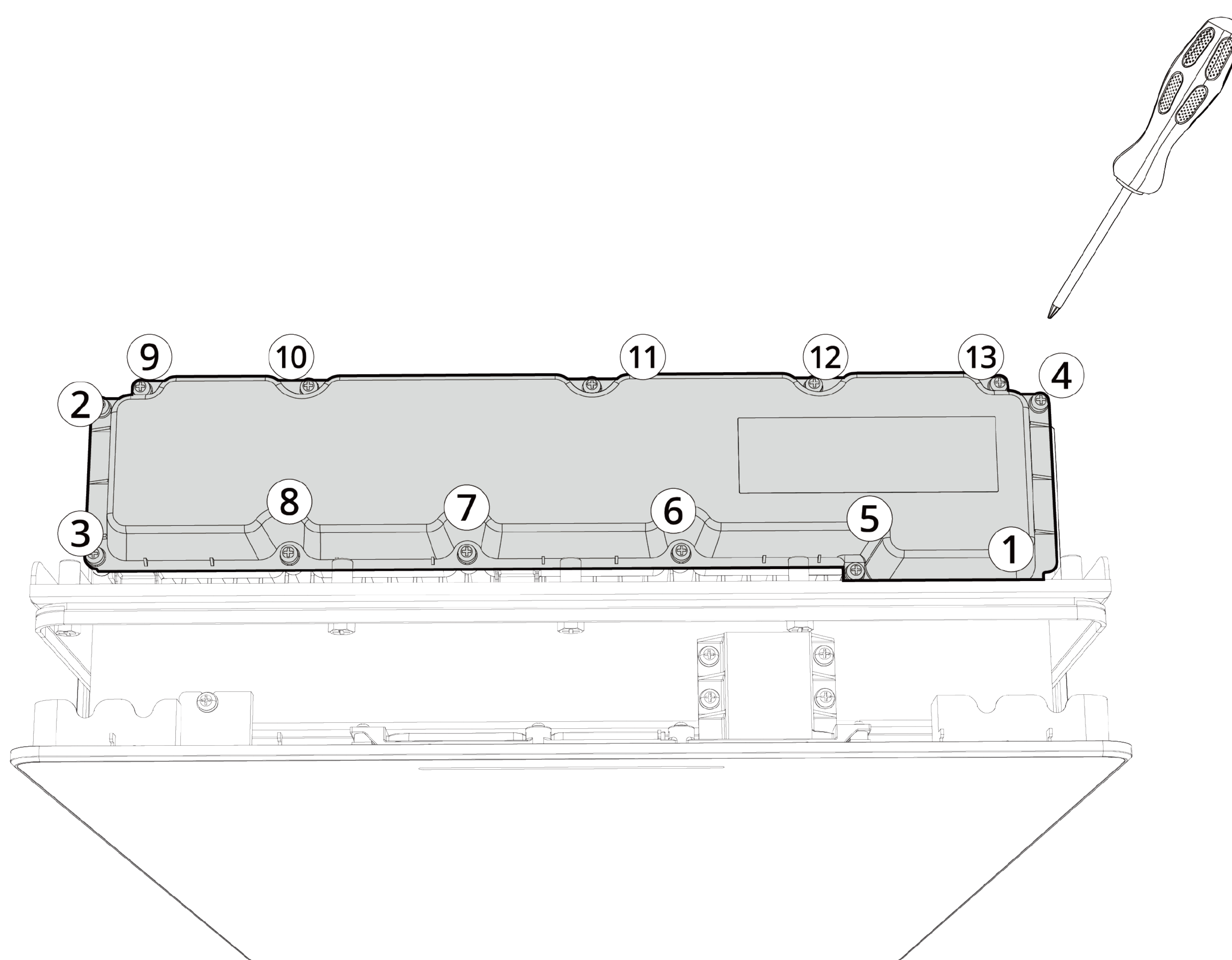

NOTE:

- Do not use the impact drivers and drills to tighten or loosen the screws.

4.8 Remove the knockout of the upper cover

- a. Wear the protective gloves and remove the knockout of the upper cover.

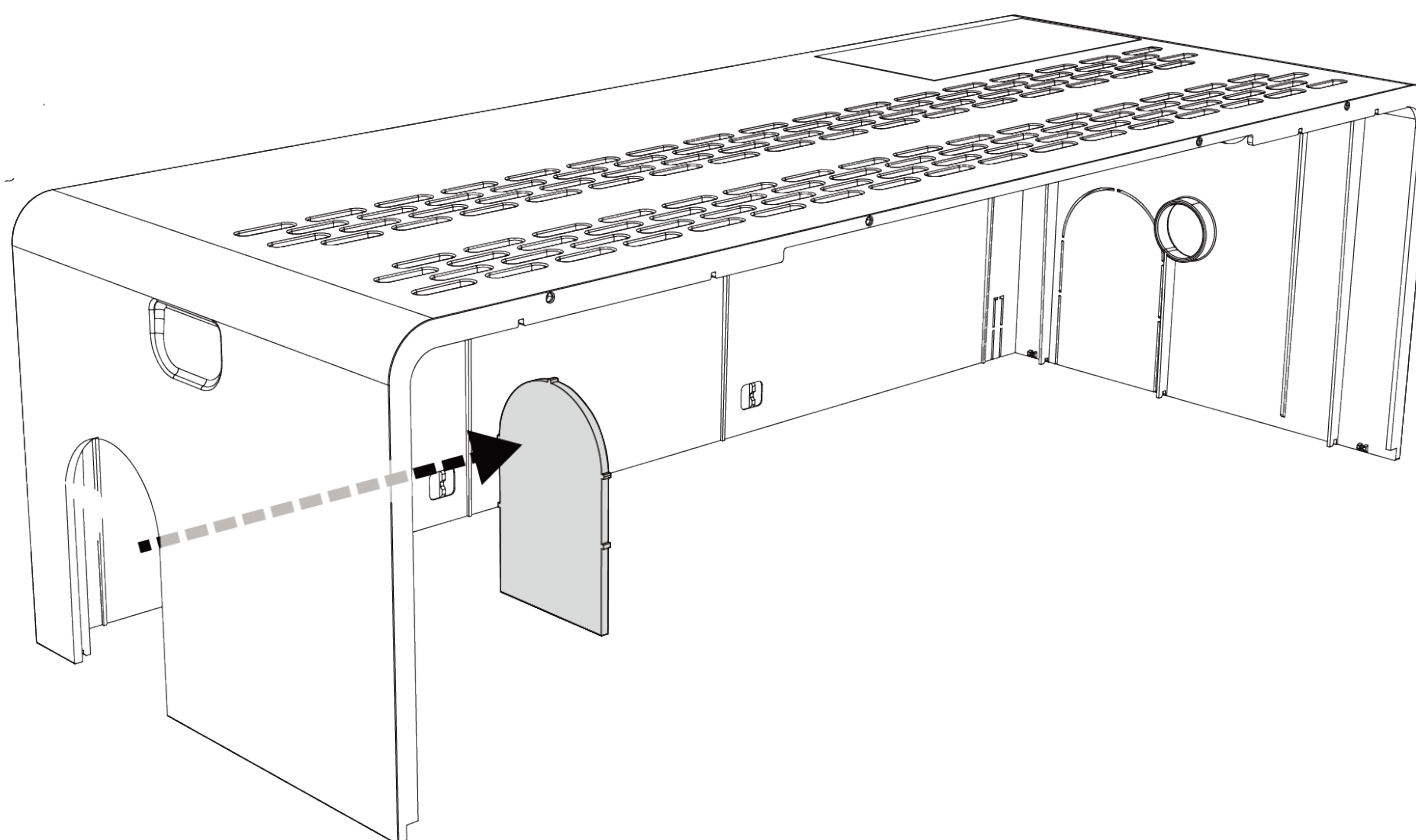
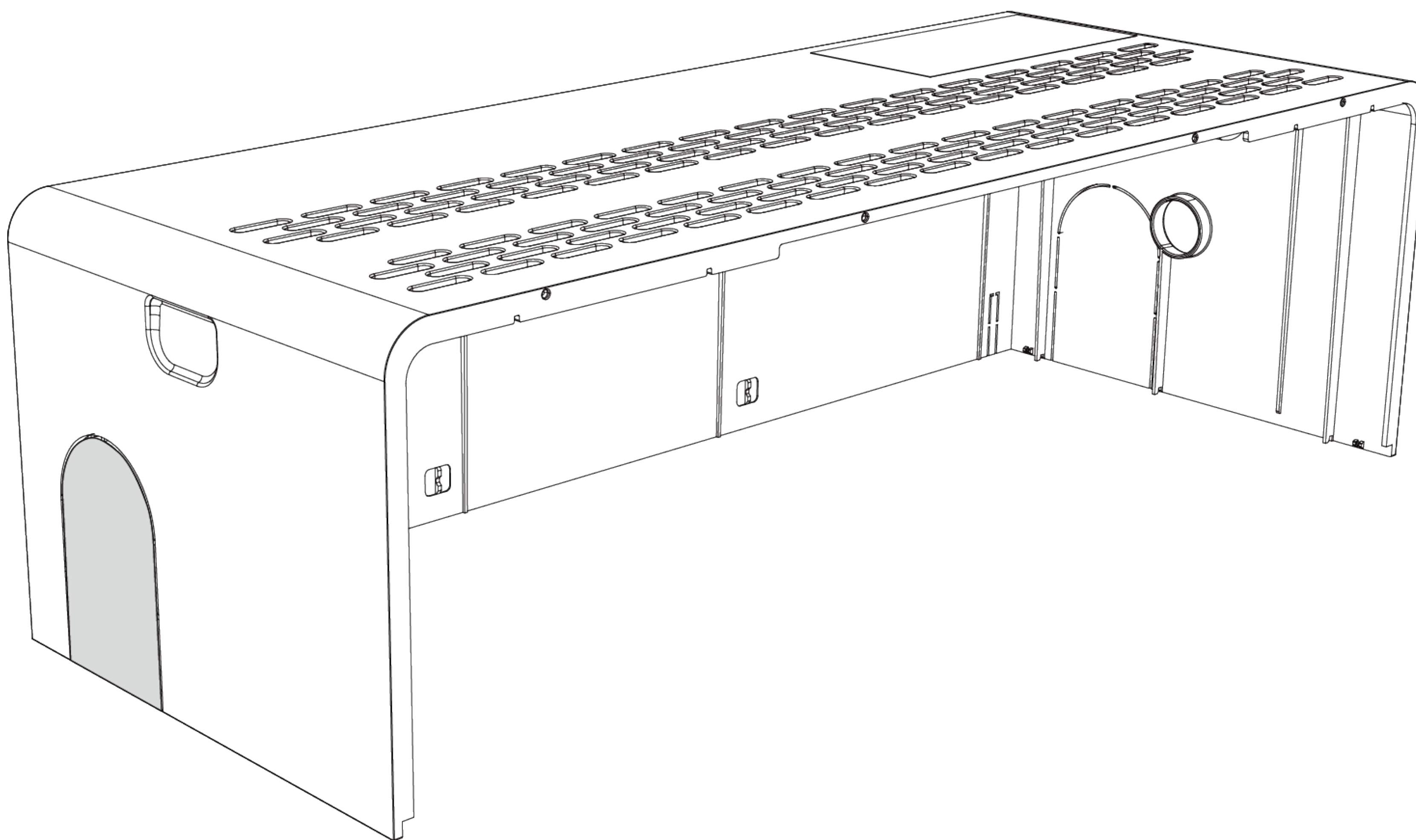
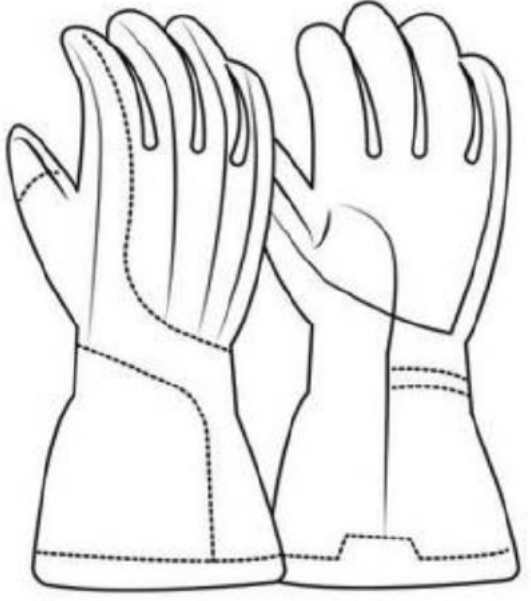

NOTE:

- Please remove the knockout according to the wiring conditions.

4.9 Close the upper cover

- a. Close the upper cover.

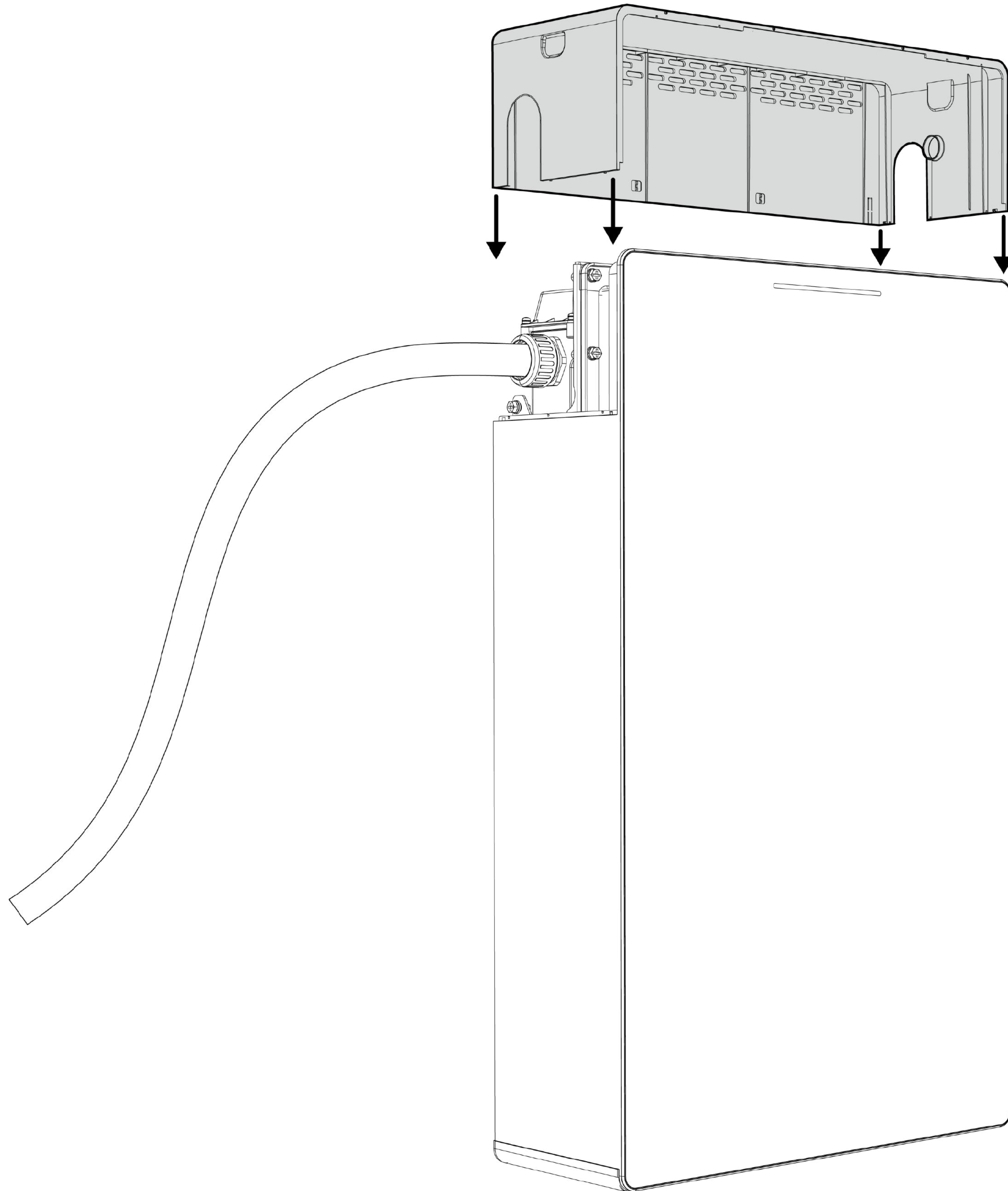

NOTE:

- For floor mounting, remove the mounting buckles of the upper cover.

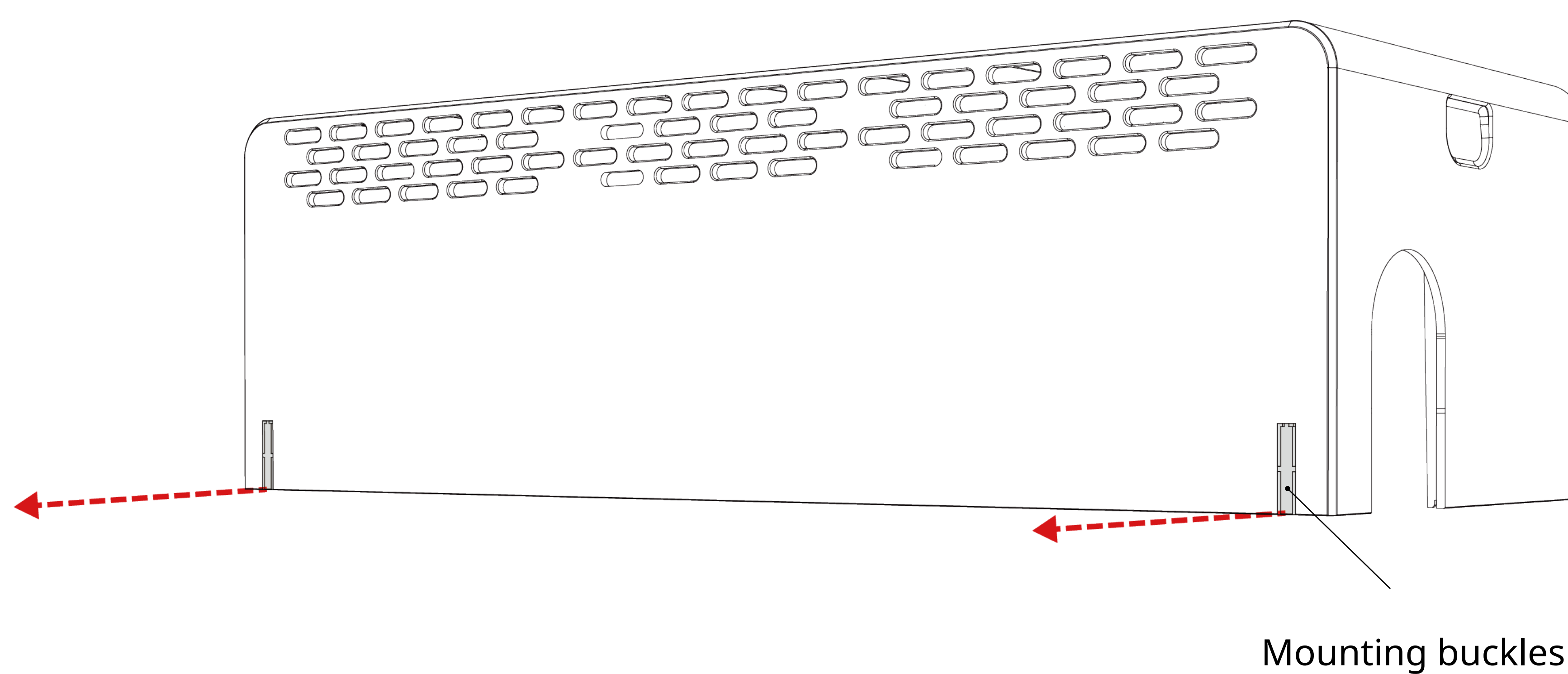

4.10 Power on the system

- a. Use the multimeter to measure the voltage between the N pole and L1 pole (or L2 pole, L3 pole). The voltage value should be approximately the nominal phase voltage, e.g. 220 V, 230 V and 240 V.
- b. Switch on the battery breaker in the combiner and power on the system.

4.11 Activate the system

- a. Log in to the ATMOZEN APP on your mobile phone and follow the deployment guide in the app to activate the system.
- b. After the system is activated, the SOC status LED will be solid blue.

4.12 System level Battery Parameter Settings

- Find number of batteries.
- Mark the square box on the single-phase/three-phase system nameplate.
- Open and Login Atmozen App.
- Click "Local Access" on Menu.
- On "Local Access" page, click on "Parameters".
- Under "Configuration Parameters" page, click on "Battery Parameters".
- Modify "Charging Power Upper Limit(kW)" and "Discharging Power Upper Limit(kW)" based on Calculation.
- After modification, click on "Apply Now" to save the changes.

NOTE:

- Currently in Australia, maximum output for single-phase is 5KVA, and 15KVA maximum output for three-phase).

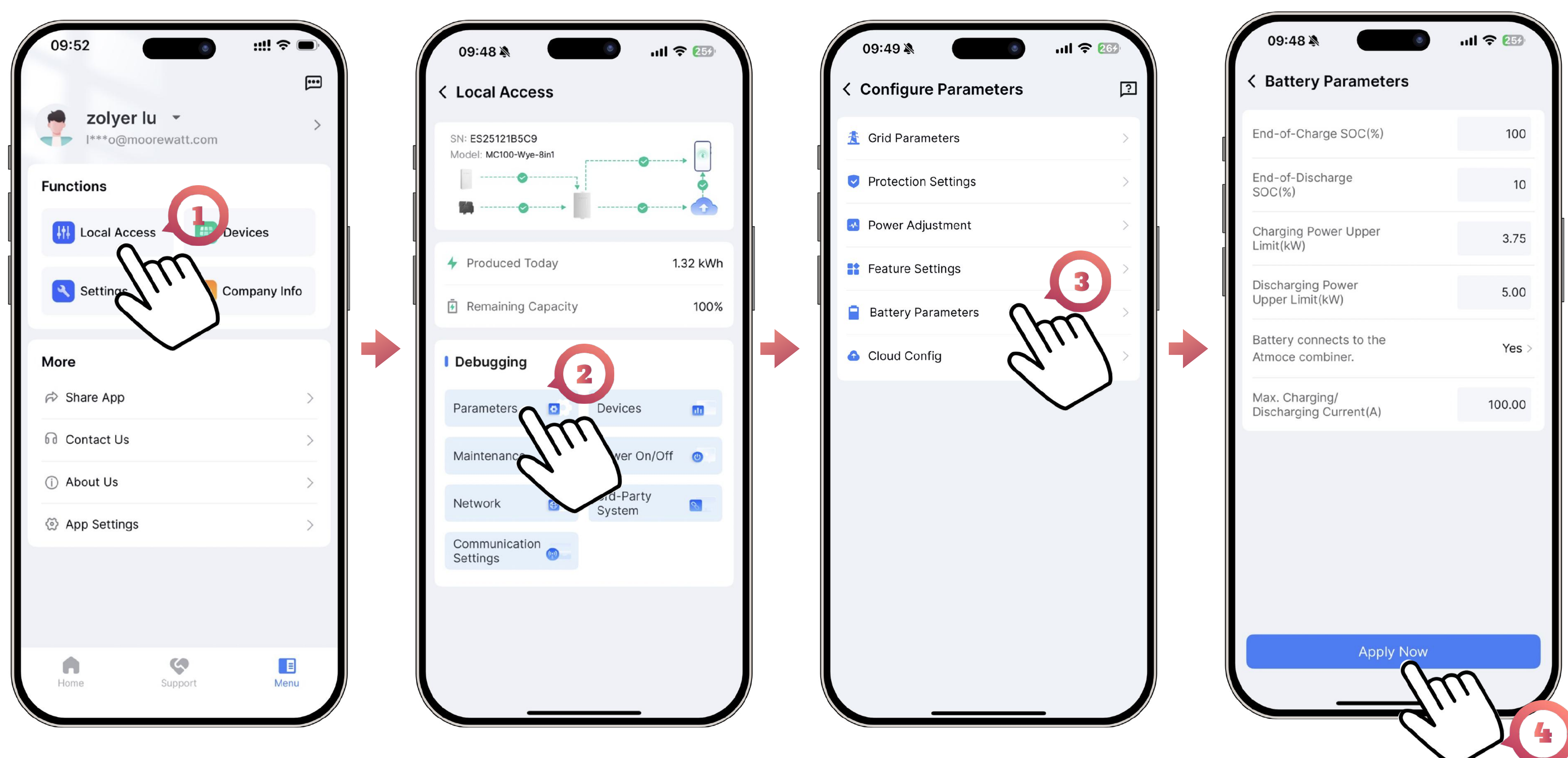

MC100PRO-S1P Installation

5.1 MC100PRO-S1P Introduction

The single-phase M-CombinerPro (MC100PRO-S1P) is an integrated power management device for single-phase grid systems. It connects microinverters, batteries, and loads, enabling efficient energy distribution and grid interaction. With a built-in M-Gateway (MG100) smart controller, it manages solar production, battery storage, and power consumption. The system automatically switches between grid-connected and backup modes—using solar power to feed the grid or charge batteries during normal operation, and providing instant off-grid backup during outages. Users can monitor and optimize energy usage in real-time via the ATMOCE-Cloud and ATMOZEN APP. The MC100PRO-S1P offers enhanced safety, energy independence, and reliable performance in all conditions.

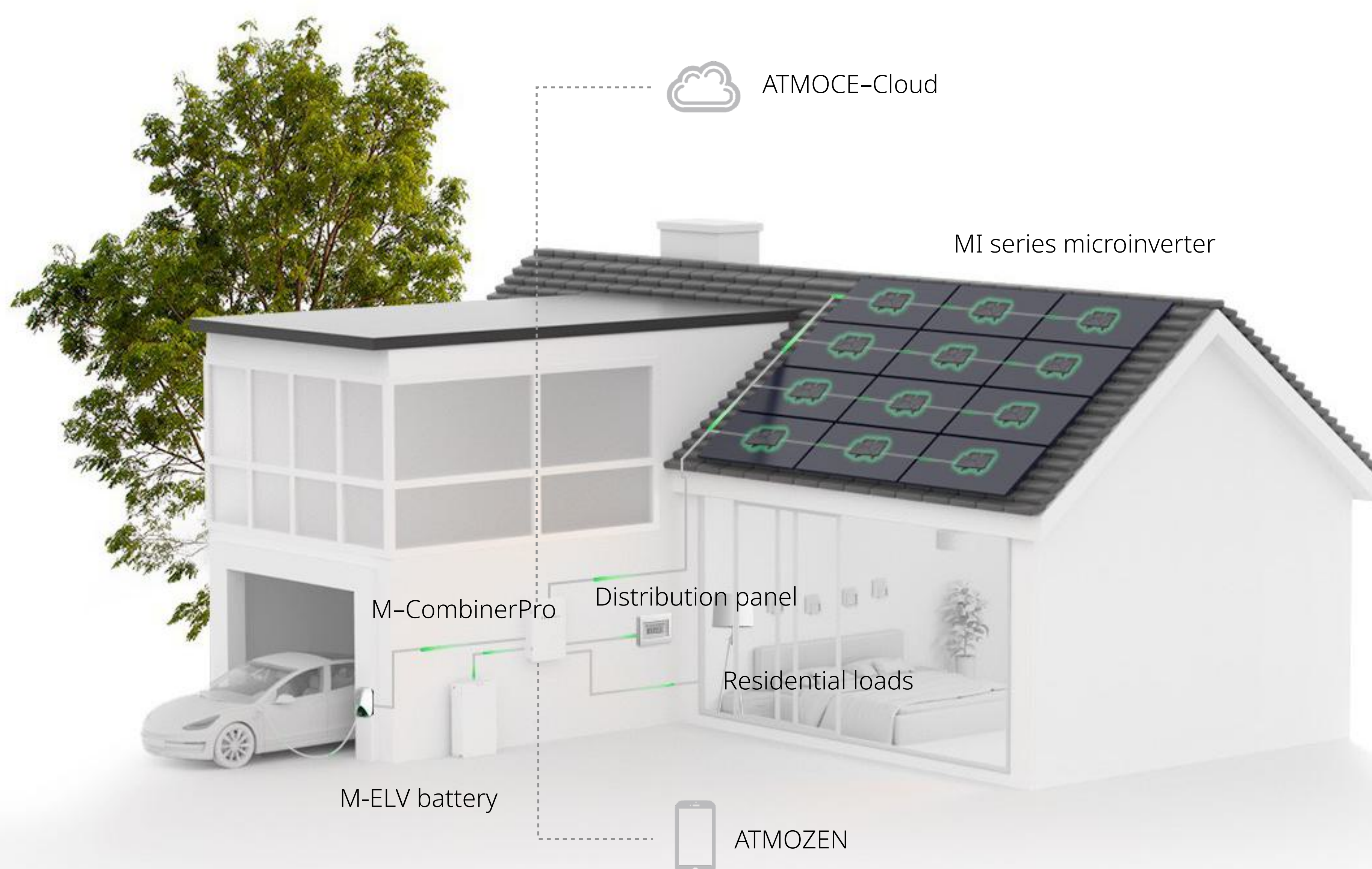

5.2 Pre-installation Requirements

5.2.1 What's in the MC100PRO-S1P

Refer to the figure on the right for pre-installed components in the MC100PRO-S1P.

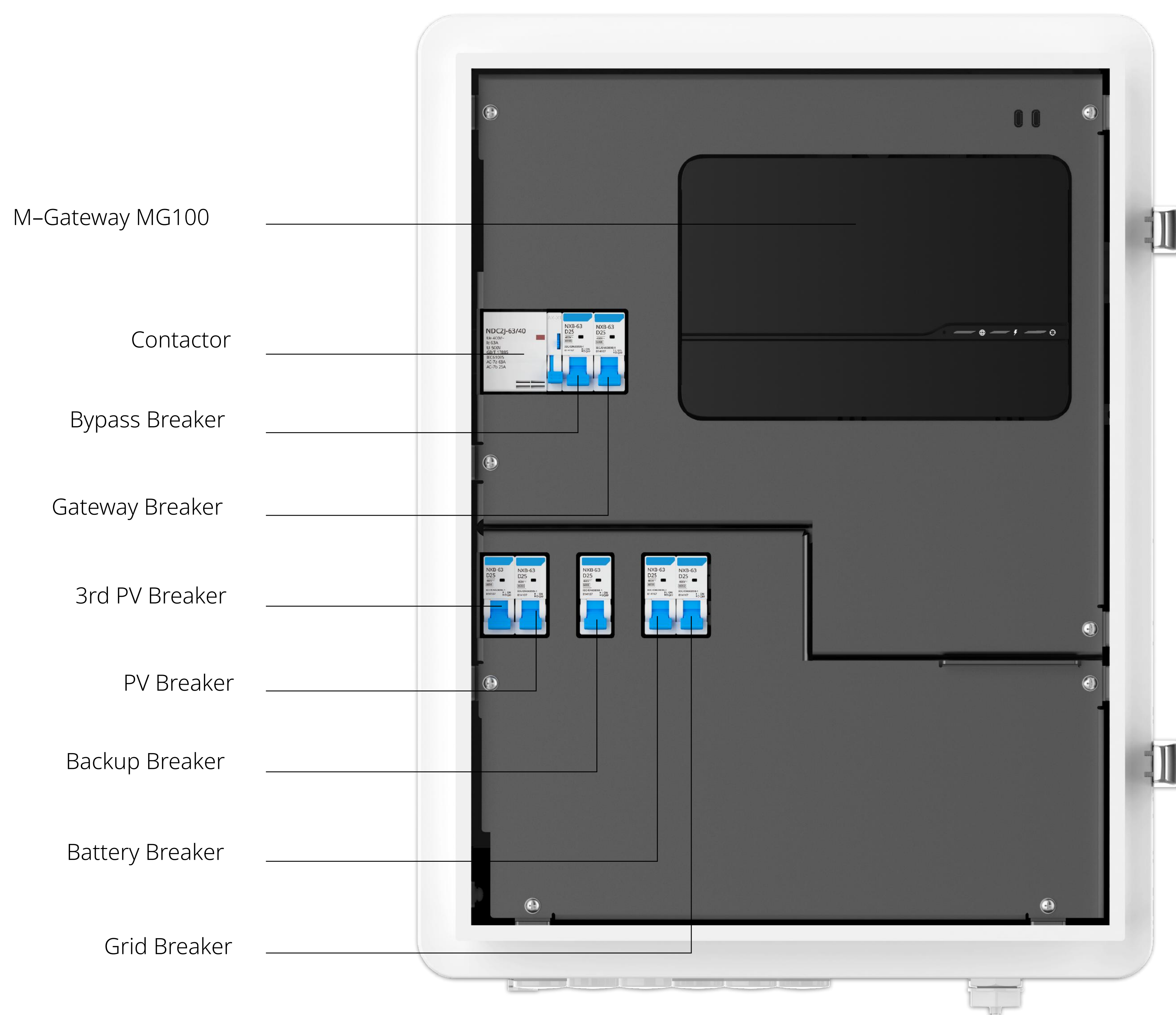

5.2.2 Check the grid voltage

The MC100PRO-S1P should connect to a Single-phase grid. Measure the AC voltage at the point of connection to confirm that it is within the range.

Phase setup	Voltage range
Single-phase	L to N 176 to 276 Vac

5.2.3 Prepare the cables

To properly set up the system, it is necessary to select the appropriate cables. The table below shows the recommended cable requirements.

Connection	Recommendation
PV / 3rd Party PV	Power cable 2.5 to 16 mm ² , 3-core
Backup / Grid / Non-Backup	Power cable 2.5 to 16 mm ² , 3-core
Battery	Power cable 2.5 to 16 mm ² , 3-core CAN cable 0.25 to 0.75 mm ² , 3-core
Device	Control cable 0.25 to 0.75 mm ² , 2-core ETH cable 802.3, Cat 6 UTP ethernet cable

NOTE:

- When stripping the cable, remove approximately 12 mm of the insulation layer from the power cable and 8mm of insulation layer from the communication cable.

NOTE:

- The recommended wire size connected to the battery are as below:

Number of units	Maximum current	Recommended wire size	Notes
1	23.8	4 mm ²	/
2	47.6	10 mm ²	/
3	50	10 mm ²	Software limit for maximum current
4	50	10 mm ²	Software limit for maximum current
5	50	10 mm ²	Software limit for maximum current
6	50	10 mm ²	Software limit for maximum current

5.2.4 Prepare the tools and materials

Tools: screwdriver, wire stripper, wire crimper, diagonal cutter, torque wrench, electrical drill, hole cutter with pilot, tape measure, multimeter, marker, etc.

Materials: wall anchors ($\Phi 10$) and screws (M8), corrugated protective pipe, cold-press terminal, tie wrap, etc.

5.2.5 Select how the device connects to the Internet

You can connect the combiner to the Internet through Wi-Fi and Ethernet.

- Ethernet connection: please use 802.3, Cat 6 UTP ethernet cable.
- Wi-Fi connection: install the M-CombinerPro within 10 meters from the router to ensure stable Wi-Fi signal.

5.2.6 Download the ATMOZEN APP

You can download the app from Google Play or Apple App Store.



5.3 Mount the M-CombinerPro

- Use a tape measure to locate the marking board on the wall. It should be at least 600 mm vertically from the floor.
- Use the spirit level to check that the board is level, then make three marks on the wall.
- Drill at the three marks by using an electric drill with a bit ($\Phi 10$).
- Insert the wall anchors (along with the guide) into the holes, and then insert the M8 screw into the TOP holes. Do not completely tighten it.
- Fix the rail on the two top screws.
- Hang the top two hangers of the cabinet in the corresponding position of the rail.
- Use the screw to fix the bottom hanger on the wall in the end.

NOTE:

- Do not expose the M-CombinerPro to direct sunlight, unless installing a sunshade.
- The signal cable of the consumption CT is 5 meters long. Therefore the M-CombinerPro must be installed closed to the distribution panel.

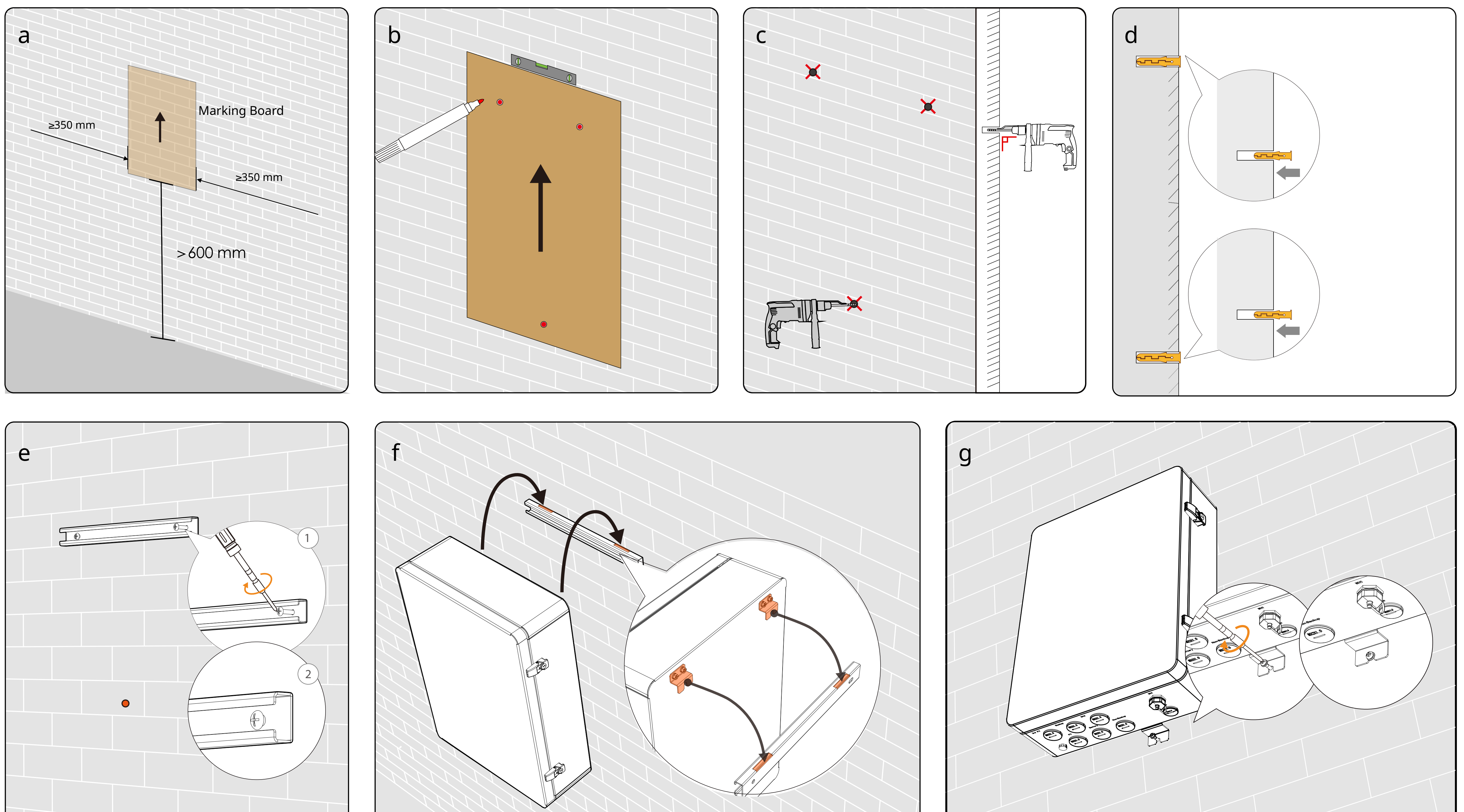

5.4 Remove the protective panel

- a. Open the cabinet door.
- b. Use a Philips 2# screwdriver to remove the protective panel.

NOTE:

- If not necessary or if no meter connection is required, the top cover should not be removed.

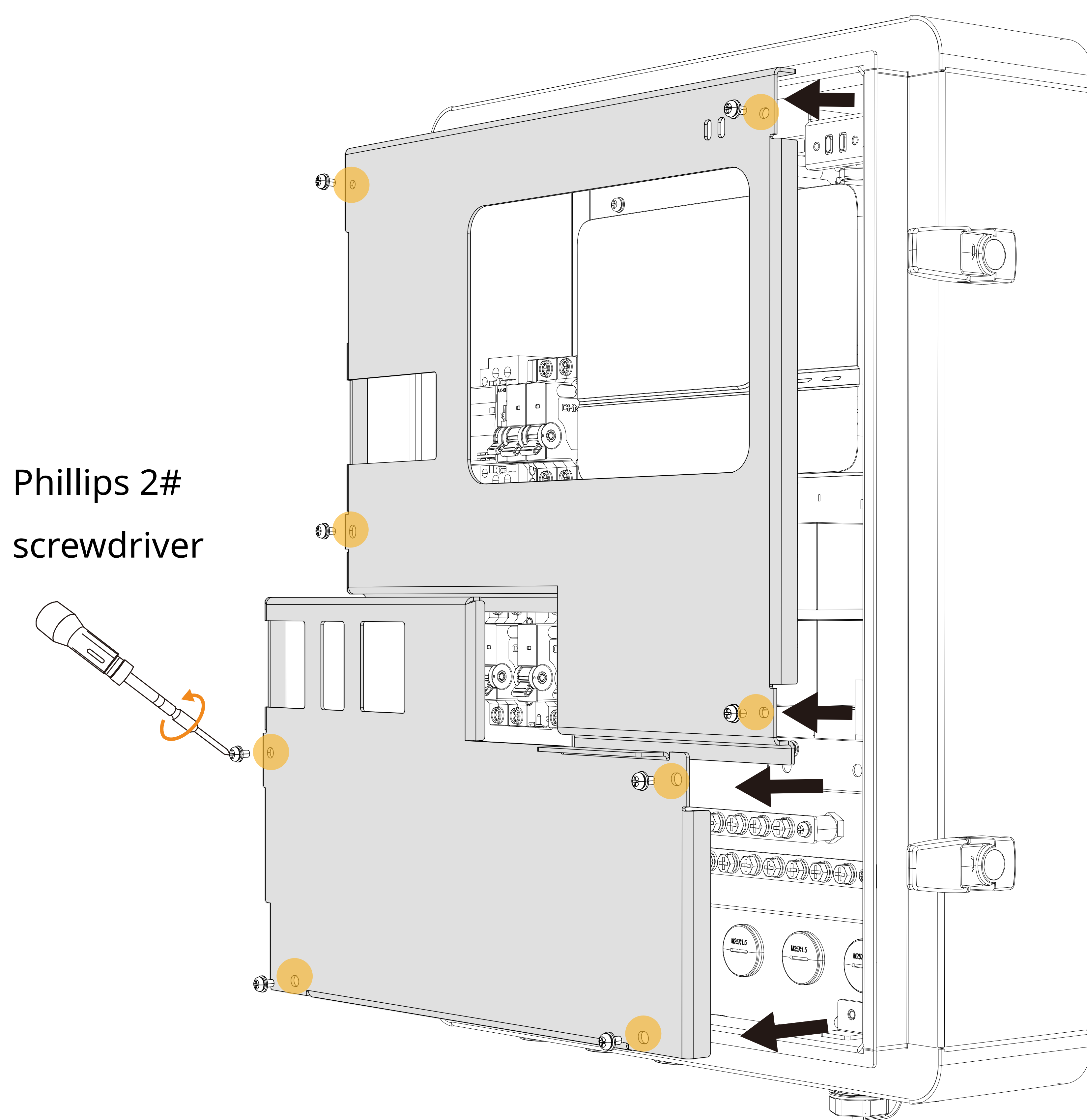

5.5 Wire to the M-CombinerPro

NOTE:

- Regardless of whether it is grid-connected or off-grid, the permanent connection of the battery N line is achieved via connection to the N terminal strip of the CombinerPro.

5.5.1 Wire from the 3rd PV branch

- Bring in the cables from the PV branch circuit through the PV hole of the cabinet.
- Connect the L cable to the PV breakers. Connect the N cable to the N terminal block in MC100PRO-S1P.
- Tighten the screws by using a Phillips #2 screwdriver with a torque of 2–2.5 N·m.
- Optional: Connect the PE cable from the PV rack system to the PE terminal block in MC100PRO-S1P.

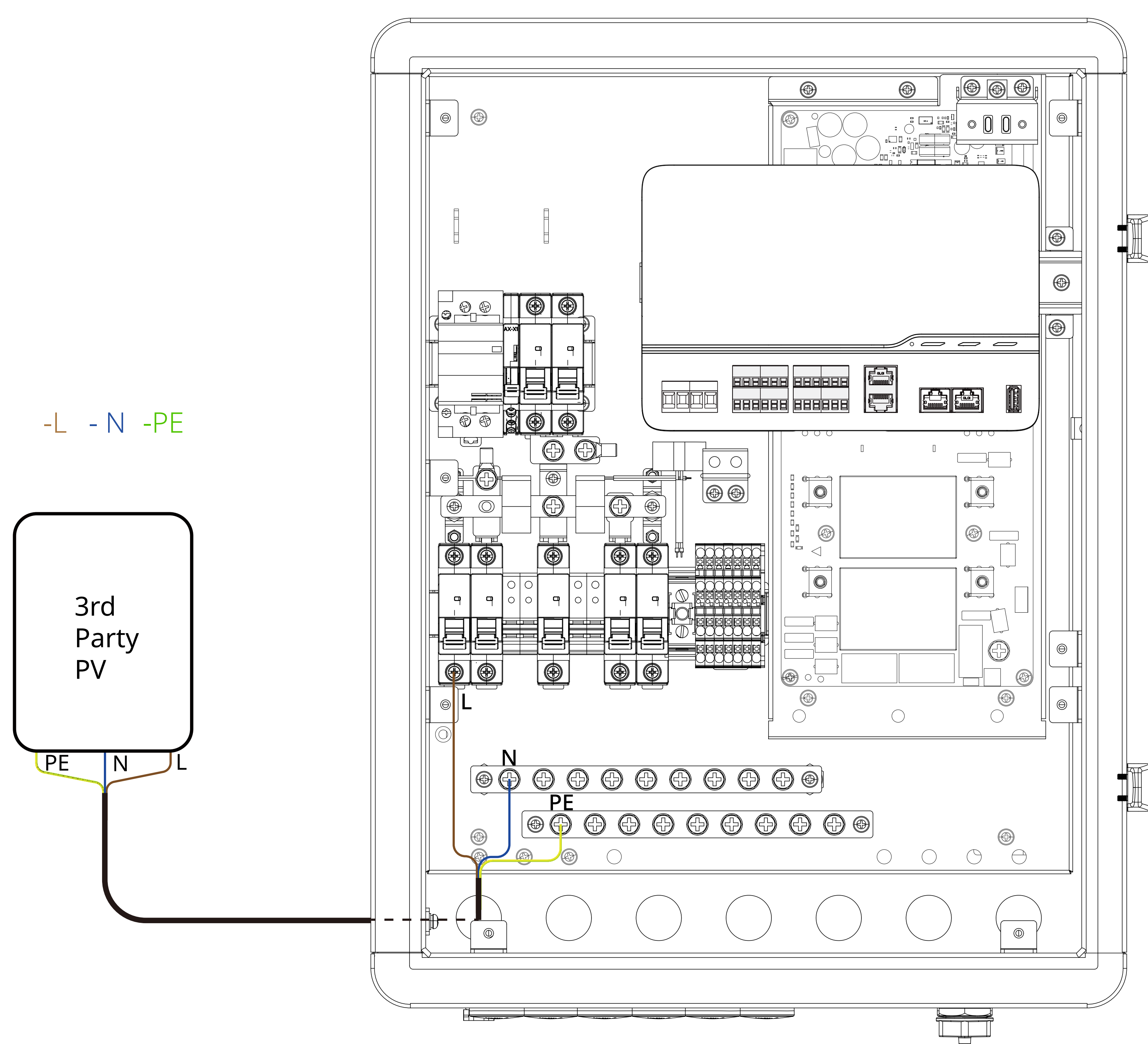

5.5.2 Wire from the PV branch (microinverter)

- Bring in the cables from the PV branch circuit through the PV hole of the cabinet.
- Connect the L cable to the PV breakers. Connect the N cable to the N terminal block in MC100PRO-S1P.
- Tighten the screws by using a Phillips #2 screwdriver with a torque of 2–2.5 N·m.
- Optional: Connect the PE cable from the PV rack system to the PE terminal block in MC100PRO-S1P.

NOTE:

- M-Relay must be installed in the Combiner above.

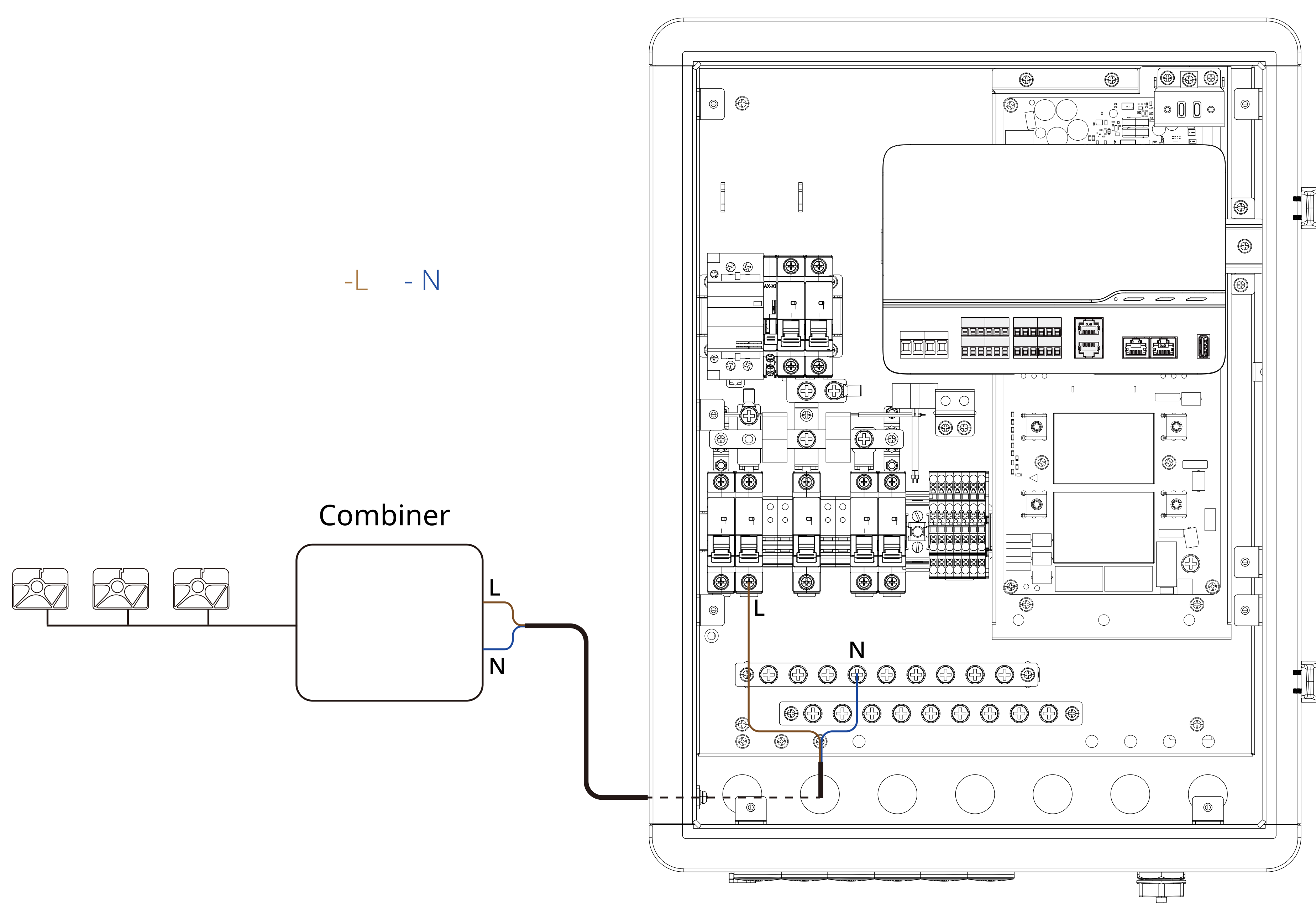

5.5.3 Wire from the Backup

- Bring in the cables from the distribution panel through the Backup hole of the cabinet.
- Connect the L cable to the Backup breakers. Connect the N cable to the N terminal block.
- Connect the PE cable from the Distribution Panel to the PE terminal block in MC100PRO-S1P.
- Tighten the screws by using a Phillips #2 screwdriver with a torque of 2–2.5 N·m.

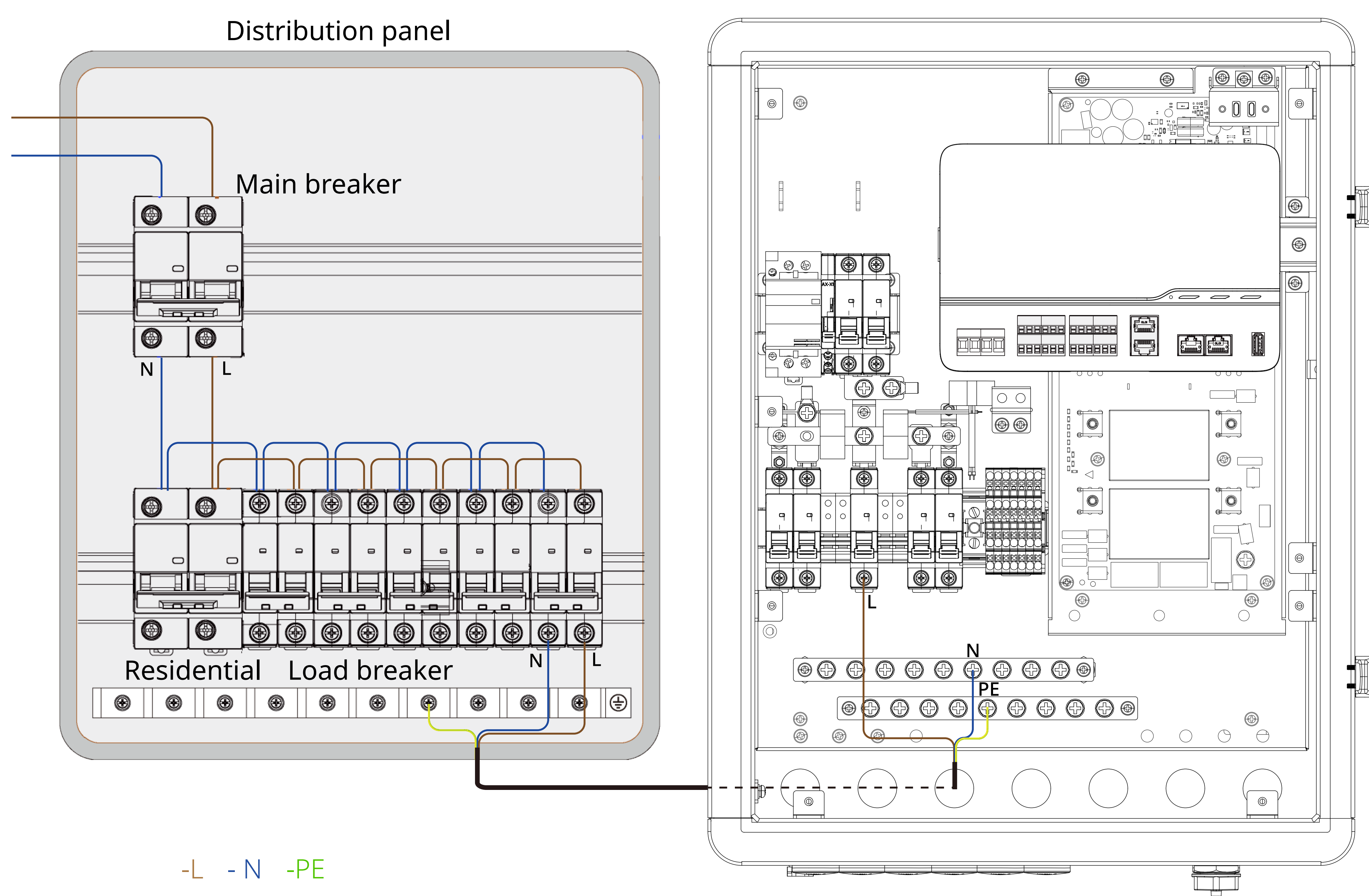

NOTE:

- The recommended rated residual current for compatible RCDs is greater than 100mA, with 30mA being the minimum acceptable threshold. A residual current device RCD type A can be used. Additionally, the maximum current-carrying capacity of the RCD should match the parameters of the grid-side breaker within the CombinerPro.

5.5.4 Wire from the Grid

- Bring in the cables from the grid through the grid hole of the cabinet.
- Connect the L cable to the grid breaker, and connect the ground cable to the PE terminal block as shown. Connect the N cable to the N terminal block.
- Tighten the screws by using a Phillips #2 screwdriver with a torque of 3.5–4 N·m.

NOTE:

- The consumption CTs are already built-in.

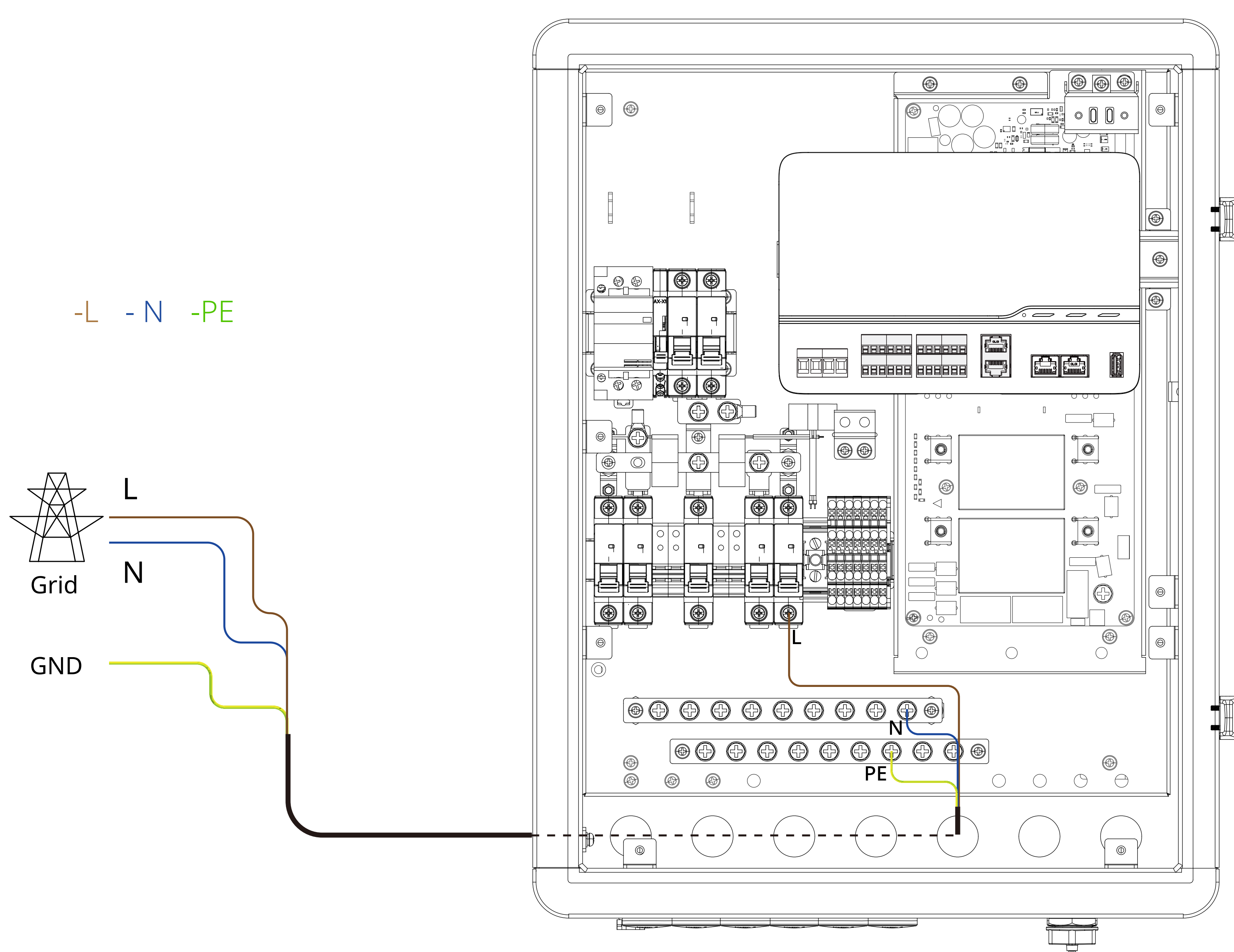

NOTE:

- The recommended rated residual current for compatible RCDs is greater than 100mA, with 30mA being the minimum acceptable threshold. A residual current device RCD type A can be used. Additionally, the maximum current-carrying capacity of the RCD should match the parameters of the grid-side breaker within the CombinerPro.

5.5.5 (Optional) Wire from the battery

- Bring in the cables from the battery through the battery hole of the cabinet.
- Connect the L cable to the battery breaker and connect the ground cable to the PE terminal block as shown. Connect the N cable to the N terminal block.
- Tighten the screws by using a Phillips #2 screwdriver with a torque of 2–2.5 N·m.
- Connect the CAN COM cable of the battery to the terminal as shown in the right figure.

NOTE:

- The Communication interface information could be found in 3.7.

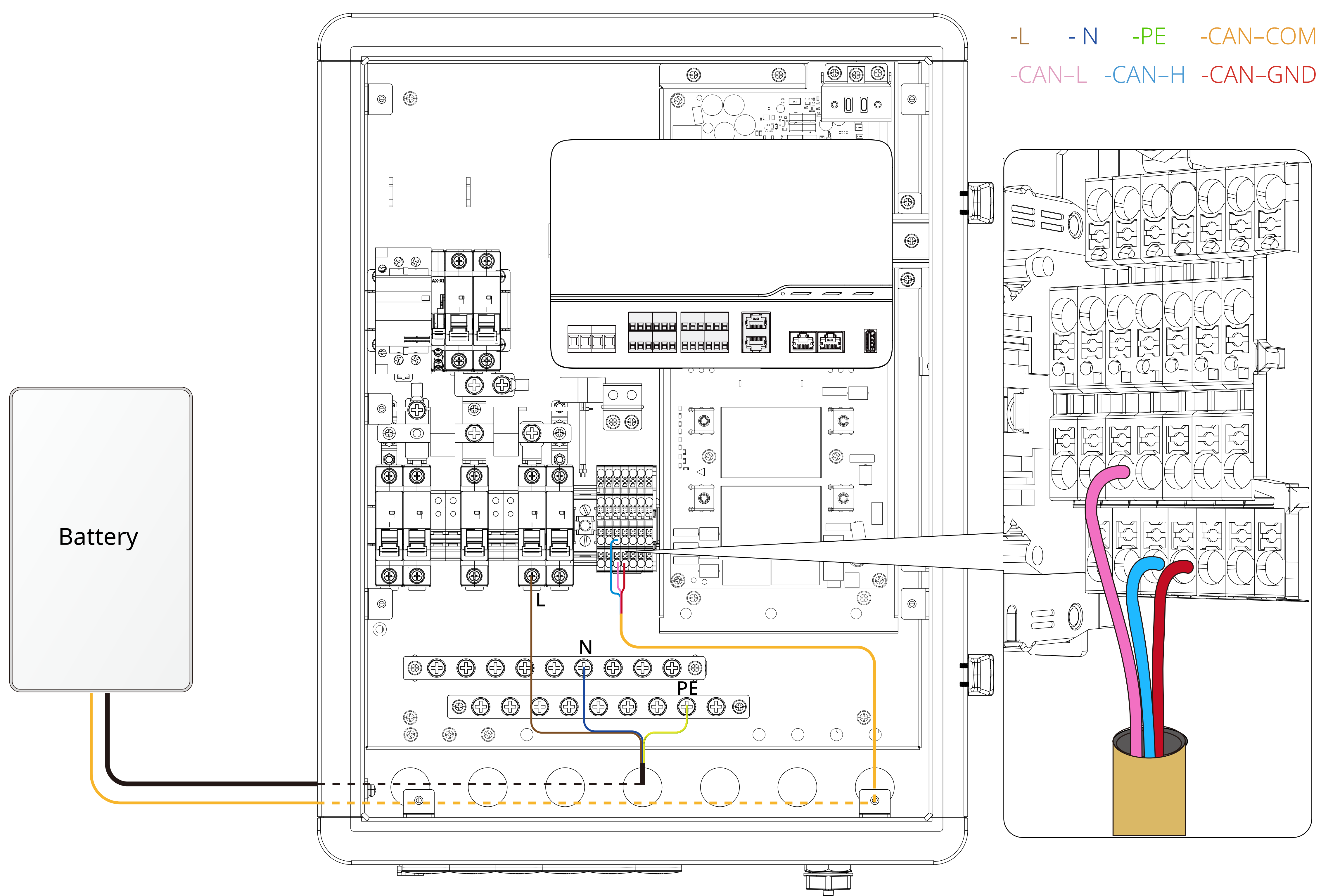

5.5.6 (Optional) Wire from the router

- When you use ETH to connect to Atmoce-Cloud, bring in the cable from the home broadband router through the COM hole of the cabinet.
- Connect the 802.3 Cat 6 UTP ethernet cable to the RJ45 terminal in the cabinet as shown in the figure.

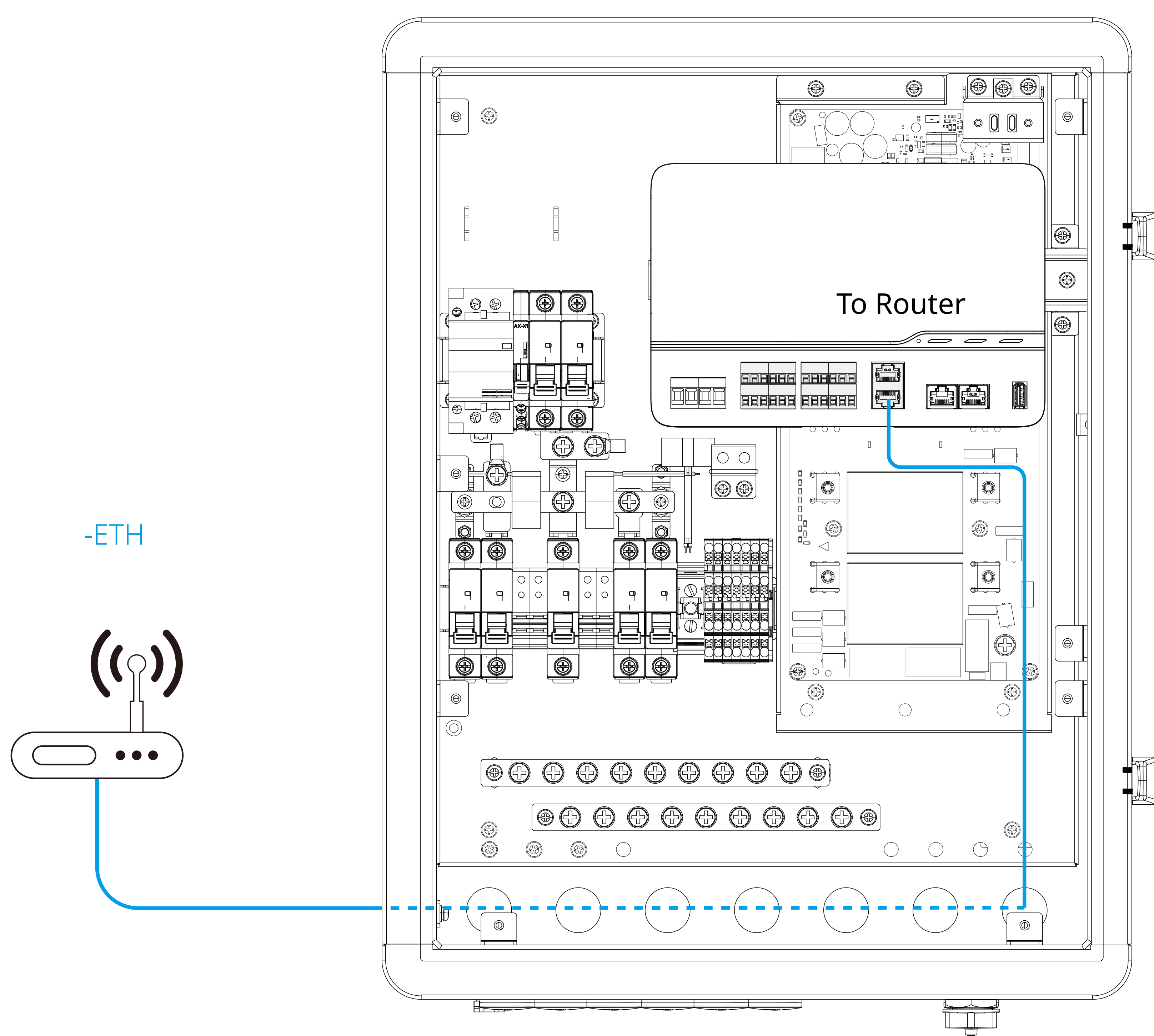

5.5.7 (Optional) Communication interface

- a. The MC100PRO-S1P supports ETH, RS485 and DO CTRL interfaces, etc. Connect the cables from the devices to the communication terminal block as the wire diagram in the cabinet. Bring in the cable from COM hole is recommended.

NOTE:

- M-Gateway supports more flexible and smart control by integrated communication interfaces. Refer to "M-Gateway User Manual" for more information.

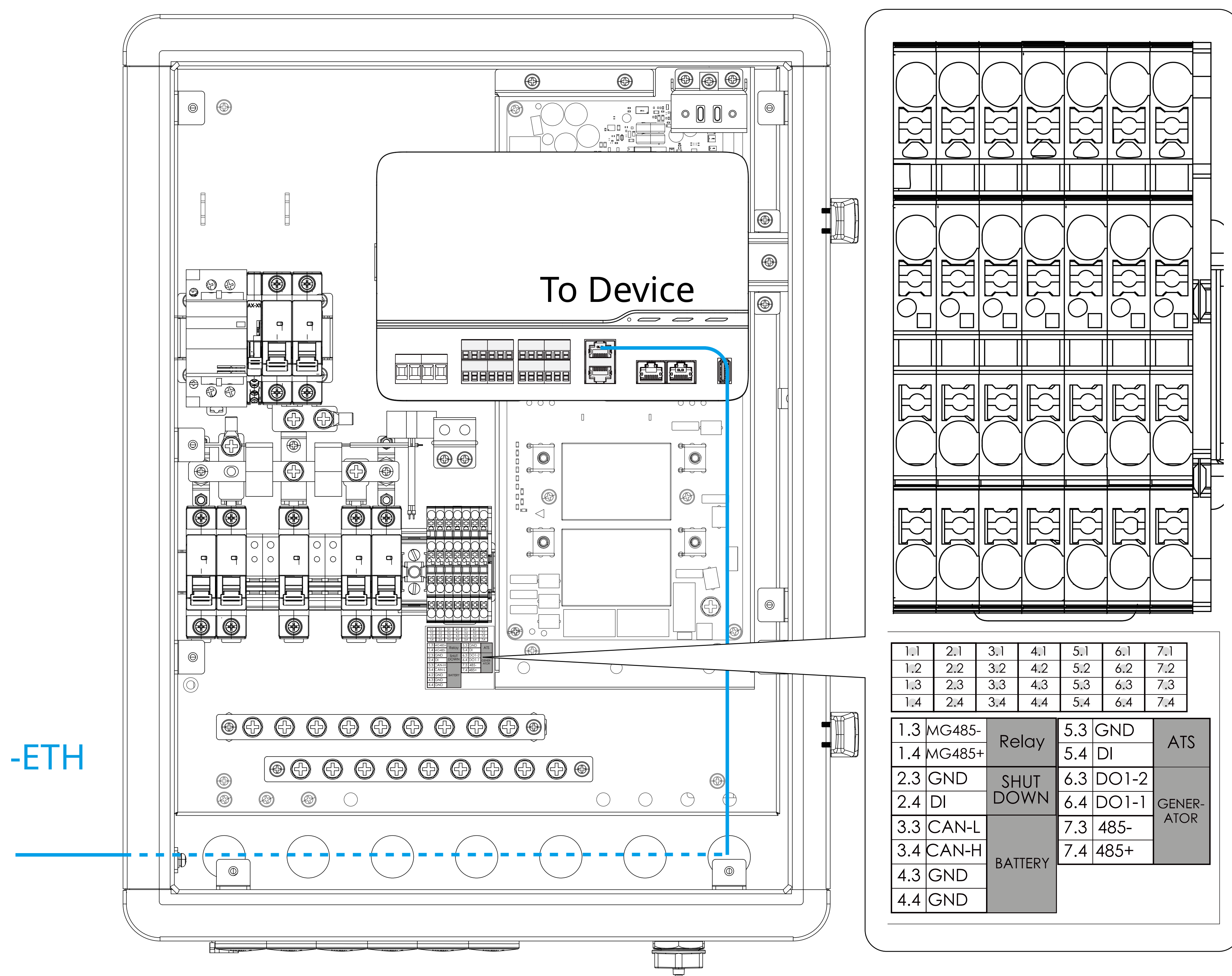

5.5.8 (Optional) Wire from Non Backup Load

- Bring in the cable from the Non Backup Load through the Load hole of the cabinet.
- Connect the L cable to the Non Backup breaker.
- Connect the ground cable to the PE terminal block as shown. Connect the N cable to the N terminal block.

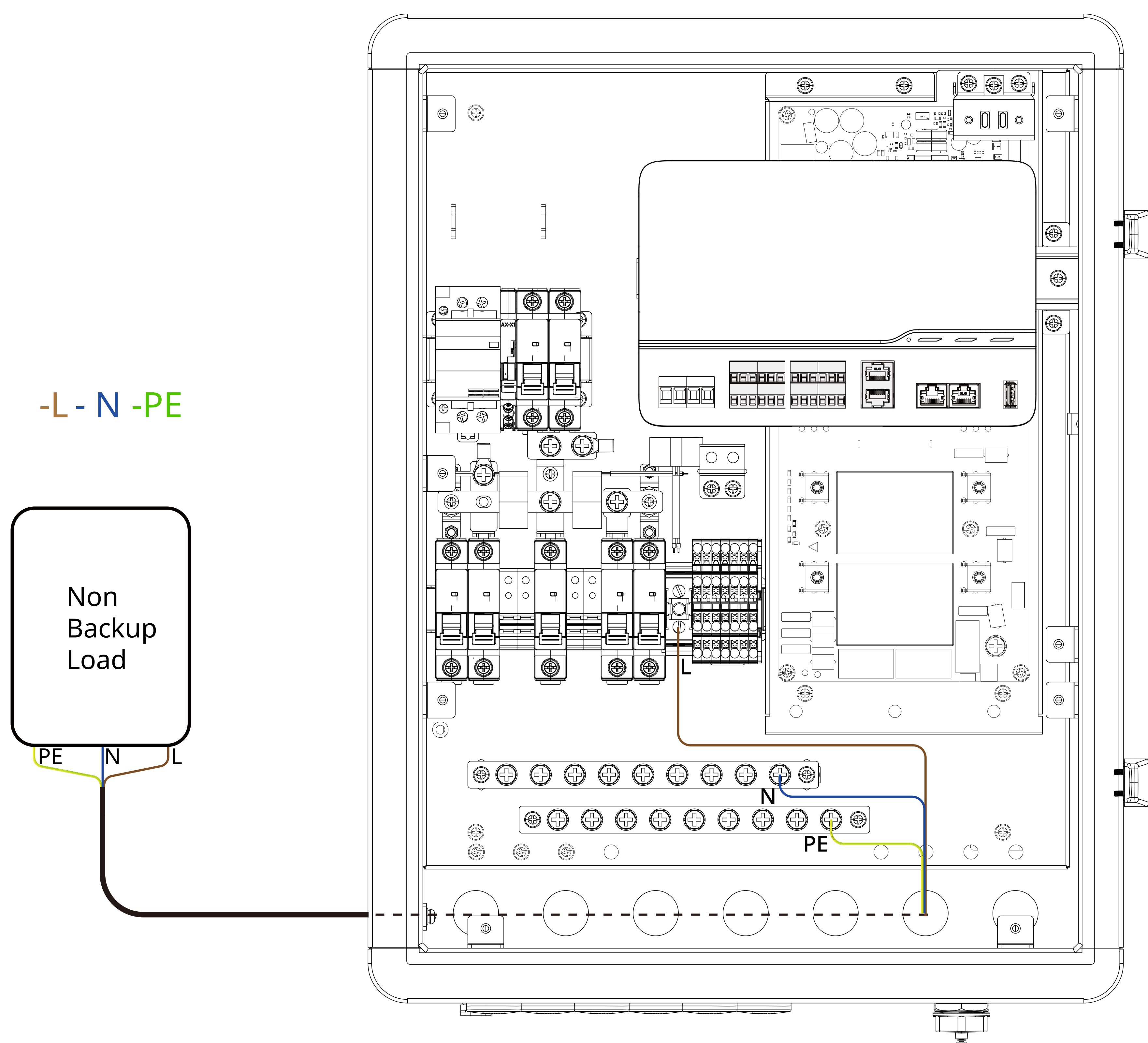

5.5.9 Wifi Dongle connection

- a. Unscrew the cap at the Wifi port on the bottom of the case. Plug in the Wifi Dongle into the Wifi hole.

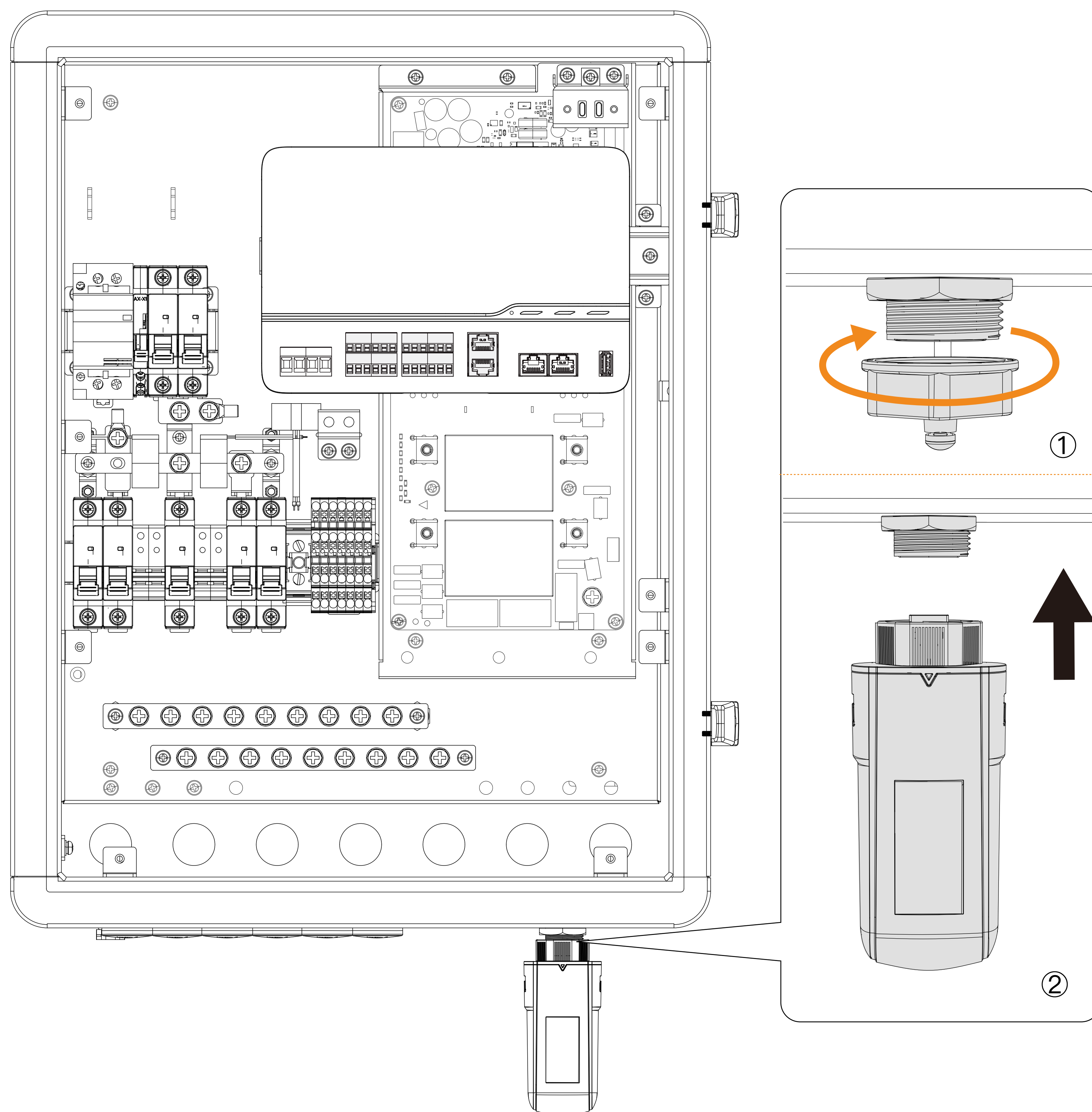

5.6 Power on the system

- Turn on the main breaker and M-CombinerPro breaker in the distribution panel.
- Use the multimeter to measure the voltage between the N pole and L pole of the grid breaker as shown in the figure.
- If the voltage value is approximately the nominal phase voltage, e.g. 220 V, 230 V and 240 V, re-install the protective panel.
- Turn on the grid and other breakers in the combinerPro, and the LEDs on the MG100 will be on.

NOTE:

- If the voltage value is outside the range (184 to 276 V), do not switch on the grid breaker inside the combinerPro. Check the cable connection to avoid damaging the device and voiding the warranty.

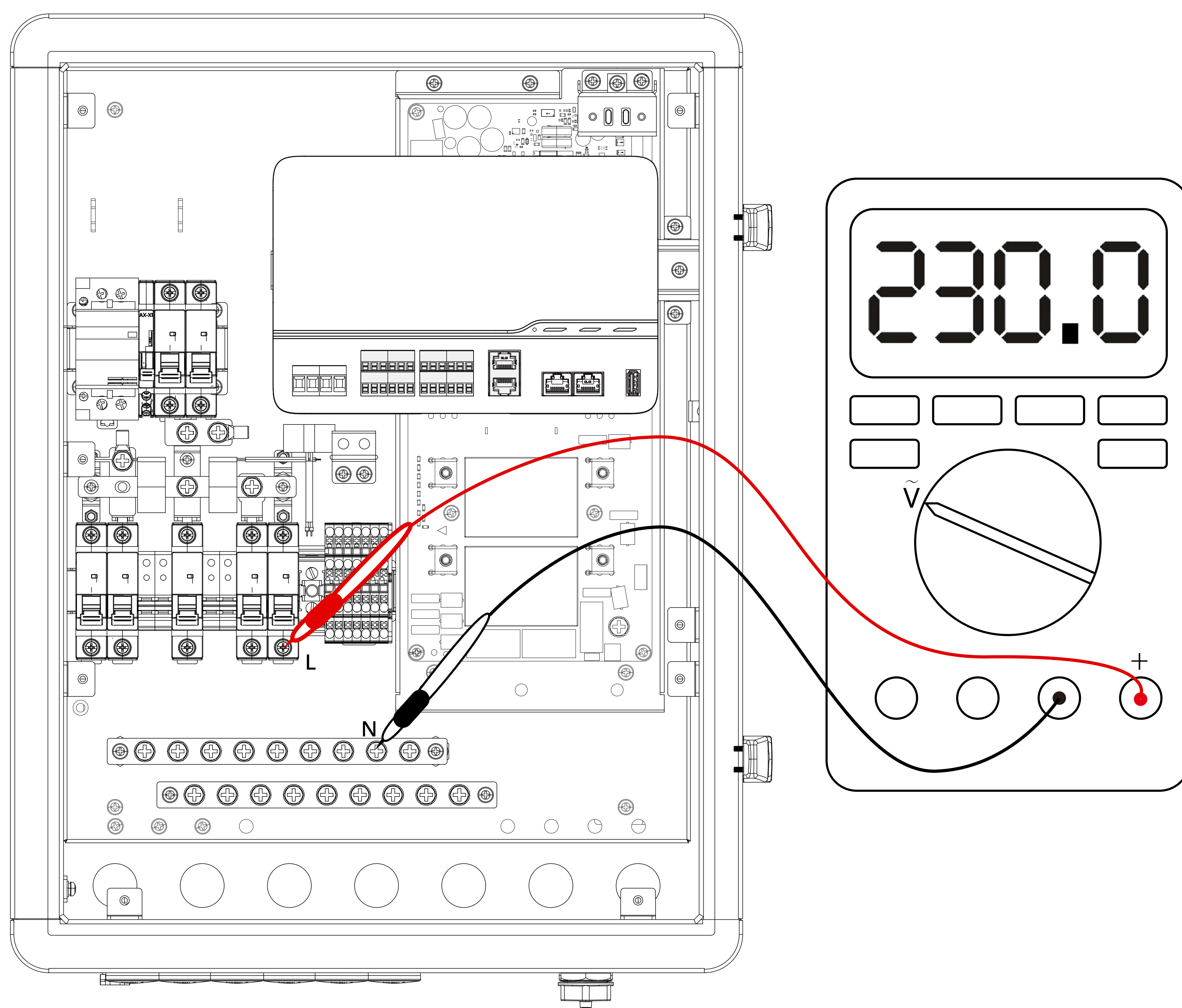

5.7 Activate the system

- Log in to the ATMOZEN APP on your mobile phone and follow the deployment guide in the app to activate the system.
- After the system is activated, all LEDs will be solid green.

5.8 Close the M-CombinerPro

- Close the door of the MC100PRO-S1P.

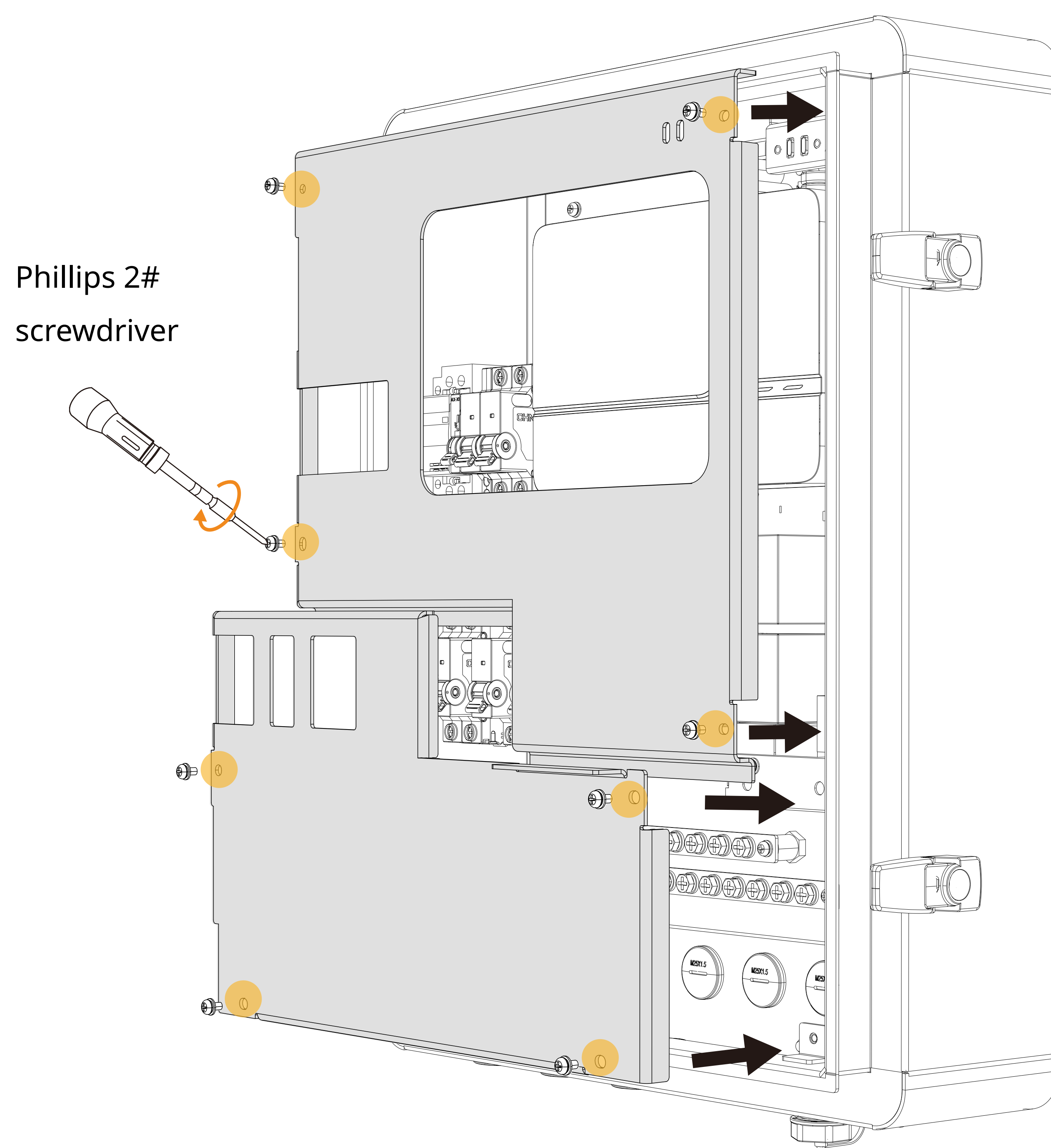

5.9 LED indicator description

a. The above two LEDs reveal the status and mode of the backup part. The left LED represents Status and the right one represents Mode.

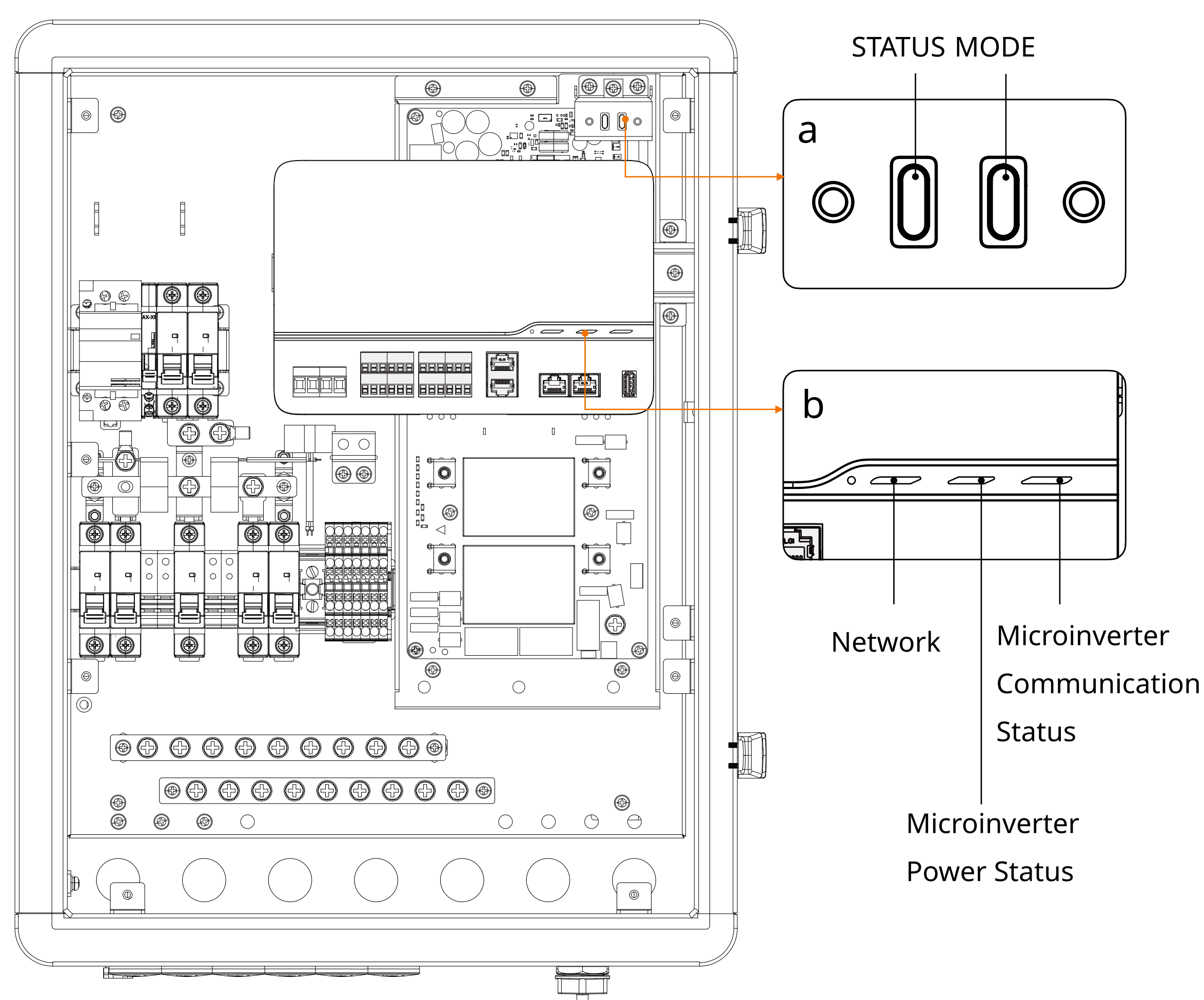

Function	Colour		Description
Status	Solid Green		Normal
	Quick Flash Orange		Upgrading mode
	Slow Flash Red		Communication fault
	Solid Red		System fault
Mode	Solid Green		On-grid mode
	Solid Orange		Off-grid mode
	Slow Flash Green		Generator mode

b. The three LEDs on the Gateway reveal 'Microinverter Communication Status' 'Microinverter Power Status' 'Network' from left to right.

Function	Colour		Description
Network Status	Solid Green		Connecting to cloud.
	Quick Flash Green		Connecting to app via Bluetooth.
	Slow Flash Red		No network available.
Microinverter Power Status	Solid Green		All communicating microinverters are generating power.
	Slow Flash Orange		At least one microinverter is not generating power.
	Dimmed		All microinverters are not generating power.
Microinverter Communication Status	Solid Green		All microinverters are communicating normally.
	Quick Flash Green		The MG100 is detecting microinverters.
	Slow Flash Orange		At least one microinverter is not in communicating.
	Slow Flash Red		All microinverters are not communicating (not due to low light or night time).
	Dimmed		All microinverters are not communicating (due to low light or night time).
ALL	Slow Flash Green		Software update is in progress.

MC100PRO-T3P Installation

6.1 MC100PRO-T3P Introduction

The three-phase M-CombinerPro (MC100PRO-T3P) is an integrated power management device for three-phase grid systems. It connects microinverters, batteries, and loads, enabling efficient energy distribution and grid interaction. With a built-in M-Gateway (MG100) smart controller, it manages solar production, battery storage, and power consumption. The system automatically switches between grid-connected and backup modes—using solar power to feed the grid or charge batteries during normal operation, and providing instant off-grid backup during outages. Users can monitor and optimize energy usage in real-time via the ATMOCE-Cloud and ATMOZEN APP. The MC100PRO-T3P offers enhanced safety, energy independence, and reliable performance in all conditions.

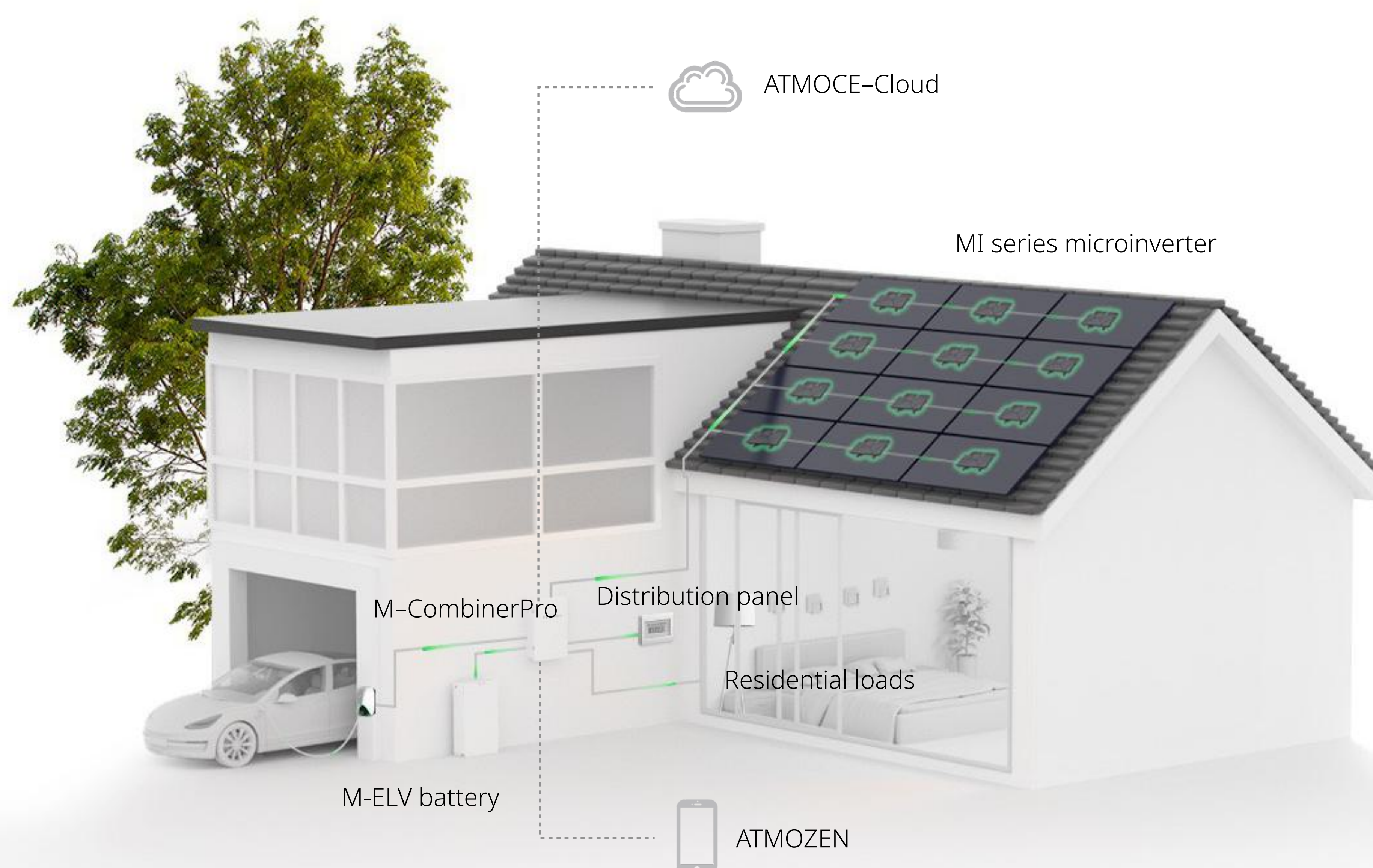

6.2 Pre-installation Requirements

6.2.1 What's in the MC100PRO-T3P

Refer to the figure on the right for pre-installed components in the MC100PRO-T3P.

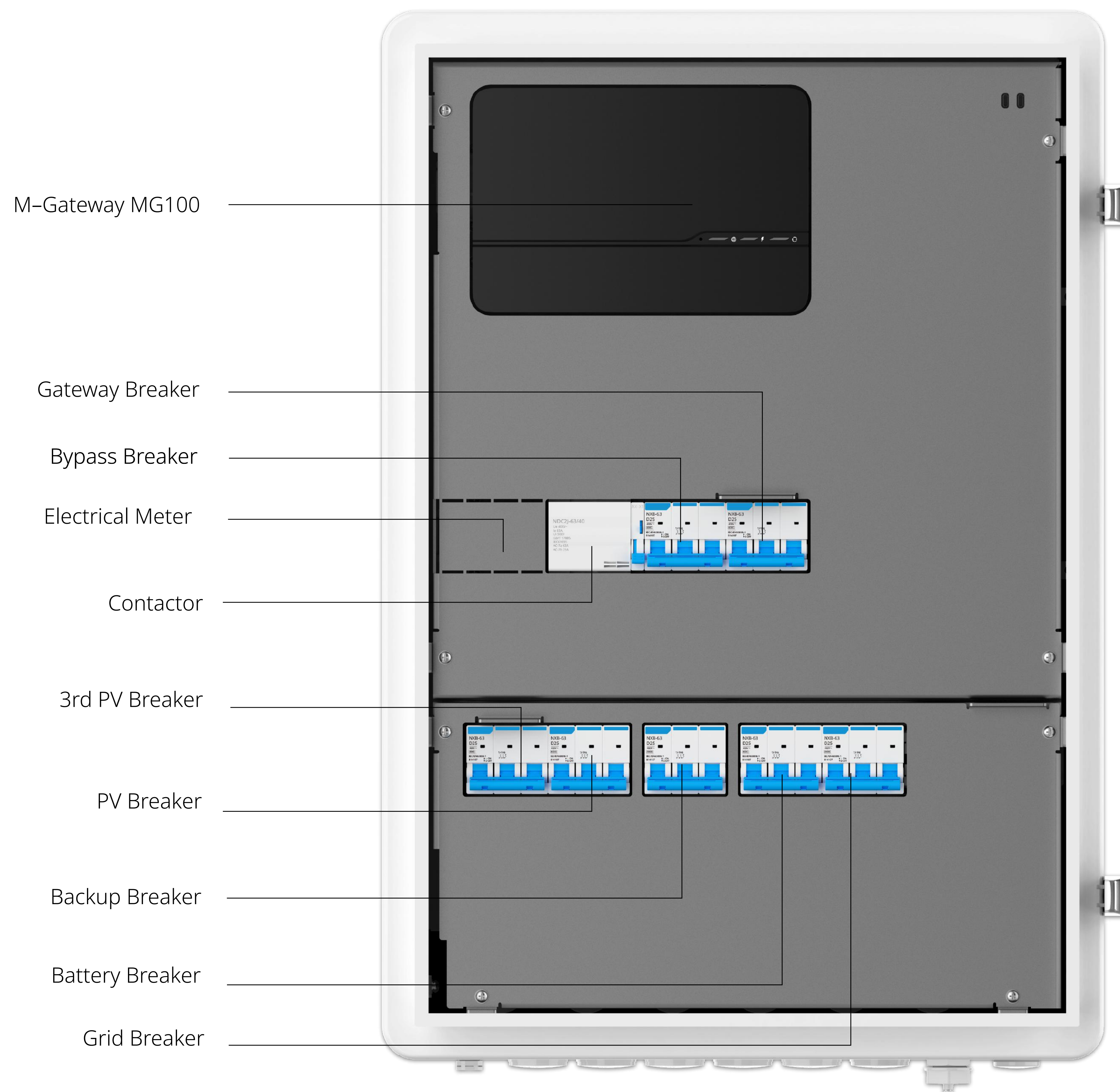

6.2.2 Check the grid voltage

The MC100PRO-T3P should connect to a Three-phase grid. Measure the AC voltage at the point of connection to confirm that it is within the range.

Phase setup	Voltage range	
Three-phase	L1, L2, L3 to N	176 to 276 Vac

6.2.3 Prepare the cables

To properly set up the system, it is necessary to select the appropriate cables. The table below shows the recommended cable requirements.

Connection	Recommendation	
PV / 3rd Party PV	Power cable	2.5 to 16 mm ² , 5-core
Backup / Grid / Non-Backup	Power cable	2.5 to 16 mm ² , 5-core
Battery	Power cable	2.5 to 16 mm ² , 5-core
	CAN cable	0.25 to 0.75 mm ² , 3-core
Device	Control cable	0.25 to 0.75 mm ² , 2-core
	ETH cable	802.3, Cat 6 UTP ethernet cable

NOTE:

- When stripping the cable, remove approximately 12 mm of the insulation layer from the power cable and 8mm of insulation layer from the communication cable.

NOTE:

- The recommended wire size connected to the battery are as below:

Number of units	Maximum current	Recommended wire size	Notes
1	7.9	2.5 mm ²	/
2	15.9	2.5 mm ²	/
3	23.9	4 mm ²	/
4	31.9	6 mm ²	/
5	39.9	10 mm ²	/
6	47.9	10 mm ²	/

6.2.4 Prepare the tools and materials

Tools: screwdriver, wire stripper, wire crimper, diagonal cutter, torque wrench, electrical drill, hole cutter with pilot, tape measure, multimeter, marker, etc.

Materials: wall anchors ($\Phi 10$) and screws (M8), corrugated protective pipe, cold-press terminal, tie wrap, etc.

6.2.5 Select how the device connects to the Internet

You can connect the combiner to the Internet through Wi-Fi and Ethernet.

- Ethernet connection: please use 802.3, Cat 6 UTP ethernet cable.
- Wi-Fi connection: install the M-CombinerPro within 10 meters from the router to ensure stable Wi-Fi signal.

6.2.6 Download the ATMOZEN APP

You can download the app from Google Play or Apple App Store.



6.3 Mount the M-CombinerPro

- Use a tape measure to locate the marking board on the wall. It should be at least 600 mm vertically from the floor.
- Use the spirit level to check that the board is level, then make three marks on the wall.
- Drill at the three marks by using an electric drill with a bit ($\Phi 10$).
- Insert the wall anchors (along with the guide) into the holes, and then insert the M8 screw into the TOP holes. Do not completely tighten it.
- Fix the rail on the two top screws.
- Hang the top two hangers of the cabinet in the corresponding position of the rail.
- Use the screw to fix the bottom hanger on the wall in the end.

NOTE:

- Do not expose the M-CombinerPro to direct sunlight, unless installing a sunshade.
- The signal cable of the consumption CT is 5 meters long. Therefore the M-CombinerPro must be installed closed to the distribution panel.

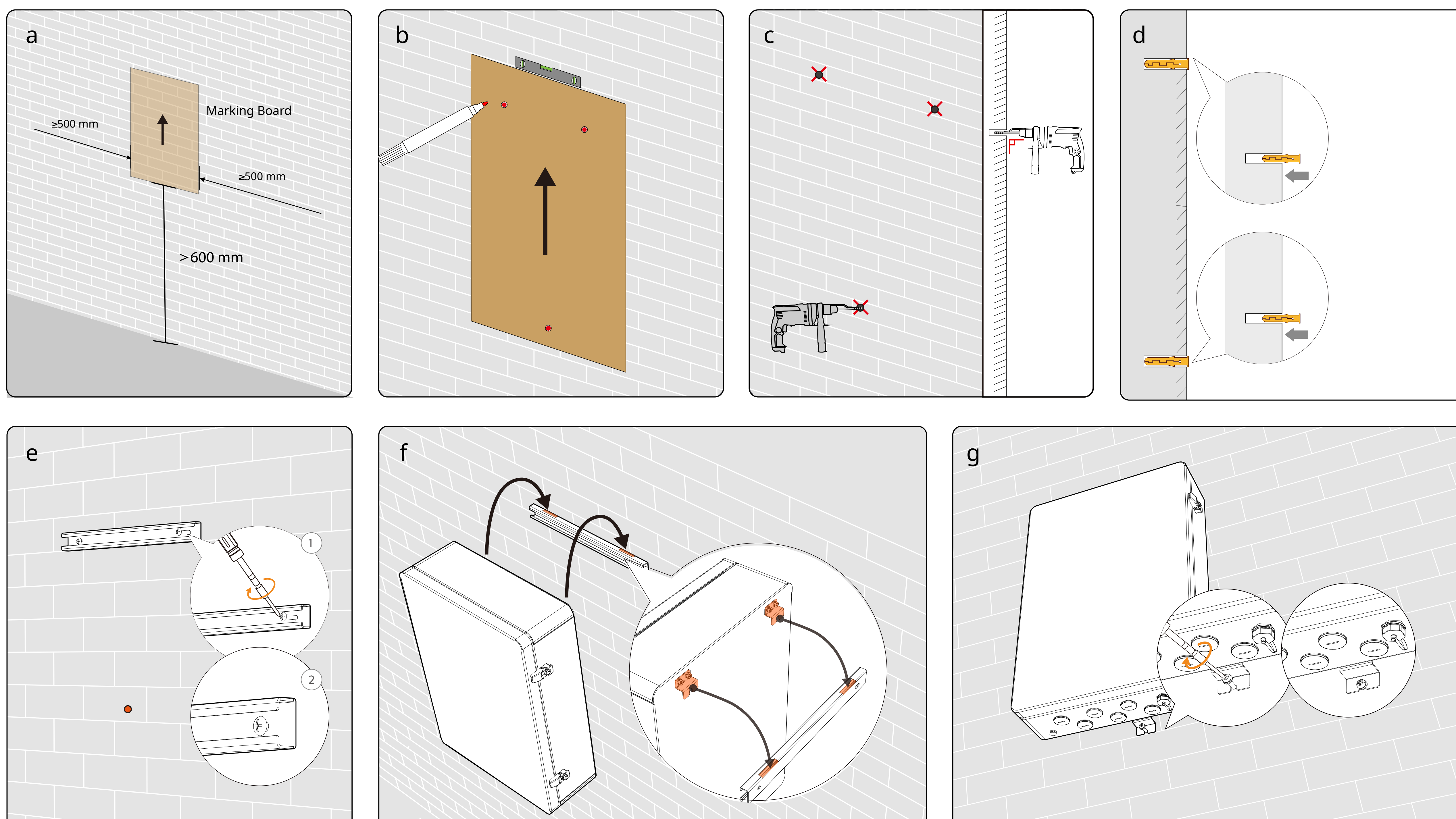

6.4 Remove the protective panel

- Open the cabinet door.
- Use a Phillips 2# screwdriver to remove the protective panel.

NOTE:

- If not necessary or if no meter connection is required, the top cover should not be removed.

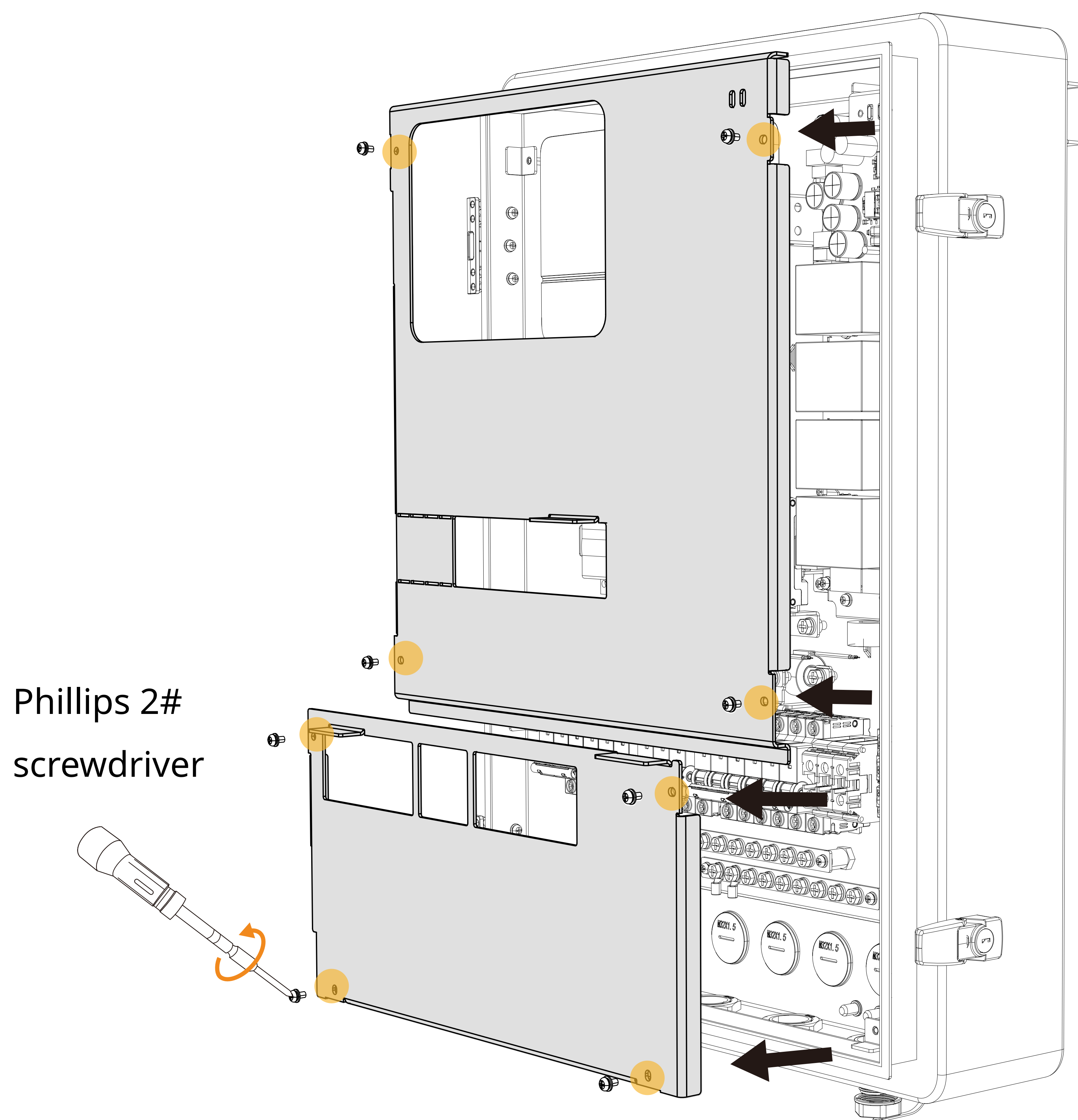

6.5 Wire to the M-CombinerPro

NOTE:

- Regardless of whether it is grid-connected or off-grid, the permanent connection of the battery N line is achieved via connection to the N terminal strip of the CombinerPro.

6.5.1 Wire from the 3rd PV branch

- Bring in the cables from the PV branch circuit through the PV hole of the cabinet.
- Connect the cables (L1 , L2, L3) to the PV breakers. Connect the N cable to the N terminal block in MC100PRO-T3P.
- Tighten the screws by using a Phillips #2 screwdriver with a torque of 2–2.5 N·m.
- Optional: Connect the PE cable from the PV rack system to the PE terminal block in MC100PRO-T3P.

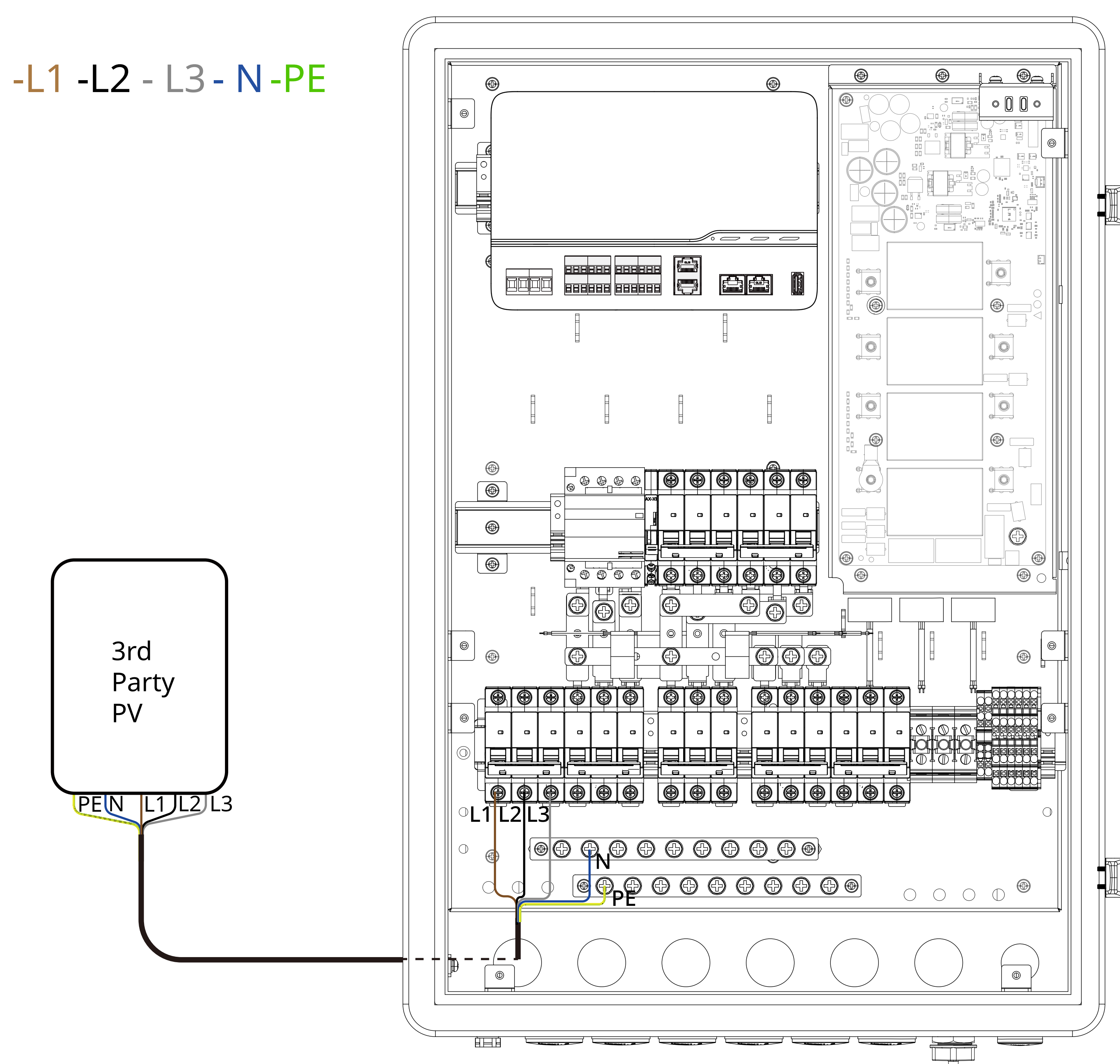

6.5.2 Wire from the PV branch (microinverter)

- Bring in the cables from the PV branch circuit through the PV hole of the cabinet.
- Connect the cables (L1 , L2, L3) to the PV breakers. Connect the N cable to the N terminal block in MC100PRO-T3P.
- Tighten the screws by using a Phillips #2 screwdriver with a torque of 2–2.5 N·m.
- Optional: Connect the PE cable from the PV rack system to the PE terminal block in MC100PRO-T3P.

NOTE:

- M-Relay must be installed in the Combiner above.

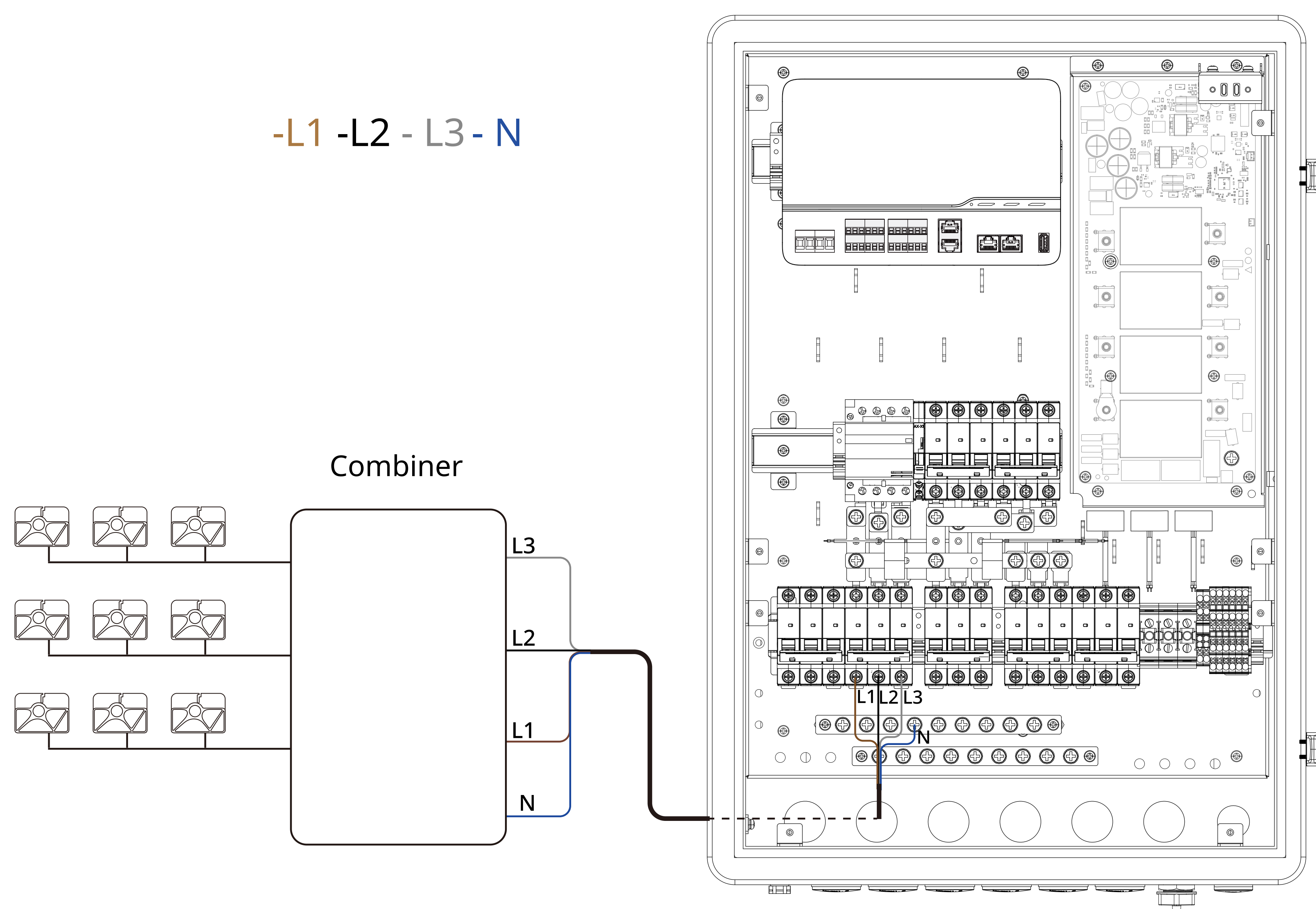

6.5.3 Wire from the Backup

- Bring in the cables from the distribution panel through the Backup hole of the cabinet.
- Connect the cables (L1, L2, L3) to the Backup breakers. Connect the N cable to the N terminal block.
- Connect the PE cable from the Distribution Panel to the PE terminal block in MC100PRO-T3P.
- Tighten the screws by using a Phillips #2 screwdriver with a torque of 2–2.5 N·m.

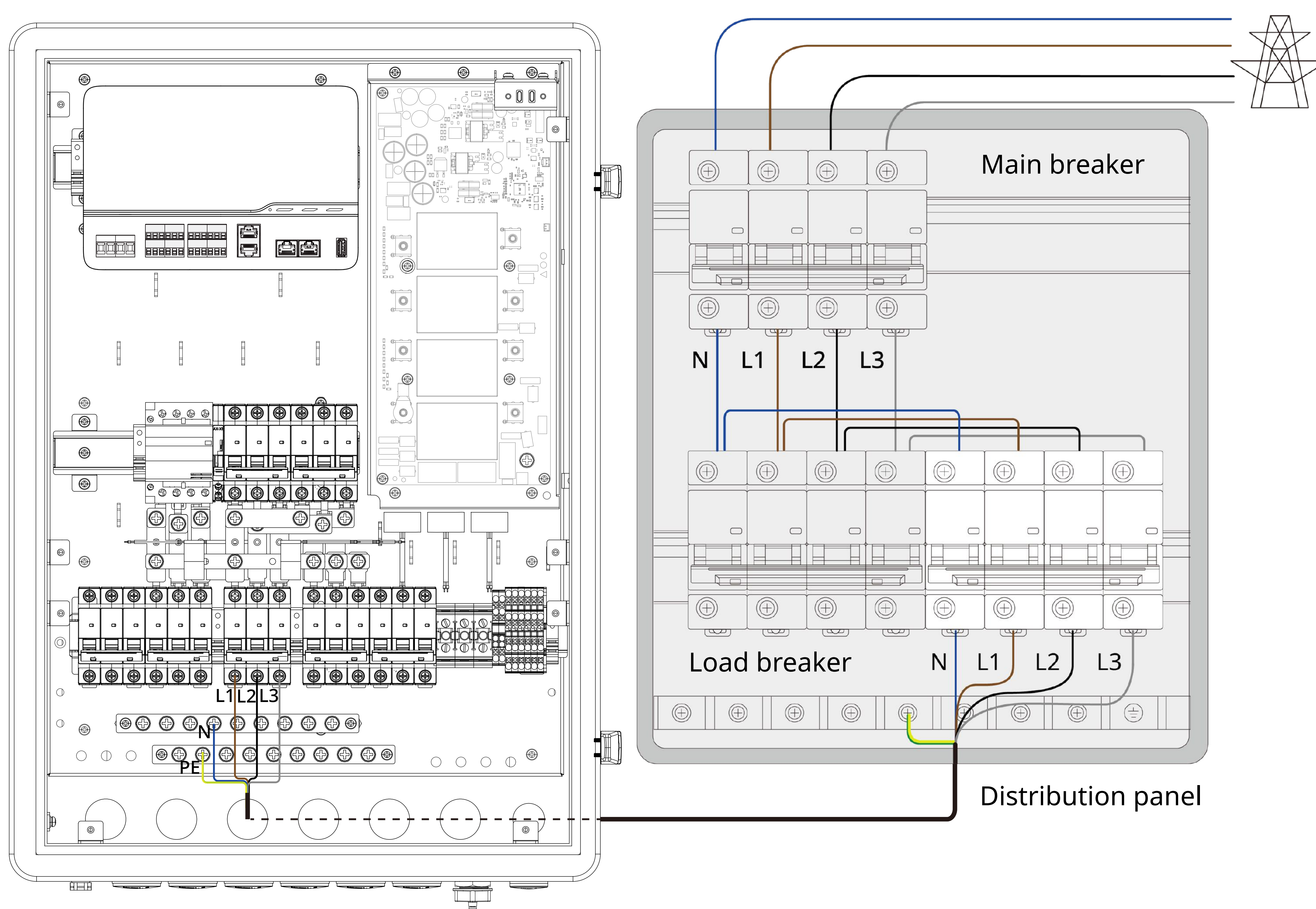

-L1 -L2 -L3 -N -PE

NOTE:

- The recommended rated residual current for compatible RCDs is greater than 100mA, with 30mA being the minimum acceptable threshold. A residual current device RCD type A can be used. Additionally, the maximum current-carrying capacity of the RCD should match the parameters of the grid-side breaker within the CombinerPro.

6.5.4 Wire from the Grid

- Bring in the cables from the grid through the grid hole of the cabinet.
- Connect the L cable to the grid breaker, and connect the ground cable to the PE terminal block as shown. Connect the N cable to the N terminal block.
- Tighten the screws by using a Phillips #2 screwdriver with a torque of 3.5–4 N·m.

NOTE:

- The consumption CTs are already built-in.

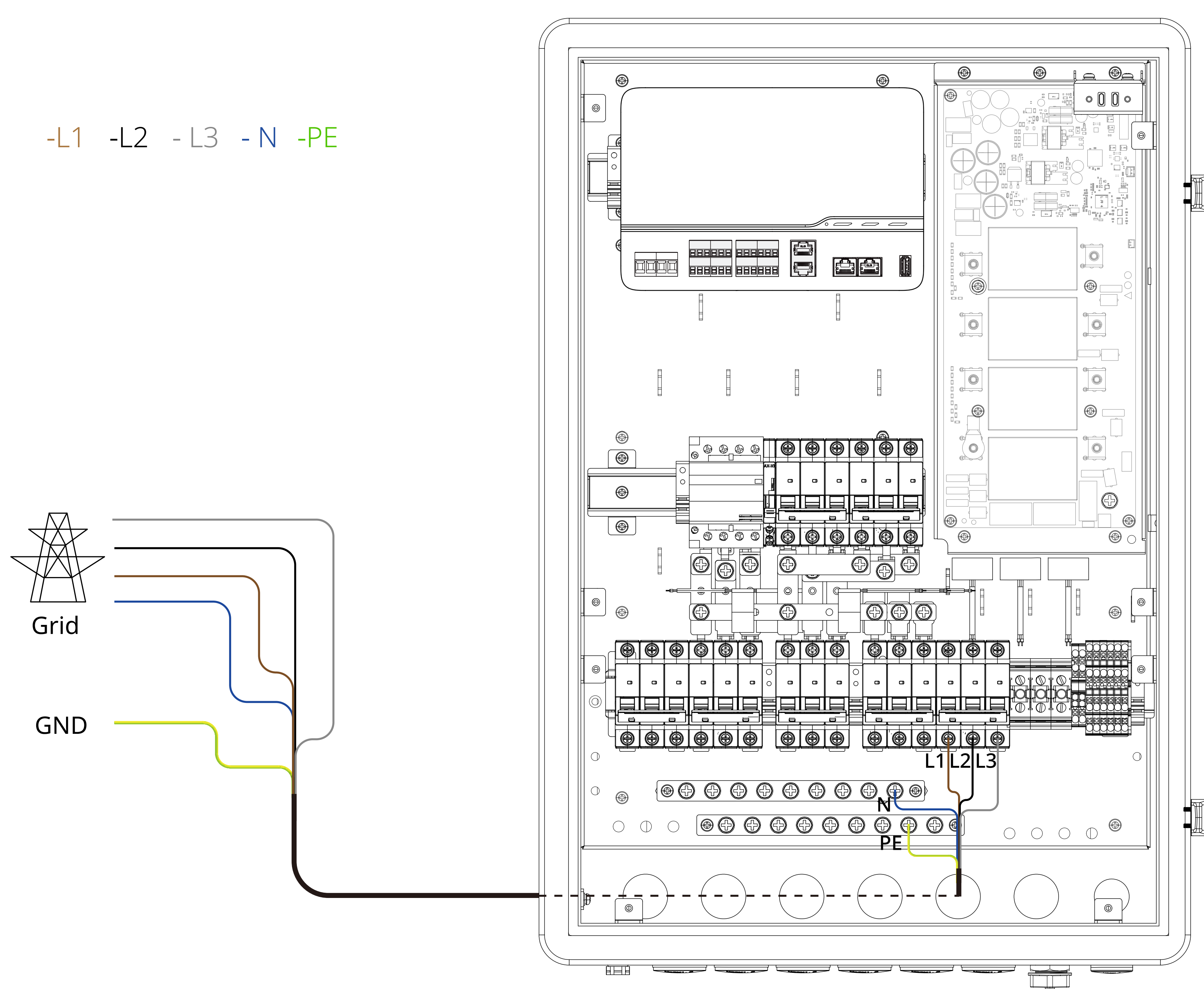

NOTE:

- The recommended rated residual current for compatible RCDs is greater than 100mA, with 30mA being the minimum acceptable threshold. A residual current device RCD type A can be used. Additionally, the maximum current-carrying capacity of the RCD should match the parameters of the grid-side breaker within the CombinerPro.

6.5.5 (Optional) Wire from the battery

- Bring in the cables from the battery through the battery hole of the cabinet.
- Connect the cables (L1, L2, L3) to the battery breaker and connect the ground cable to the PE terminal block as shown. Connect the N cable to the N terminal block.
- Tighten the screws by using a Phillips #2 screwdriver with a torque of 2–2.5 N·m.
- Connect the CAN COM cable of the battery to the terminal as shown in the right figure.

NOTE:

- The Communication interface information could be found in 3.7.

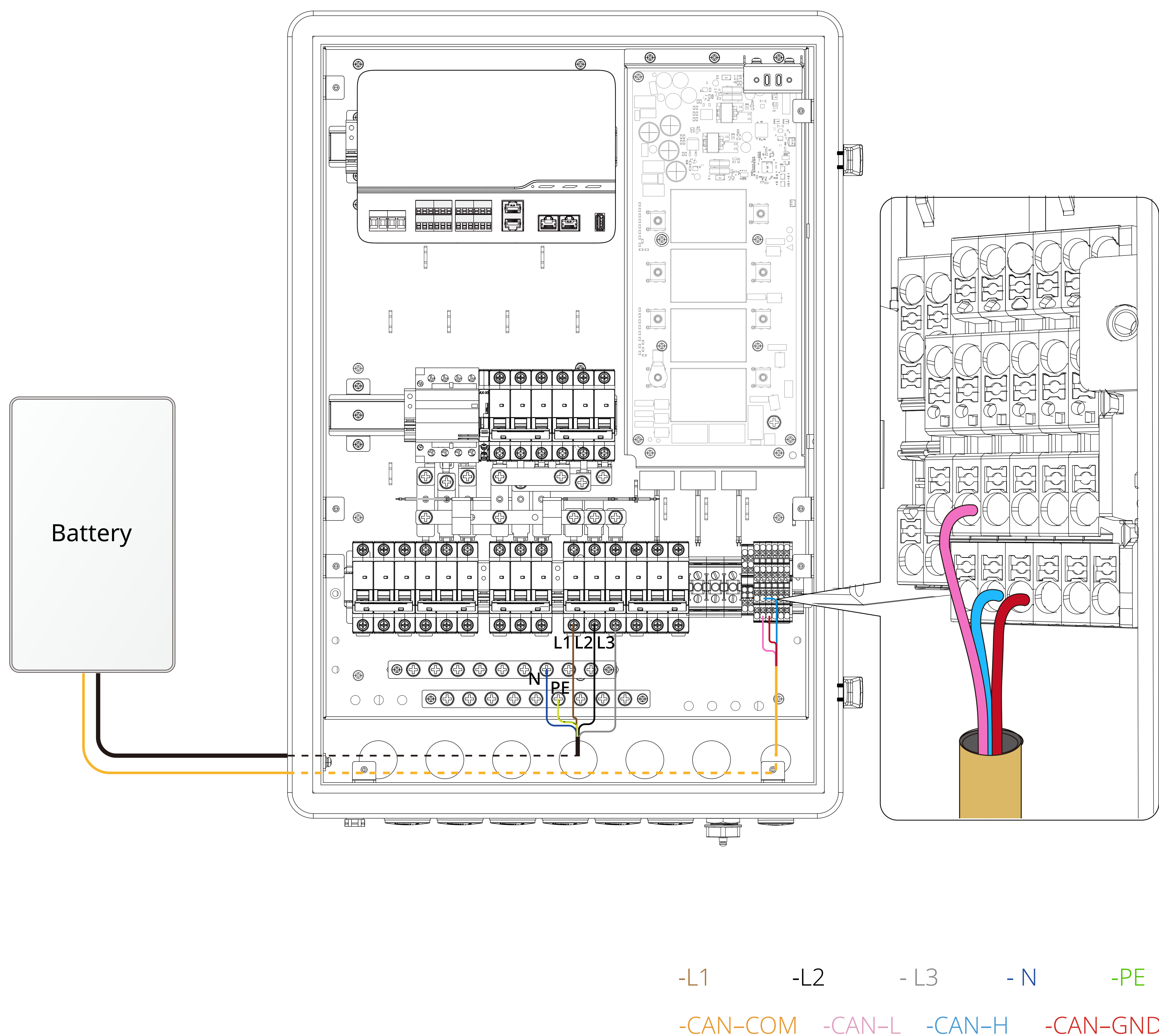

6.5.6 (Optional) Wire from the router

- When you use ETH to connect to Atmoce-Cloud, bring in the cable from the home broadband router through the COM hole of the cabinet.
- Connect the 802.3 Cat 6 UTP ethernet cable to the RJ45 terminal in the cabinet as shown in the figure.

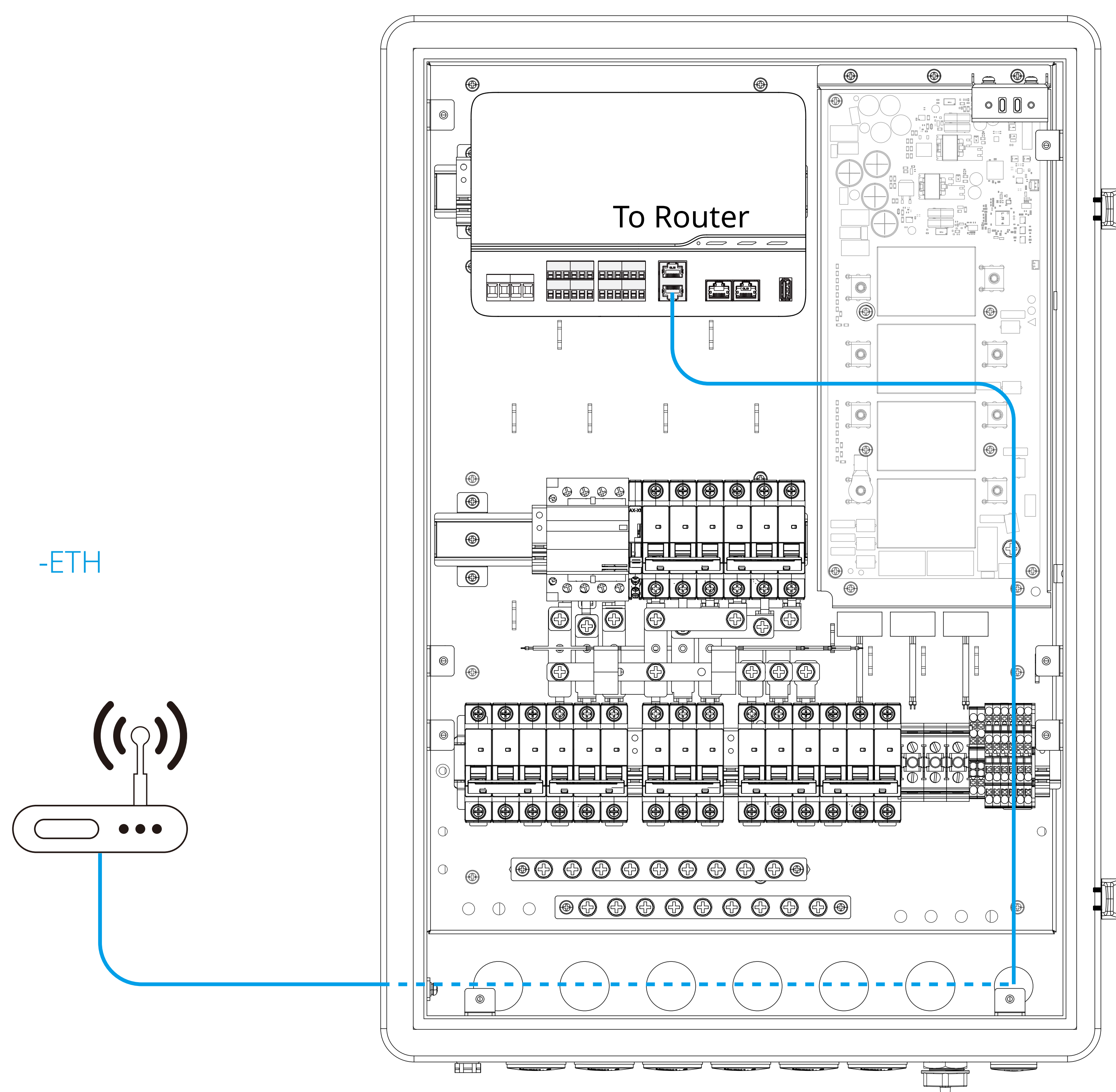

6.5.7 (Optional) Communication interface

- a. The MC100PRO-T3P supports ETH, RS485 and DO CTRL interfaces, etc. Connect the cables from the devices to the communication terminal block as the wire diagram in the cabinet. Bring in the cable from COM hole is recommended.

NOTE:

- M-Gateway supports more flexible and smart control by integrated communication interfaces. Refer to "M-Gateway User Manual" for more information.

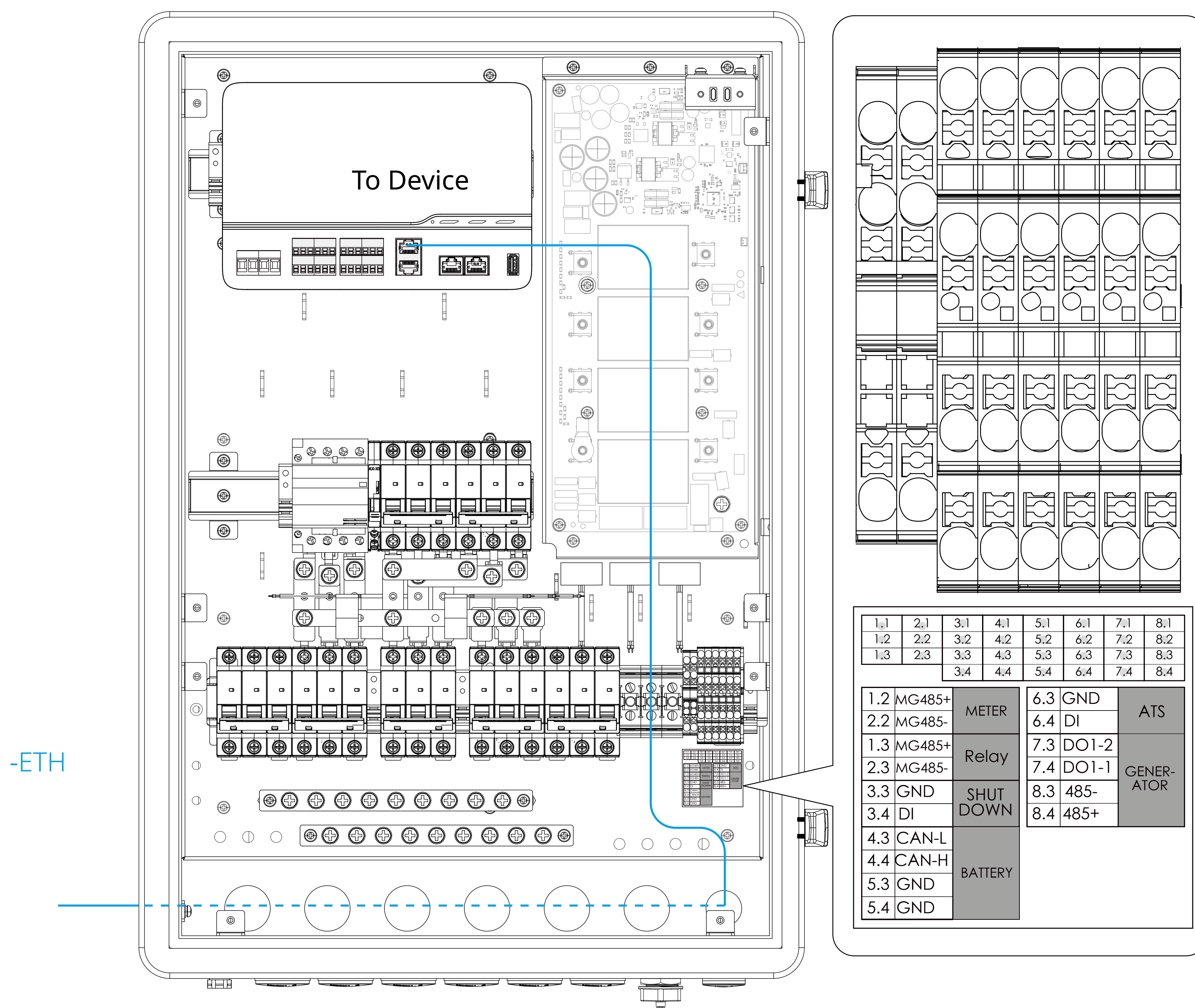

6.5.8 (Optional) Wire from Non Backup Load

- Bring in the cable from the Non Backup Load through the Load hole of the cabinet.
- Connect the cables (L1, L2, L3) to the Non Backup breaker.
- Connect the ground cable to the PE terminal block as shown. Connect the N cable to the N terminal block.

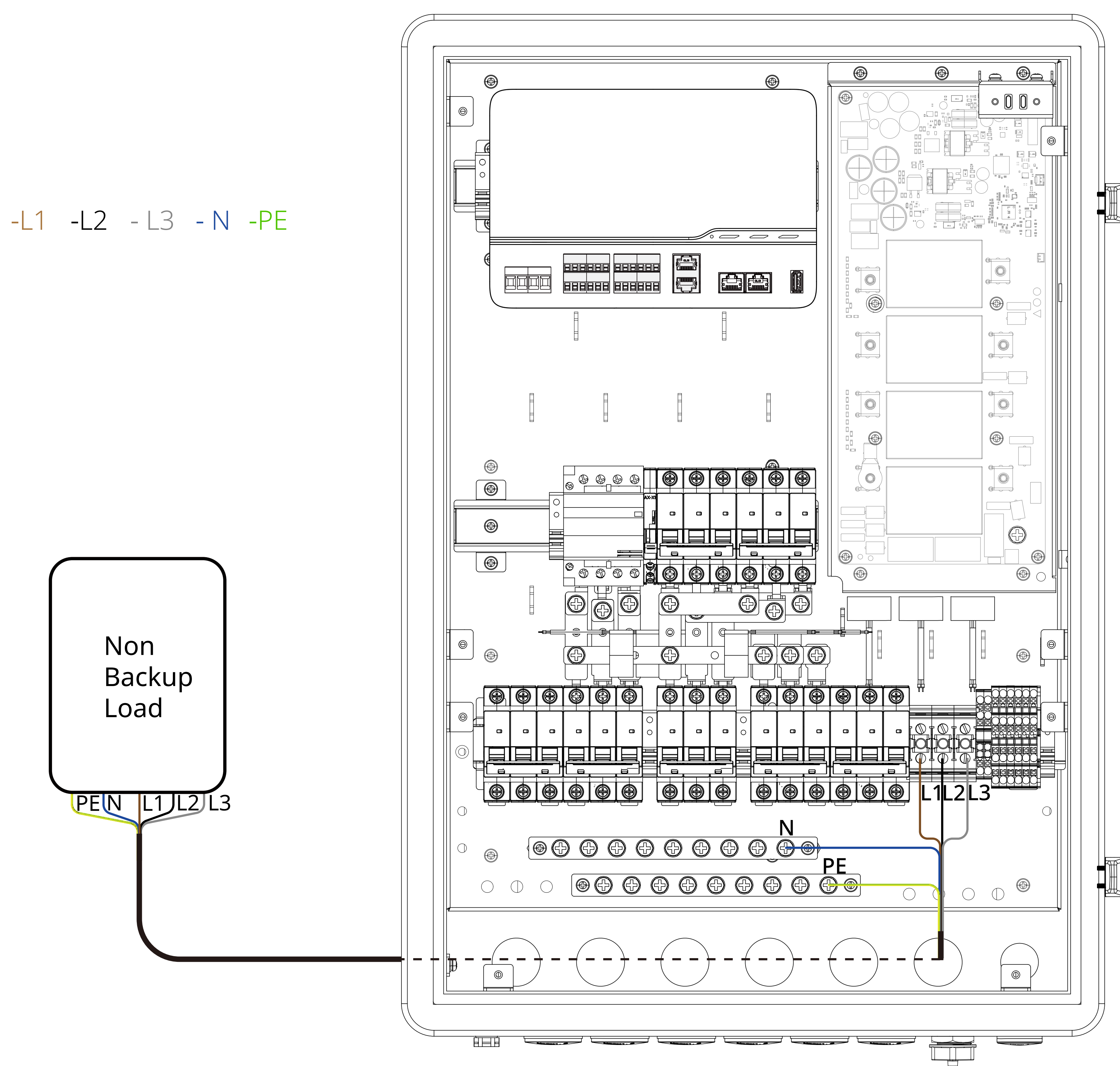

6.5.9 Wifi Dongle connection

- a. Unscrew the cap at the Wifi port on the bottom of the case. Plug in the Wifi Dongle into the Wifi hole.

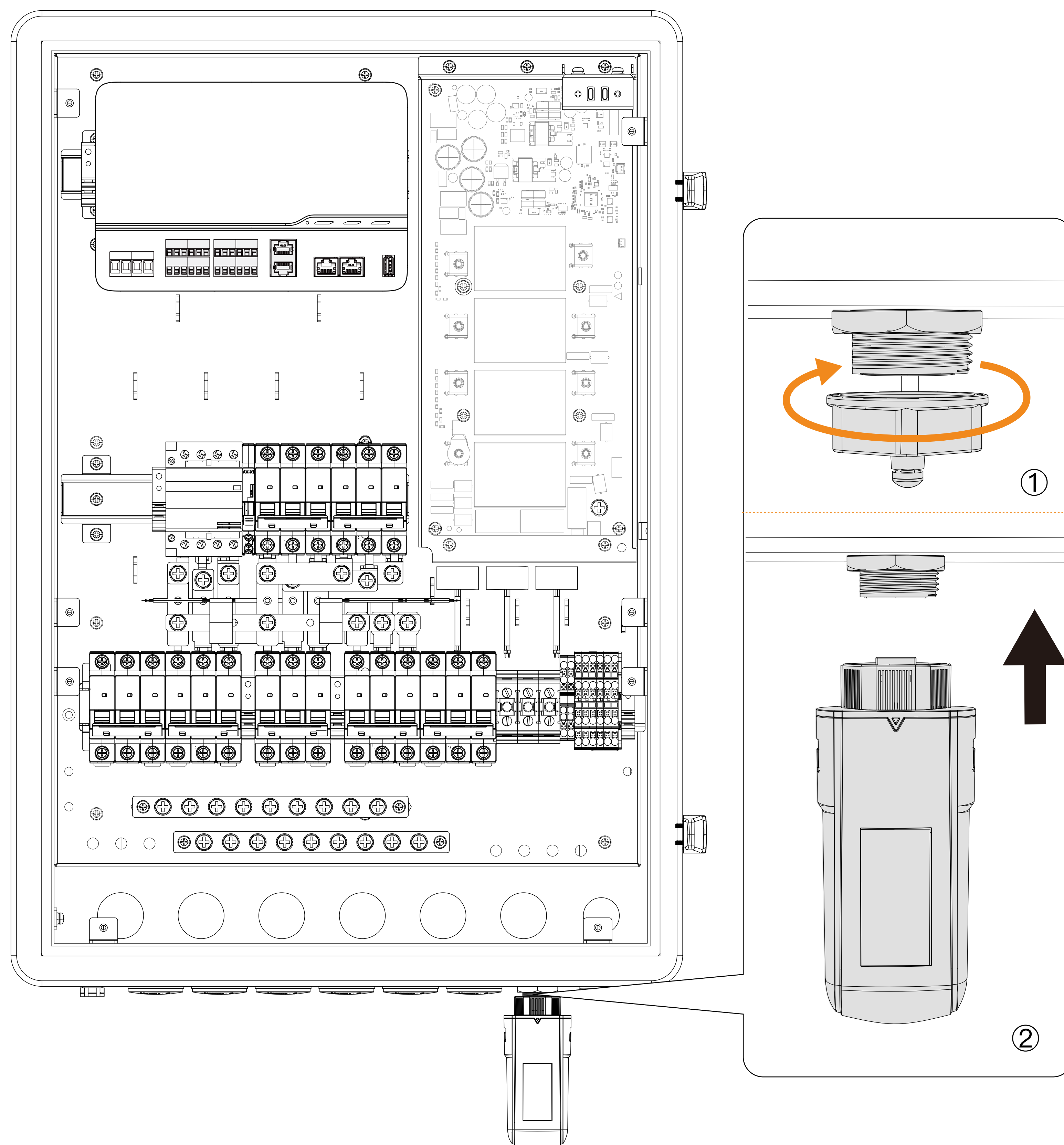

6.6 Power on the system

- a. Turn on the main breaker and M-CombinerPro breaker in the distribution panel.
- b. To check the phase sequence, perform the following steps:
 - Use the multimeter to measure the voltage between the N pole and L1 pole of grid breaker as shown in the figure.
 - Measure the voltage between the N pole and L2 pole.
 - Measure the voltage between the N pole and L3 pole.
- c. If the voltage value is approximately the nominal phase voltage, e.g. 220 V, 230 V and 240 V, re-install the protective panel.
- d. Turn on the grid and other breakers in the combinerPro, and the LEDs on the MR100 and MG100 will be on.

NOTE:

- If the voltage value is outside the range (184 to 276 V), do not switch on the grid breaker inside the combinerPro. Check the cable connection to avoid damaging the device and voiding the warranty.

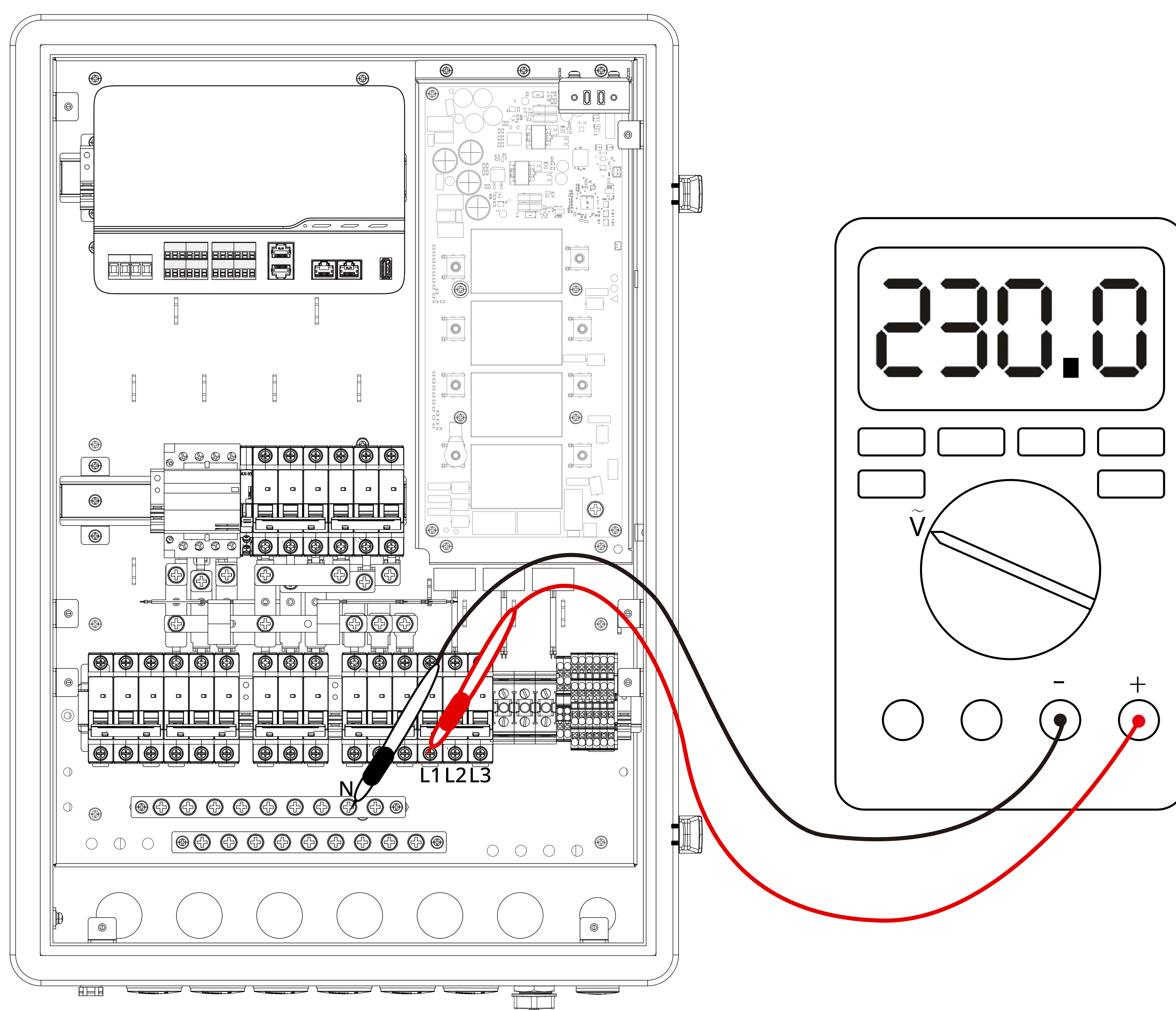

6.7 Activate the system

- a. Log in to the ATMOZEN APP on your mobile phone and follow the deployment guide in the app to activate the system.
- b. After the system is activated, all LEDs will be solid green.

6.8 Close the M-CombinerPro

- a. Close the door of the MC100PRO-T3P.

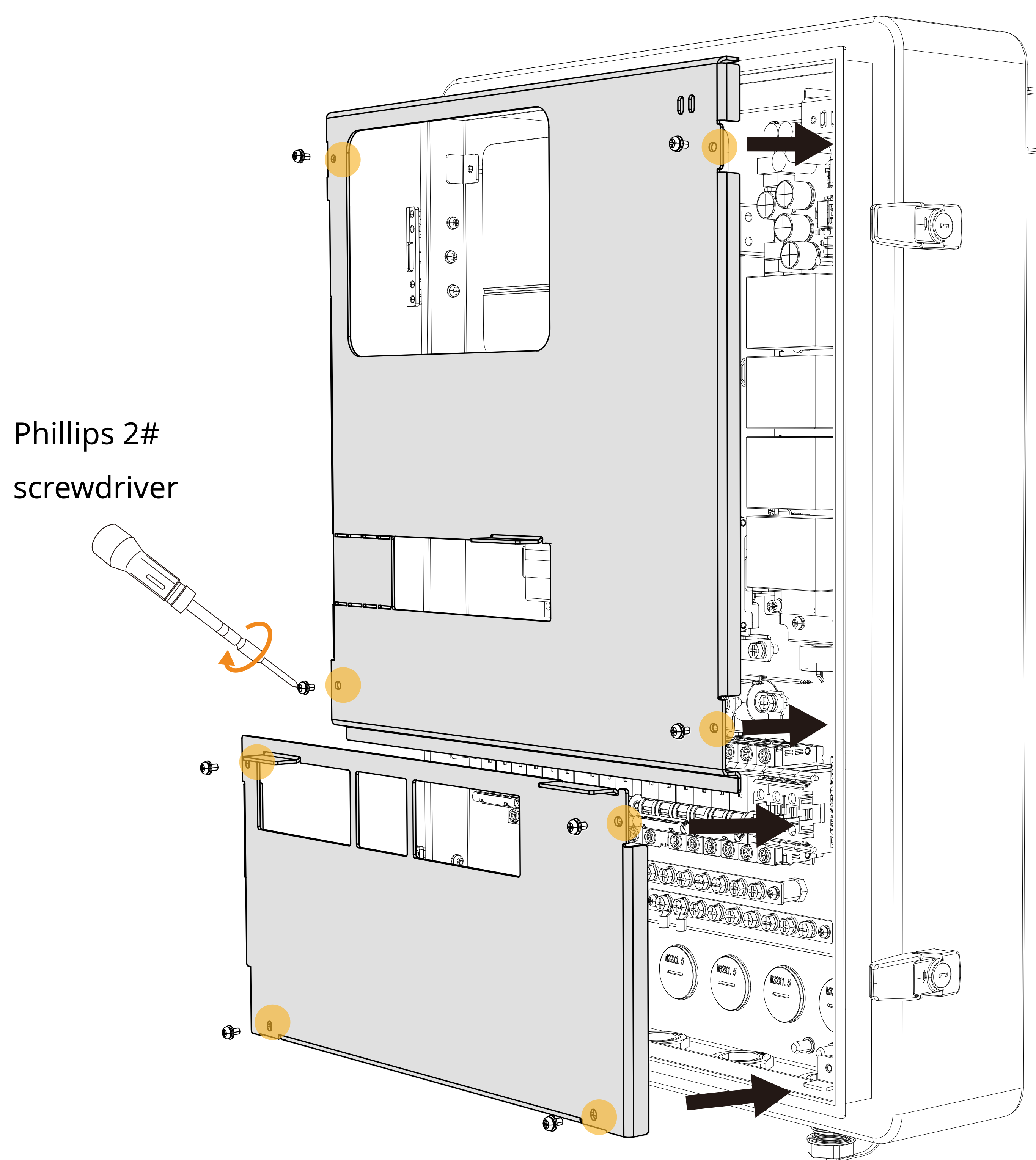

6.9 LED indicator description

a. The above two LEDs reveal the status and mode of the backup part. The left LED represents Status and the right one represents Mode.

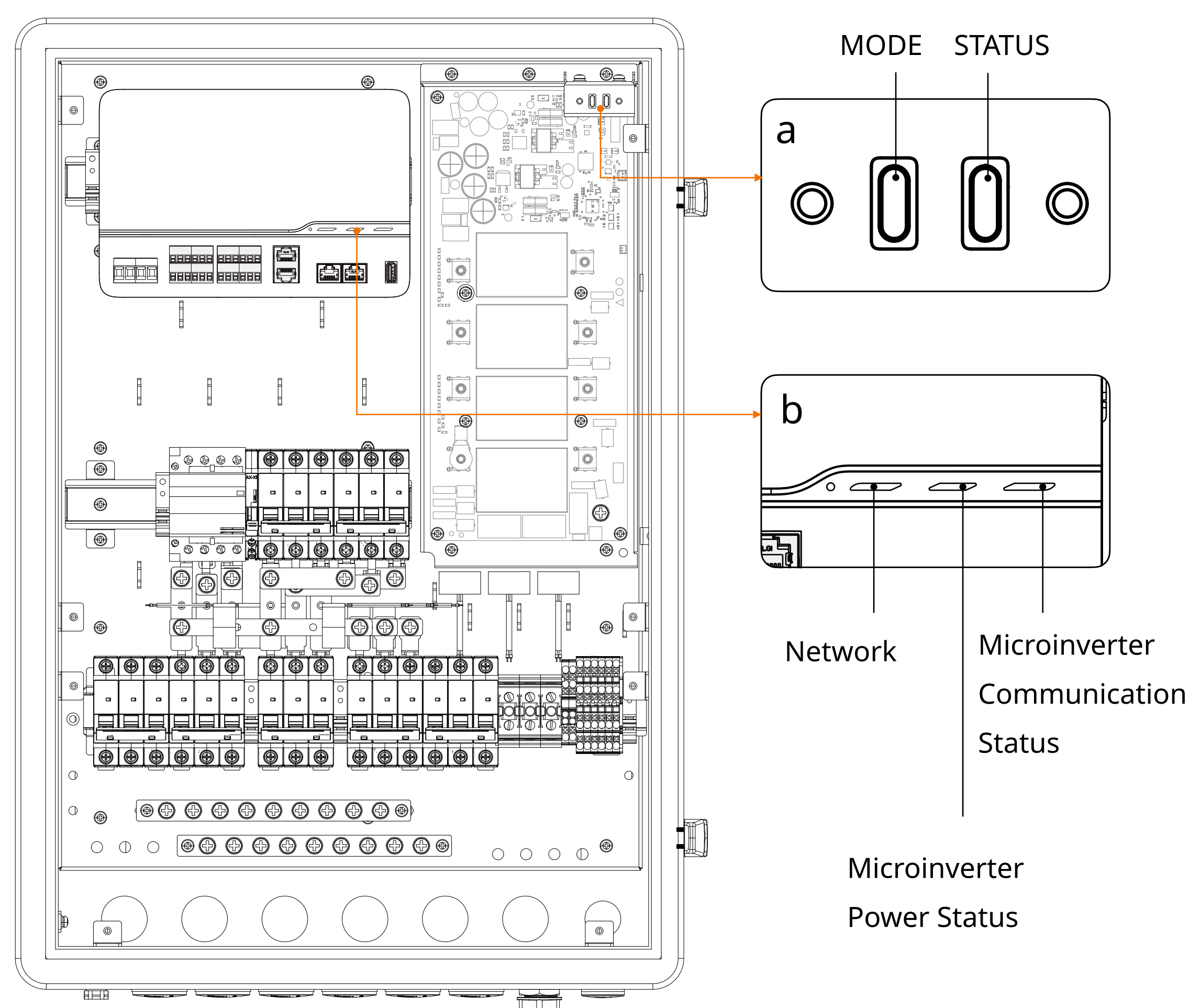

Function	Colour		Description
Status	Solid Green		Normal
	Quick Flash Orange		Upgrading mode
	Slow Flash Red		Communication fault
	Solid Red		System fault
Mode	Solid Green		On-grid mode
	Solid Orange		Off-grid mode
	Slow Flash Green		Generator mode

b. The three LEDs on the Gateway reveal 'Microinverter Communication Status' 'Microinverter Power Status' 'Network' from left to right.

Function	Colour		Description
Network Status	Solid Green		Connecting to cloud.
	Quick Flash Green		Connecting to app via Bluetooth.
	Slow Flash Red		No network available.
Microinverter Power Status	Solid Green		All communicating microinverters are generating power.
	Slow Flash Orange		At least one microinverter is not generating power.
	Dimmed		All microinverters are not generating power.
Microinverter Communication Status	Solid Green		All microinverters are communicating normally.
	Quick Flash Green		The MG100 is detecting microinverters.
	Slow Flash Orange		At least one microinverter is not in communicating.
	Slow Flash Red		All microinverters are not communicating (not due to low light or night time).
	Dimmed		All microinverters are not communicating (due to low light or night time).
ALL	Slow Flash Green		Software update is in progress.

DRED Device support

7.1 DRM Interface

a. 1 RJ45 interface in Gateway is used for controlling DRED devices as shown in the diagram.

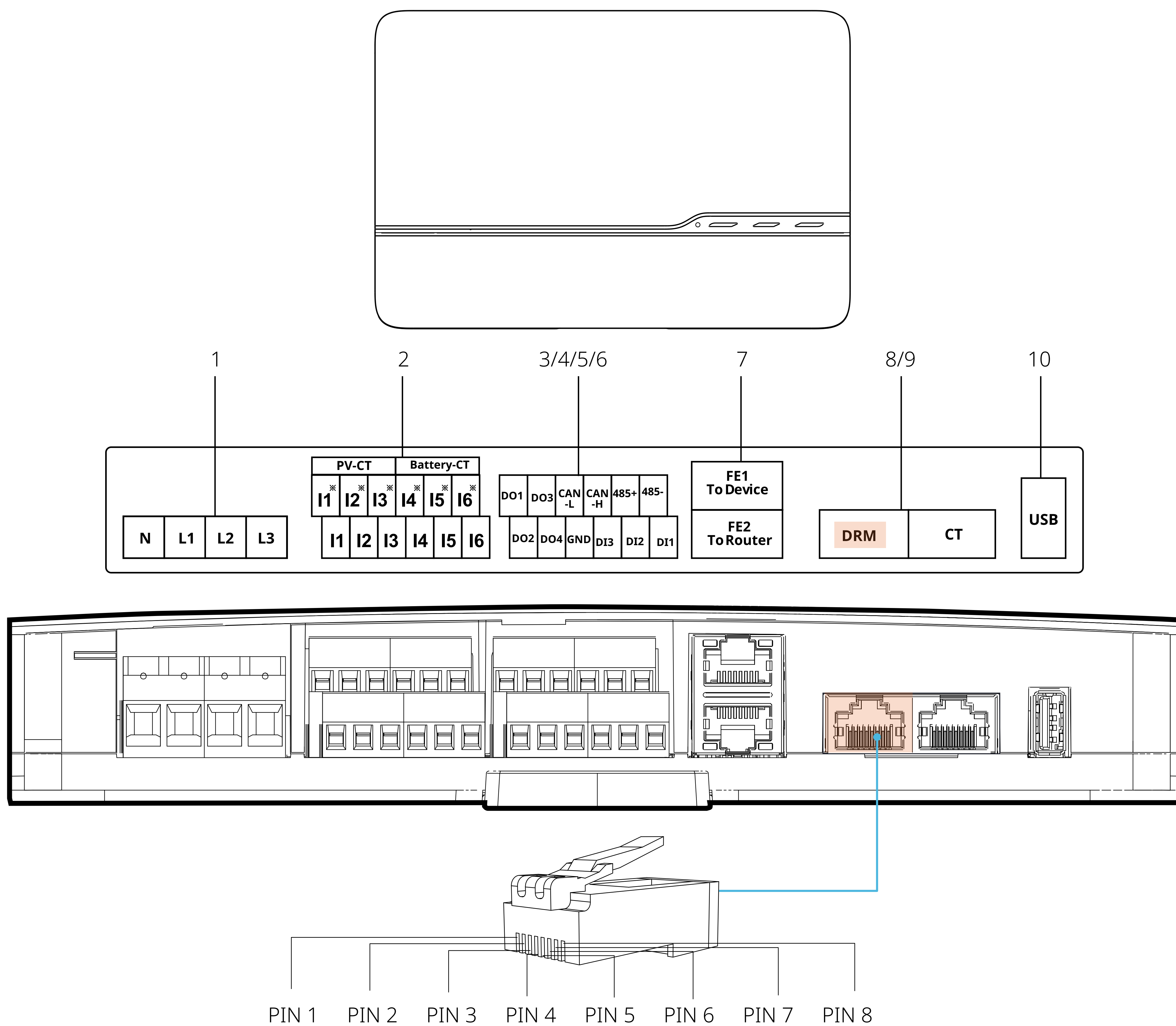

PIN	Definition
1	DRM1/5
2	DRM2/6
3	DRM3/7
4	DRM4/8
5	REF GEN/0
6	COM LOAD/0 (DRM0)
7	/
8	/

NOTE:

- The system currently only supports DRM0; other pins are for informational purposes only.

7.2 Combined with CombinerPro

- a. Please see the diagrams below. 1 RJ45 cable will be connected to the Gateway in the CombinerPro through the COM hole of the cabinet.

CombinerPRO-S1P

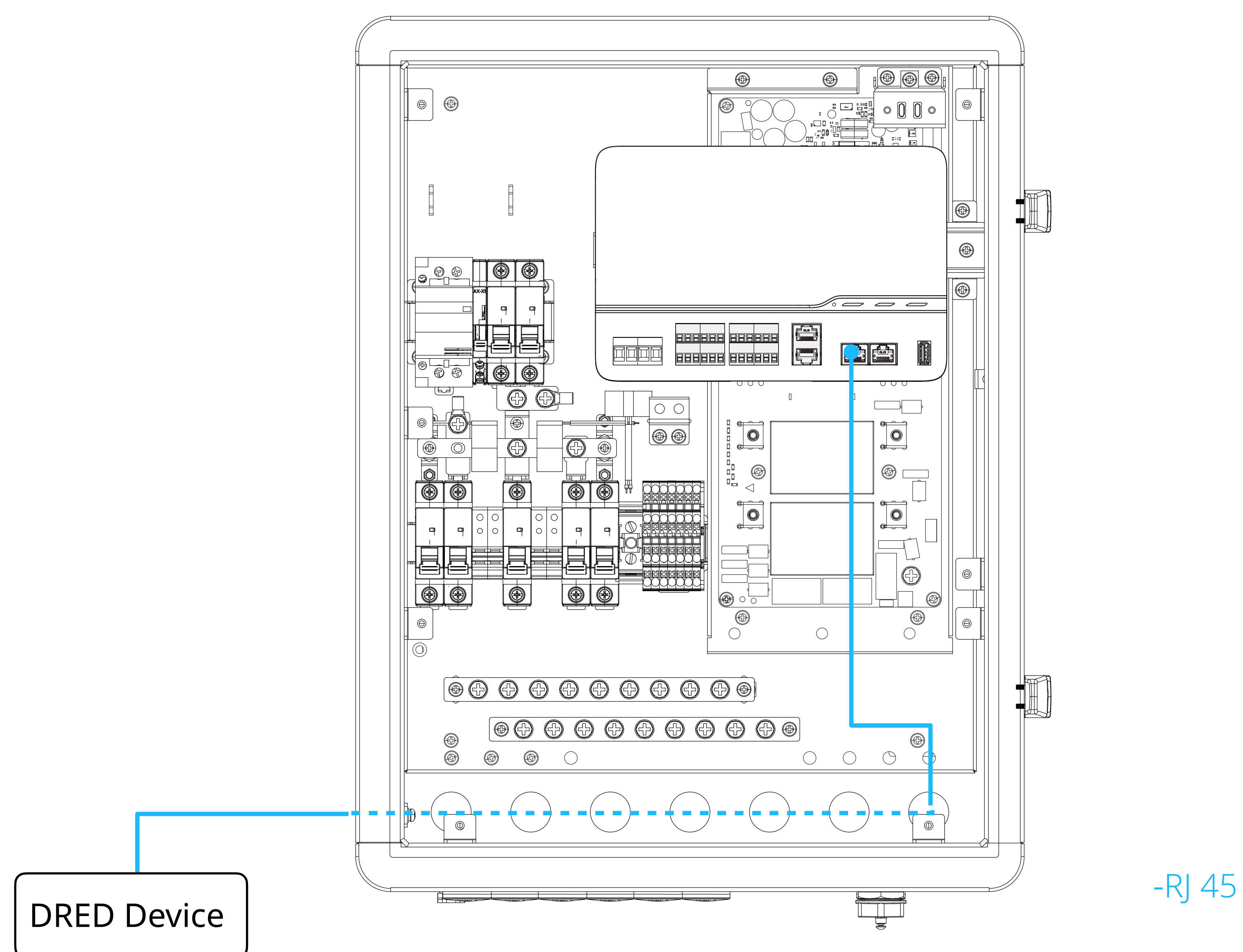

CombinerPRO-T3P

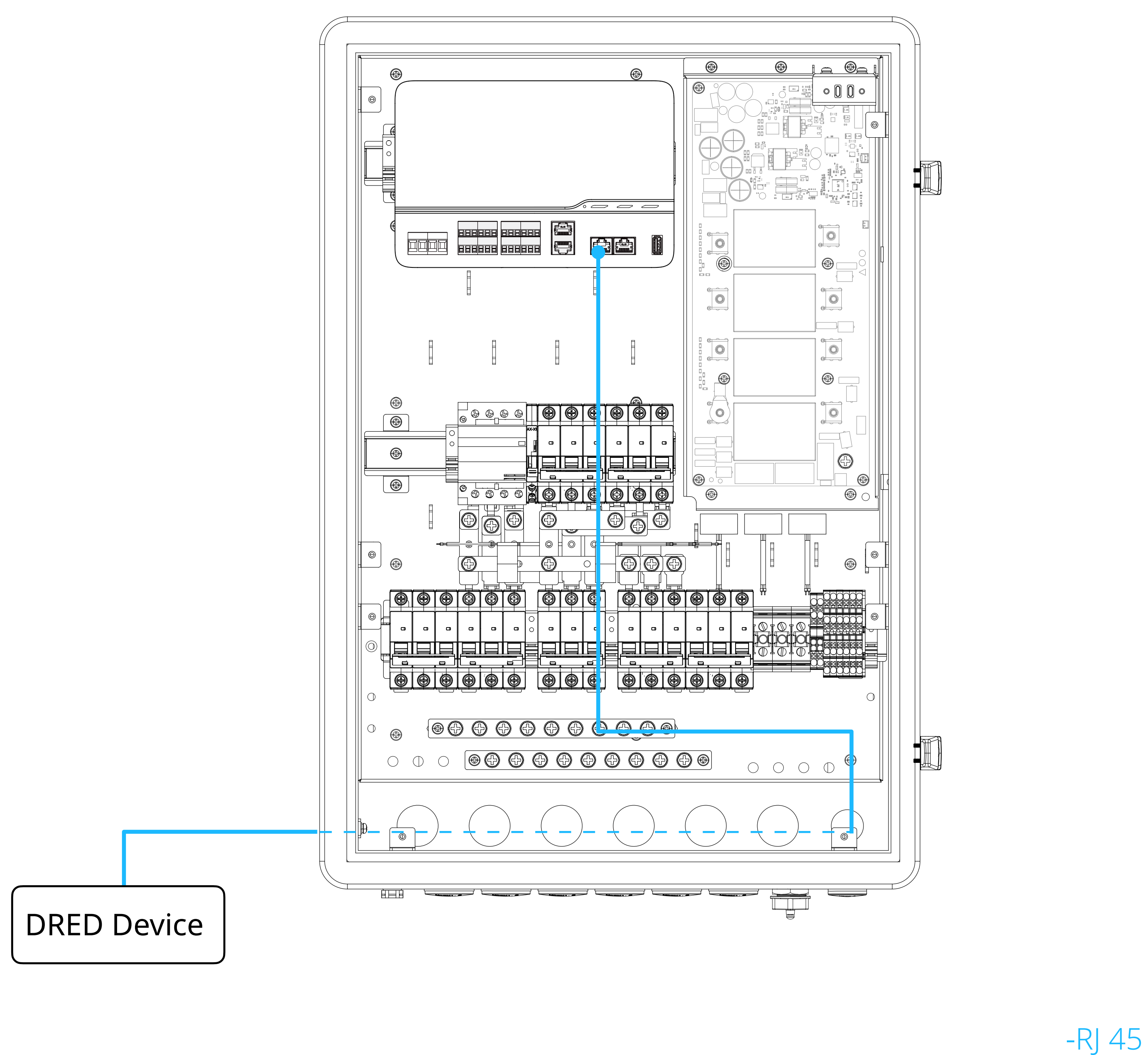

7.3 Combined with Gateway

Please see the diagrams below. The steps are as below:

- a. Connect the CAN cable to the communication terminal of the Gateway as the label.
- b. 1 RJ45 cable will be connected to the Gateway DRM interface.

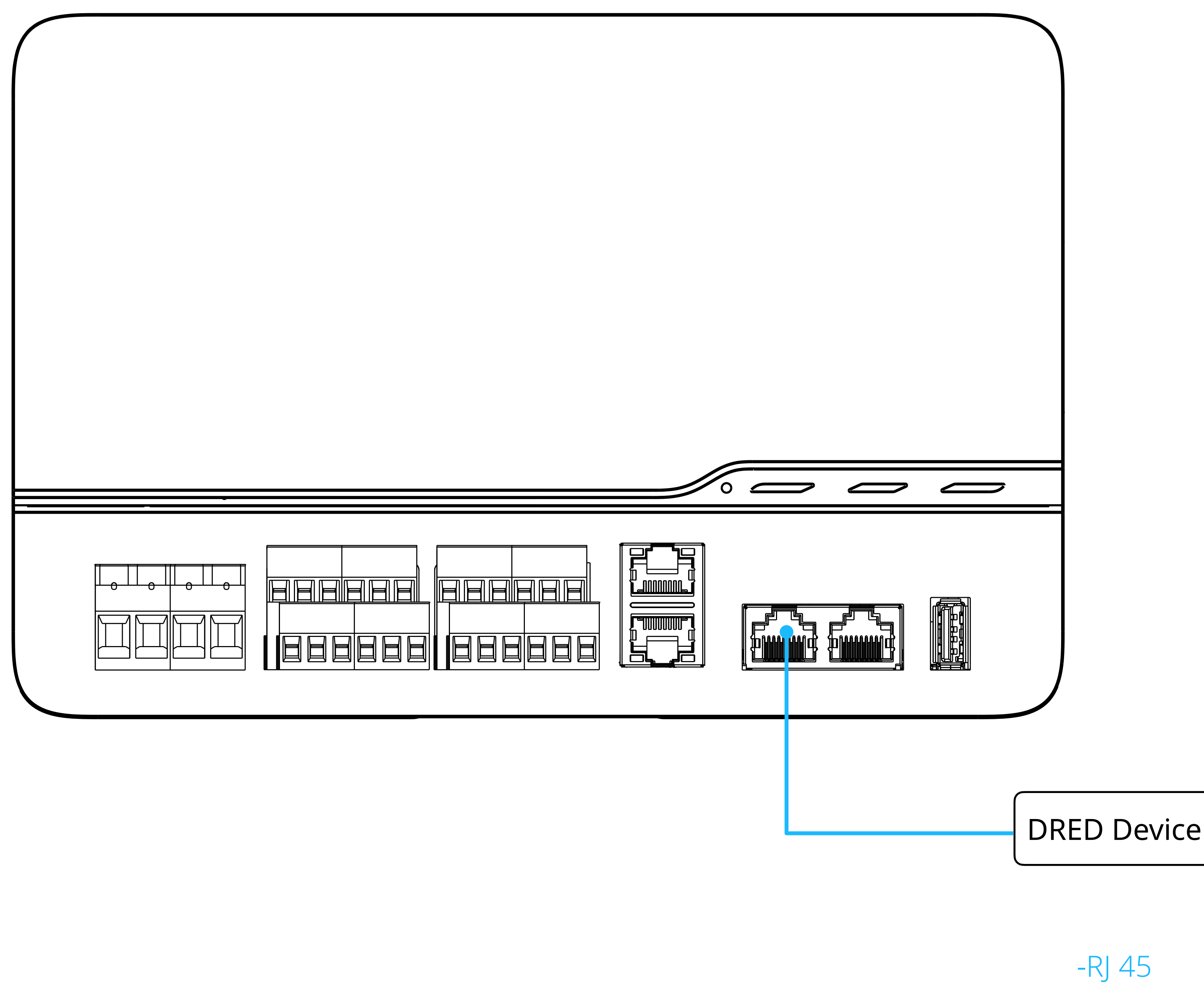

Operation and Maintenance

8.1 M-ELV Battery Working Mode

The battery operating mode supports Self-consumption and Time of Use. The settings are shown in the figure.

- Tap Site Settings of the site.
- Select Battery Working Mode to setting.

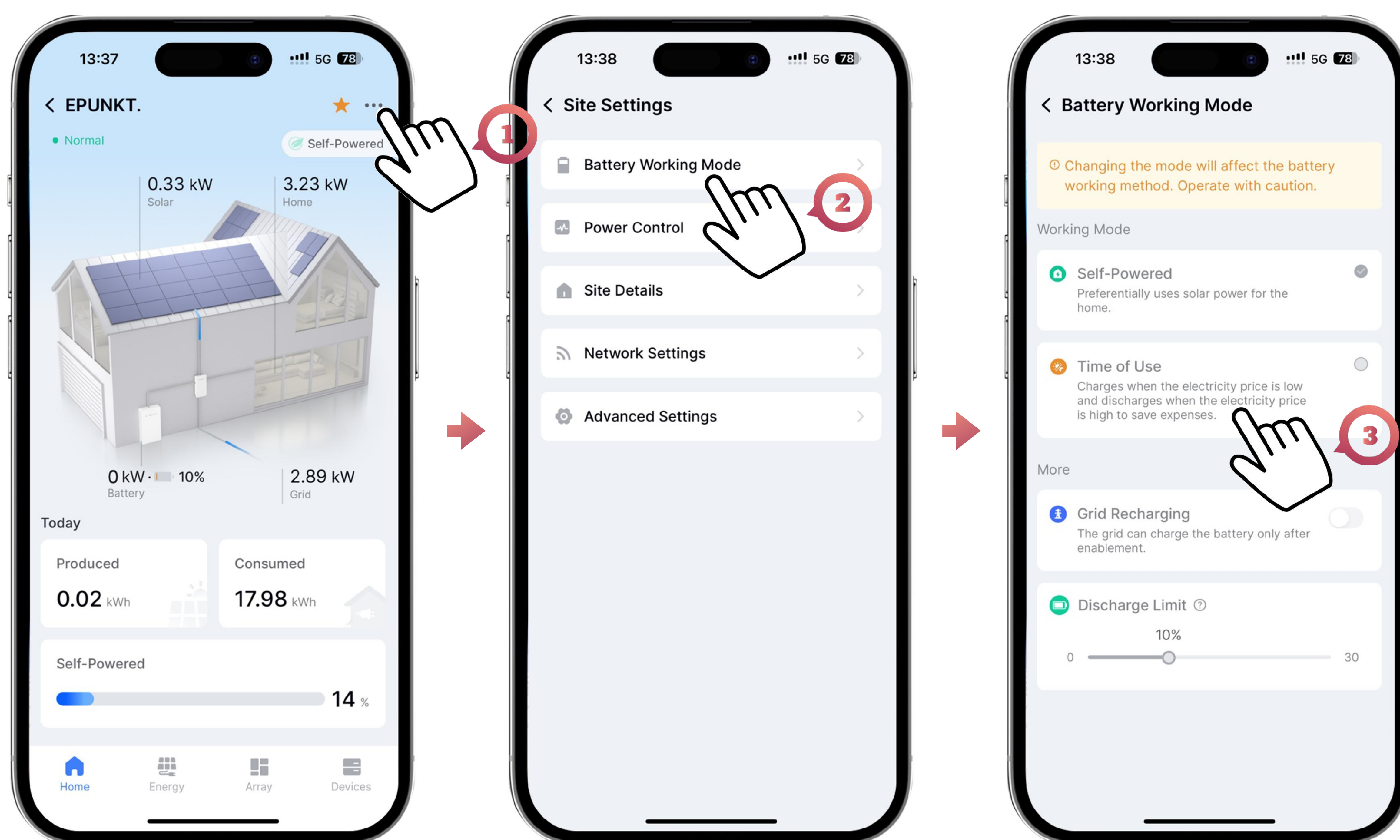

Self-consumption mode

Description:

Prioritise the consumption of green energy from household photovoltaic power generation to reduce dependence on the grid. M-ELV batteries only store excess photovoltaic power and discharge power for household use when photovoltaic power generation is insufficient. Suitable for regions with high electricity prices, low or no FIT subsidies for grid connection.

Function:

- a. When solar power generation is sufficient: Household loads directly use solar power, with excess stored in the battery. If there is still surplus, it is fed into the grid.
- b. When solar power generation is insufficient (e.g., at night): Battery discharge is prioritised. If load power is high, the insufficient portion is supplied by the grid.

TOU (Time of use) mode

Description:

Based on the grid's time-of-use electricity rates (with different rates for peak, off-peak, and low-peak periods), the system automatically adjusts the charging and discharging strategy to utilise price differentials and reduce electricity costs. The electricity rate periods must be pre-set. This is suitable for scenarios with significant differences between peak and off-peak electricity rates.

Function:

- a. Charging period: Prioritise charging the M-ELV battery from the grid and excess solar power generation, with the M-ELV battery not discharging.
- b. Discharging period: Excess solar power generation can be used to charge the M-ELV battery, which can supply power to the load.
- c. Other period: Excess solar power generation can be used to charge the M-ELV battery, which does not discharge.

NOTE:

- In some countries, grid charging of energy storage systems is not permitted, and this mode is prohibited.
- This mode requires at least one set of charging time periods or discharging time periods. (In off-grid mode, when the grid power fails, the energy storage system can discharge at any time.)

8.2 Parameter Setting

8.2.1 Operations Related to the installer User and home owner

- If you are Installer, you can set grid parameters, make protection settings and power adjustments.
- If you are a home owner, you can read the grid parameters, protection settings and power adjustments data. But you could not adjust the data.

8.2.2 Setting Grid Parameters

- Tap Parameters - Configure Parameters - Grid Parameters - Grid Profile Settings to access the parameters setting screen.

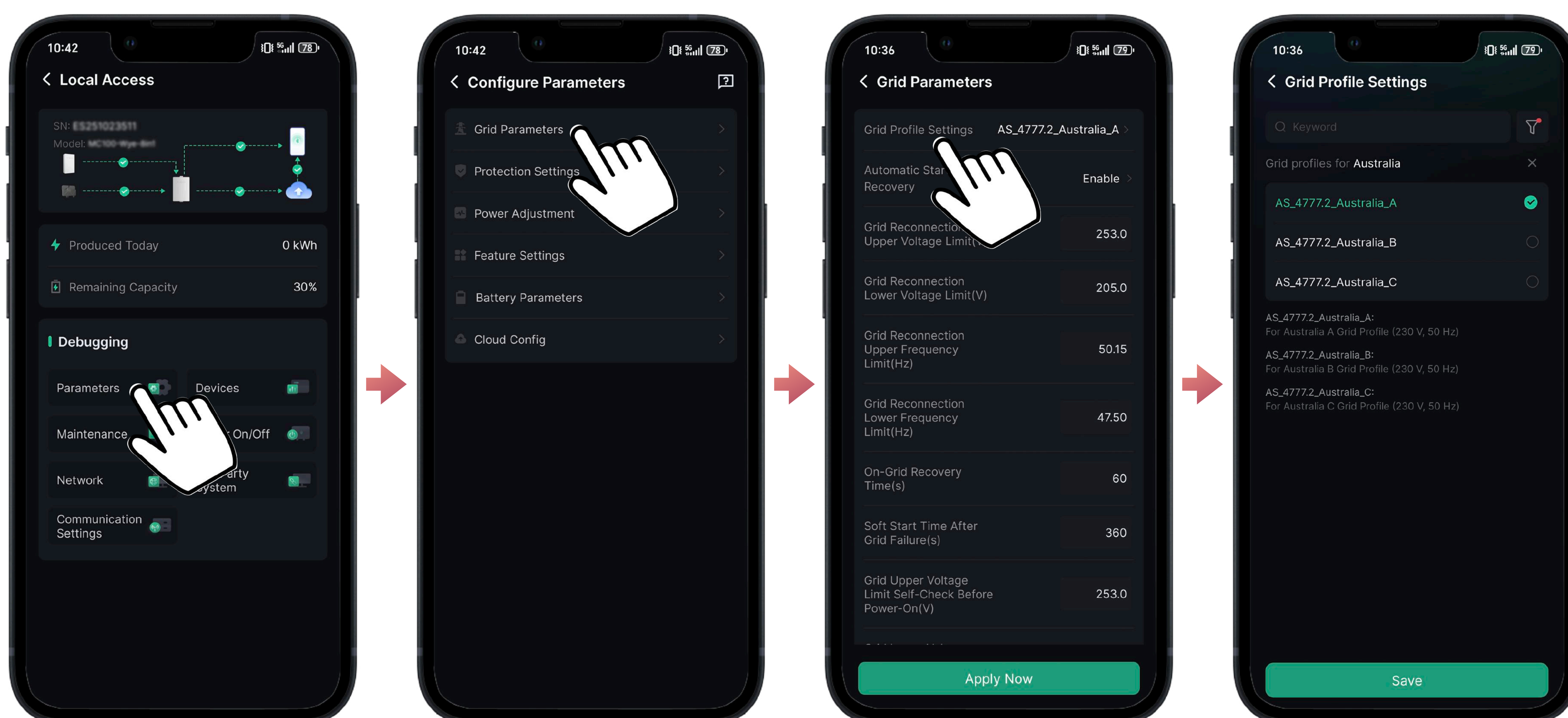

Parameter Name	Unit	Value Range
Grid Profile Settings		AS_4777.2_Australia_A/ AS_4777.2_Australia_B/ AS_4777.2_Australia_C/
Automatic Startup upon Grid Recovery		Disable/Enable
Grid Reconnection Upper Voltage Limit	V	230.0 to 322.0
Grid Reconnection Lower Voltage Limit	V	103.5 to 230.0
Grid Reconnection Upper Frequency Limit	Hz	50.00 to 60.00
Grid Reconnection Lower Frequency Limit	Hz	40.00 to 50.00
On-Grid Recovery Time	s	0 to 7200
Soft Start Time After Grid Failure	s	0 to 7200
Grid Upper Voltage Limit Self-Check Before Power-On	V	230.0 to 322.0
Grid Lower Voltage Limit Self-Check Before Power-On	V	103.5 to 230.0
Grid Upper Frequency Limit Self-Check Before Power-On	Hz	50.00 to 60.00
Grid Lower Frequency Limit Self-Check Before Power-On	Hz	40.00 to 50.00
Installation Date Self-Check Before Power-On	s	0 to 7200
Soft Start Time Self-Check Before Power-On	s	0 to 7200

8.2.3 Setting Protect Parameters

- a. Tap Parameters - Configure Parameters - Protection Settings to access the parameters setting screen.

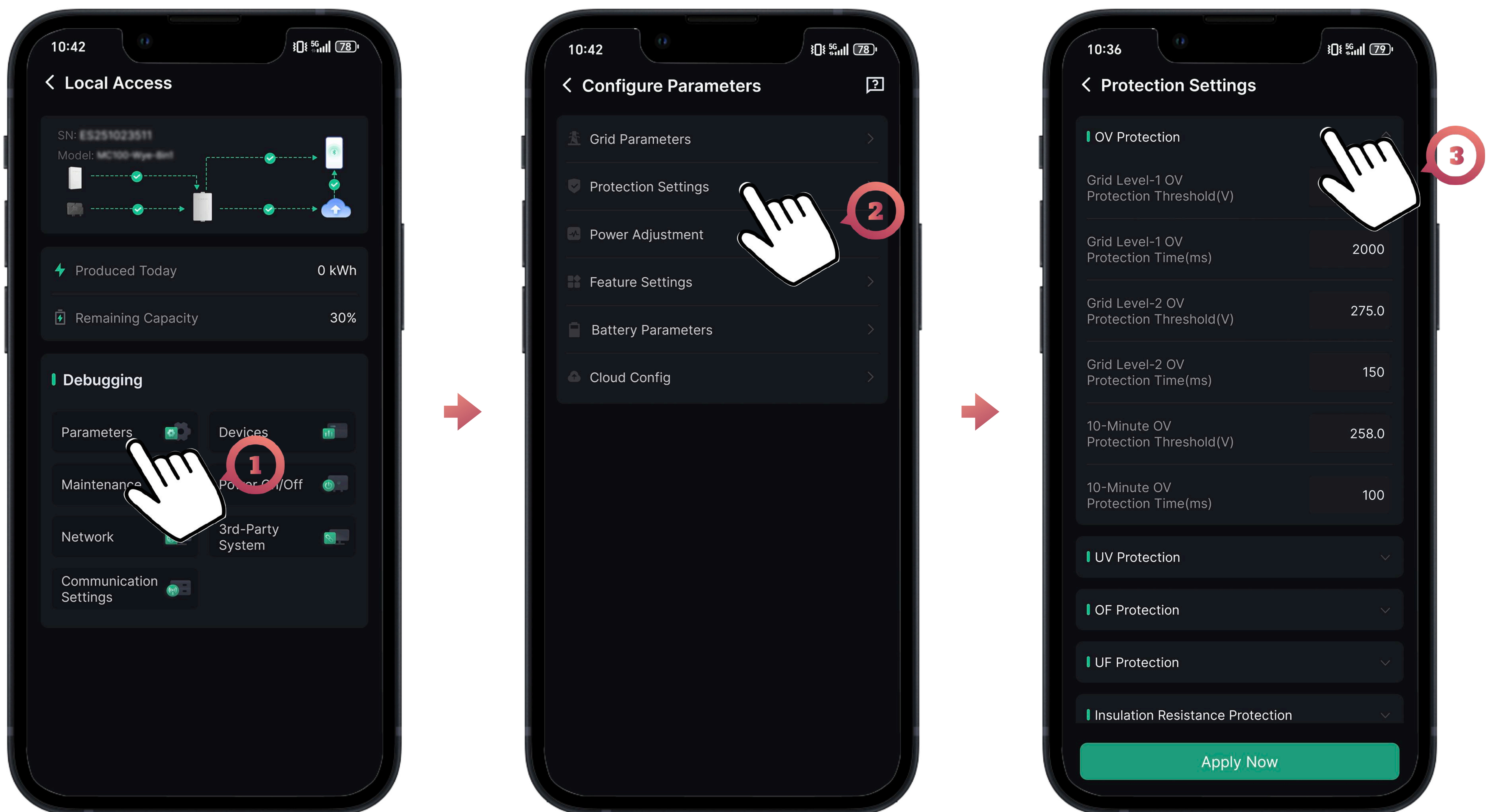

Protect Parameters List

Parameter Name	Unit	Value Range
OV Protection		
Value Range		230.0 to 322.0
Grid Level-1 OV Protection Time	ms	50 to 7200000
Grid Level-2 OV Protection Threshold	V	230.0 to 322.0
Grid Level-2 OV Protection Time	ms	50 to 7200000
10-Minute OV Protection Threshold	V	230.0 to 322.0
10-Minute OV Protection Time	ms	50 to 7200000
UV Protection		
Grid Level-1 UV Protection Threshold	V	34.5 to 230.0
Grid Level-1 UV Protection Time	ms	50 to 7200000
Grid Level-2 UV Protection Threshold	V	34.5 to 230.0
Grid Level-2 UV Protection Time	ms	50 to 7200000
OF Protection		
Grid Level-1 OF Protection Threshold	Hz	50.00 to 60.00
Grid Level-1 OF Protection Time	ms	50 to 7200000
Grid Level-2 OF Protection Threshold	Hz	50.00 to 60.00
Grid Level-2 OF Protection Time	ms	50 to 7200000
UF Protection		
Grid Level-1 UF Protection Threshold	Hz	40.00 to 50.00
Grid Level-1 UF Protection Time	ms	50 to 7200000
Grid Level-2 UF Protection Threshold	Hz	40.00 to 50.00
Grid Level-2 UF Protection Time	ms	50 to 7200000
Insulation Resistance Protection		
Insulation Resistance Detection		Disable/Enable
Island Protection		
Active Island Protection		Disable/Enable
ROCOF Protection		
ROCOF Protection		Disable/Enable
ROCOF Protection Threshold	Hz/s	0.0 to 100.0
ROCOF Protection Duration	ms	50 to 7200000

8.2.4 Power Control

A. Power Adjustments (Generation Limit Control)

a. Tap Parameters - Power Adjustment to access the parameters setting screen.

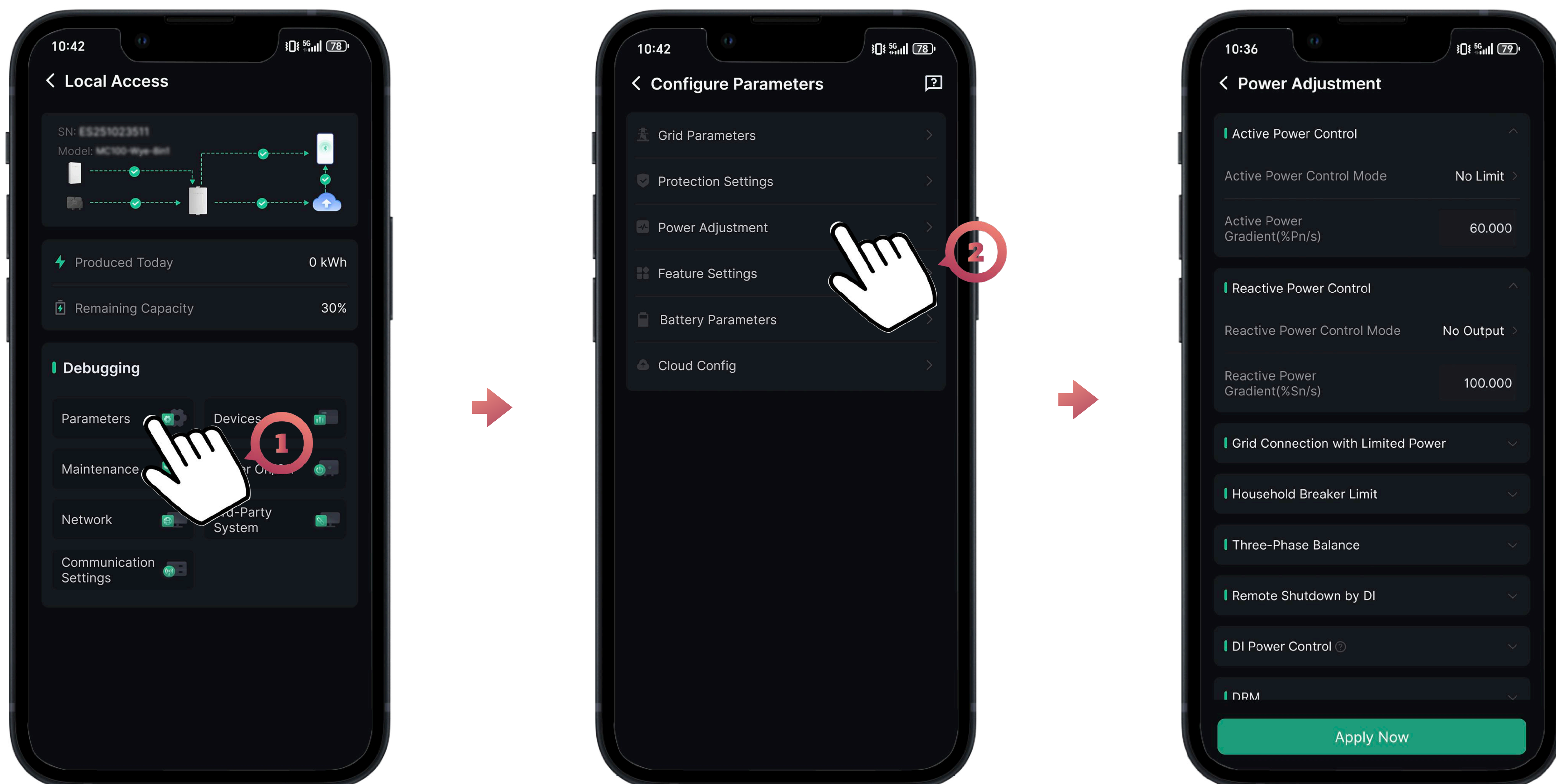

B. Active Power Control

a. Tap Active Power Control Mode to do advanced settings.

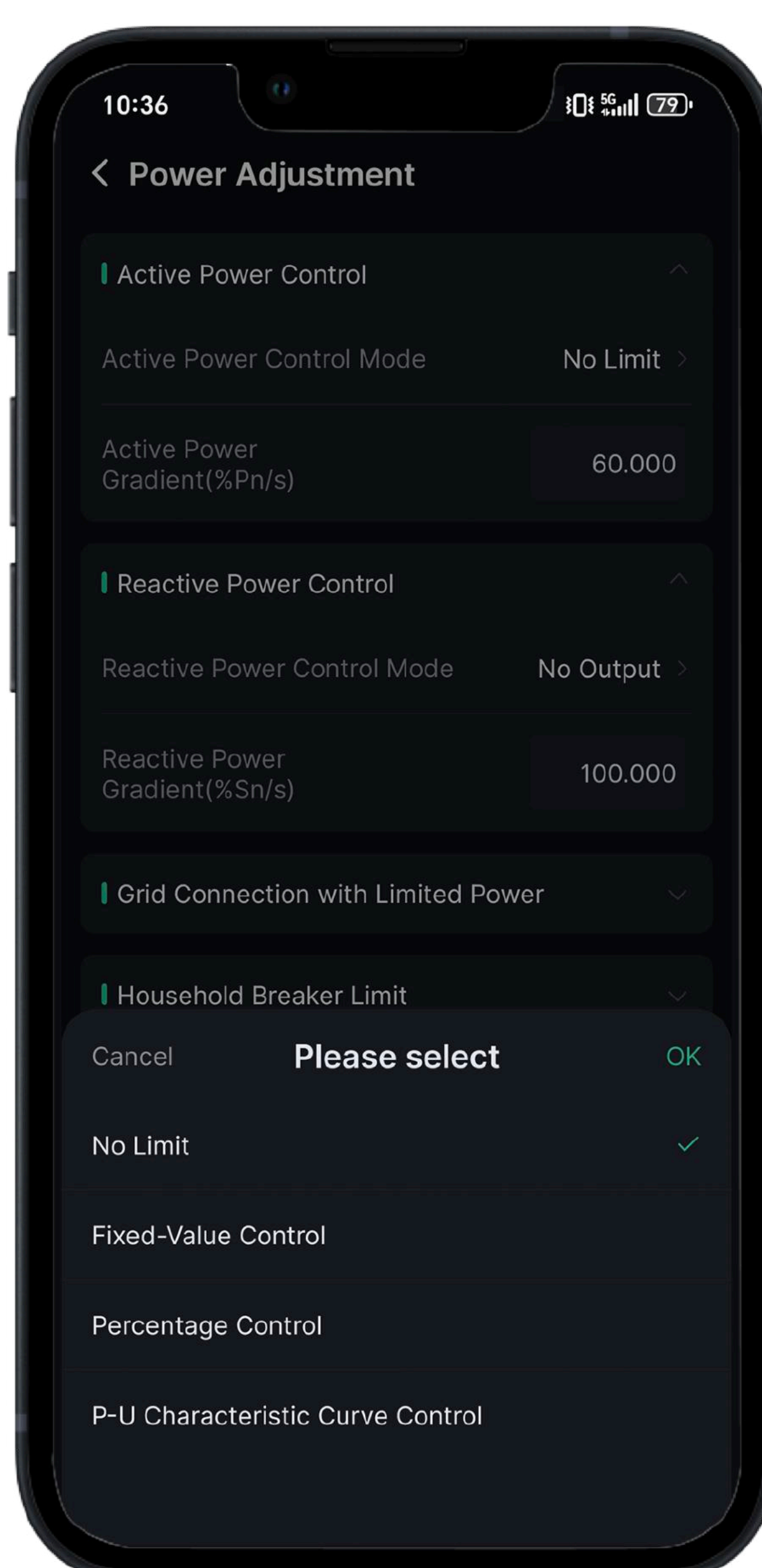

Active Power Control settings List

Parameter Name	Unit	Value Range
No Limit		
Active Power Control Mode		No Limit
Active Power Gradient	%Pn/s	0.000 to 1000.000
Fixed-Value Control		
Active Power Control Mode		Fixed-Value Control
Active Power Fixed-Value Scheduling	kW	-1000.0000 to 1000.0000
Active Power Gradient	%Pn/s	0.000 to 1000.000
Percentage Control		
Active Power Control Mode		Percentage Control
Active Power Percentage Scheduling	%	0.0 to 100.0
Active Power Gradient	%Pn/s	0.000 to 1000.000
P-U Characteristic Curve Control		
Active Power Control Mode		P-U Characteristic Curve Control
Response Time of Active Power of P-U Curve	s	0 to 600
Entry Voltage Threshold of P-U Curve	%	0.0 to 150.0
Exit Voltage Threshold of P-U Curve	%	0.0 to 150.0
P-U Characteristic Curve Points		2 to 10
P/Pn		-1.000 to 1.000
U/Un	%	0.0 to 130.0
Active Power Gradient	%Pn/s	0.000 to 1000.000

C. Reactive Power Control

- a. Tap Reactive Power Control Mode to do advanced settings.

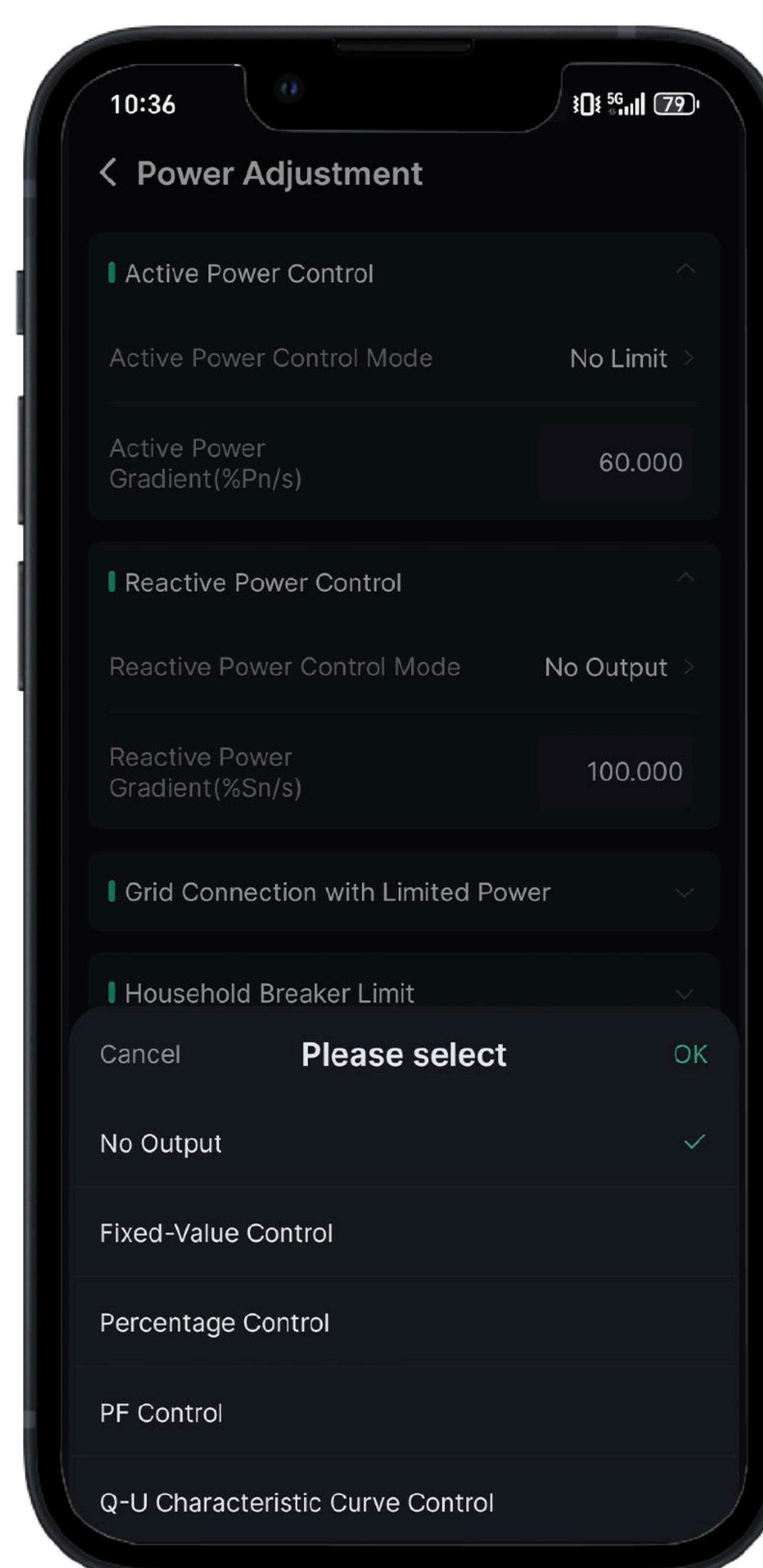

Reactive Power Control settings List

Parameter Name	Unit	Value Range
No Output		
Reactive Power Control Mode		No Output
Reactive Power Gradient	%Sn/s	0.000 to 1000.000
Fixed-Value Control		
Reactive Power Control Mode		Fixed-Value Control
Reactive Power Fixed-Value Scheduling	kVar	-1000.0000 to 1000.0000
Reactive Power Fixed-Value Scheduling Response Time	s	0 to 600
Reactive Power Gradient	%Sn/s	0.000 to 1000.000
Percentage Control		
Reactive Power Control Mode		Percentage Control
Reactive Power Percentage Scheduling	%	-100.0 to 100.0
Reactive Power Fixed-Value Scheduling Response Time	s	0 to 600
Reactive Power Gradient	%Sn/s	0.000 to 1000.000
PF Control		
Reactive Power Control Mode		PF Control
Reactive Power PF Scheduling		-1.000 to -0.8000, 800 to 1.000
Reactive Power Fixed-Value Scheduling Response Time	s	0 to 600
Reactive Power Gradient	%Sn/s	0.000 to 1000.000

Parameter Name	Unit	Value Range
Q-U Characteristic Curve Control		
Reactive Power Control Mode		Q-U Characteristic Curve Control
Response Time of Active Power of Q-U Curve	s	0 to 600
Minimum PF of Q-U Curve		0.000 to 1.000
Entry Active Power Threshold of Q-U Curve	kW	0.000 to 1000.000
Exit Active Power Threshold of Q-U Curve	kW	0.000 to 1000.000
Active Power Threshold for Effective Minimum PF of Q-U Curve	%	0.0 to 100.0
Q-U Characteristic Curve Points		2 to 10
Q/S		-1.000 to 1.000
U/Un	%	0.0 to 130.0
Reactive Power Gradient	%Sn/s	0.000 to 1000.000
cosϕ-P/Pn Characteristic Curve Control		
Reactive Power Control Mode		cos ϕ -P/Pn Characteristic Curve Control
Entry Voltage Threshold of cos ϕ -P/Pn Curve	V	0.0 to 345.0
Exit Voltage Threshold of cos ϕ -P/Pn Curve	V	0.0 to 345.0
Response Time of Reactive Power of cos ϕ -P/Pn Characteristic Curve	s	0 to 600
cos ϕ -P/Pn Characteristic Curve Points		2 to 10
Cos ϕ		-1.000 to 1.000
P/Pn	%	0.0 to 100.0
Reactive Power Gradient	%Sn/s	0.000 to 1000.000
Q/Sn-P/Pn Characteristic Curve Points		
Reactive Power Control Mode		Q/Sn-P/Pn Characteristic Curve Points
Q/Sn-P/Pn Characteristic Curve Points		2 to 10
Q/Sn	%	-100.0 to 100.0
P/Pn	%	0.0 to 100.0
Reactive Power Gradient	%Sn/s	0.000 to 1000.000
cosϕ-U/Un Characteristic Curve Control		
Reactive Power Control Mode		cos ϕ -U/Un Characteristic Curve Control
Entry Voltage Threshold of cos ϕ -U/Un Curve	%	0.0 to 150.0
Exit Voltage Threshold of cos ϕ -U/Un Curve	%	0.0 to 150.0
cos ϕ -U/Un Characteristic Curve Points		2 to 10
Cos ϕ		-1.000 to 1.000
U/Un	%	0.0 to 150.0
Reactive Power Gradient	%Sn/s	0.000 to 1000.000

D. Grid Connection with Limited Power (Export Limit Control)

- a. Tap Grid Connection with Limited Power Mode to do advanced settings.

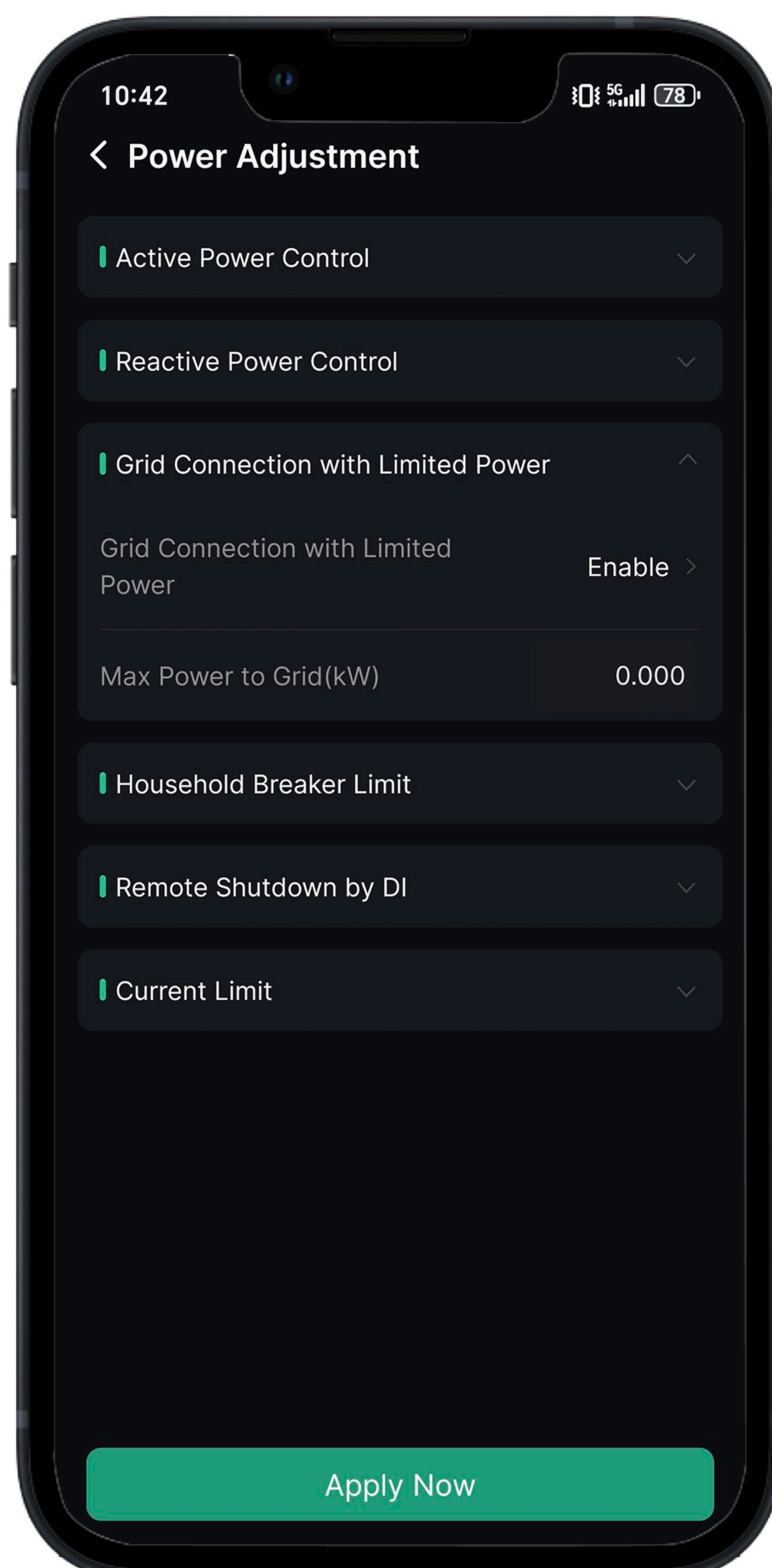

Grid Connection with Limited Power settings List

Parameter Name	Unit	Value Range
Grid Connection with Limited Power		
Grid Connection with Limited Power		Disable/Enable
Max Power to Grid	kW	0.000 to 1000.000

8.2.5 Maximum Output Power Settings

a. Tap Maximum output power to access the parameters setting screen.

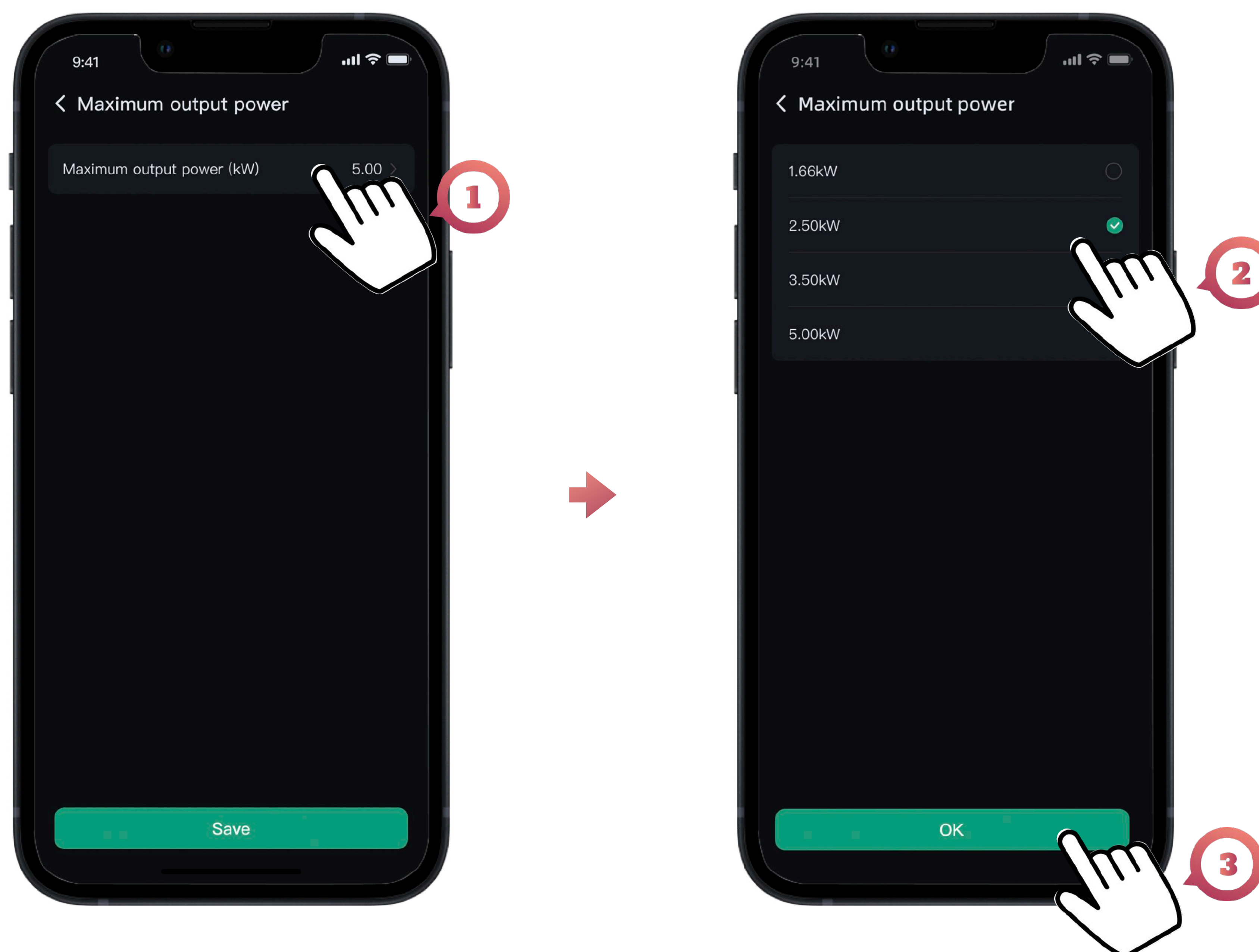

Maximum Output Power List

Parameter Name	Unit	Value Range
Maximum Output Power		
Maximum Output Power	kW	1.66 2.50 3.50 5.00

8.3 System Power-Off

8.3.1 Prerequisites



- Wear personal protective equipment and use dedicated insulated tools to avoid electric shocks or short circuits.

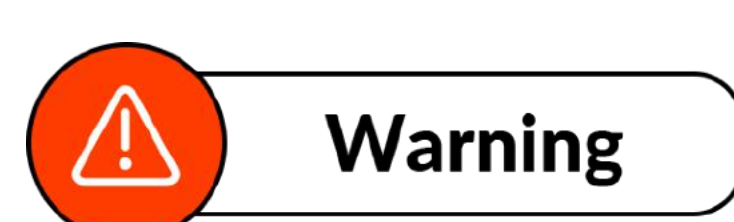

- Before performing maintenance, power off the equipment, follow the instructions on the delayed discharge label, and wait for a period of time as specified to ensure that the equipment is not energized.

8.3.2 Precautions

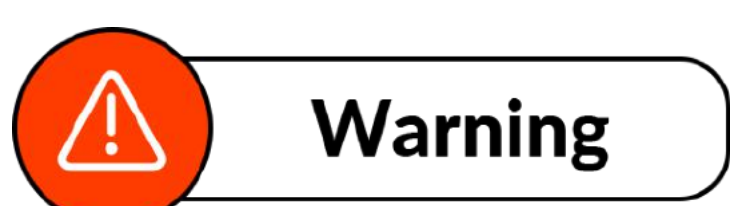

- Before performing maintenance, power off the equipment, follow the instructions on the delayed discharge label, and wait for a period of time as specified to ensure that the equipment is not energized.

8.3.3 Procedure

Section A. MS-7K-U-1P/ MS-7K-U-3P Power-Off Only

- a. Send a shutdown command on the app.
- b. Turn off the breaker of the battery in the distribution panel.

Section B. MS-7K-U-1P + MC100PRO-S1P / MS-7K-U-3P + MC100PRO-T3P Power-Off

- a. Send a shutdown command on the app via bluetooth connection.
- b. Disconnect the main circuit breaker in the distribution panel.
- c. Open the door of the MC100PRO and turn off all the breakers in the combiner.

8.4 Routine Maintenance

To ensure that the MS-7K-U-1P/ MS-7K-U-3P /MS-7K-U-1P + MC100PRO-S1P / MS-7K-U-3P + MC100PRO-T3P can operate properly for a long term, you are advised to perform routine maintenance on it as described in this chapter.

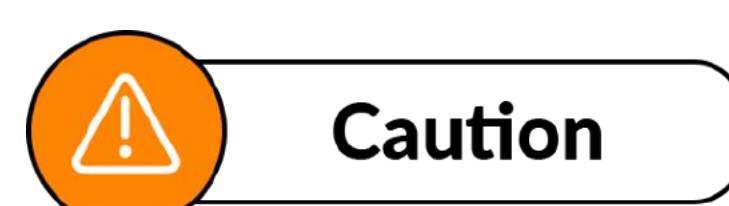

- Before cleaning the system, connecting cables, and maintaining the grounding reliability, power off the system.

8.4.1 Maintenance list





Check Detail	Check Method	Maintenance Interval
System running status	Check the devices for damage or deformation.	Annual
Electrical connections	<ul style="list-style-type: none"> • Cables are securely connected. • Cables are intact, in particular, the parts touching the metallic surface are not scratched. 	The first inspection is 6 months after the initial commissioning. From then on, the interval can be 6 to 12 months.
Grounding reliability	Check whether the ground terminal and ground cable are securely connected.	Annual

Troubleshooting

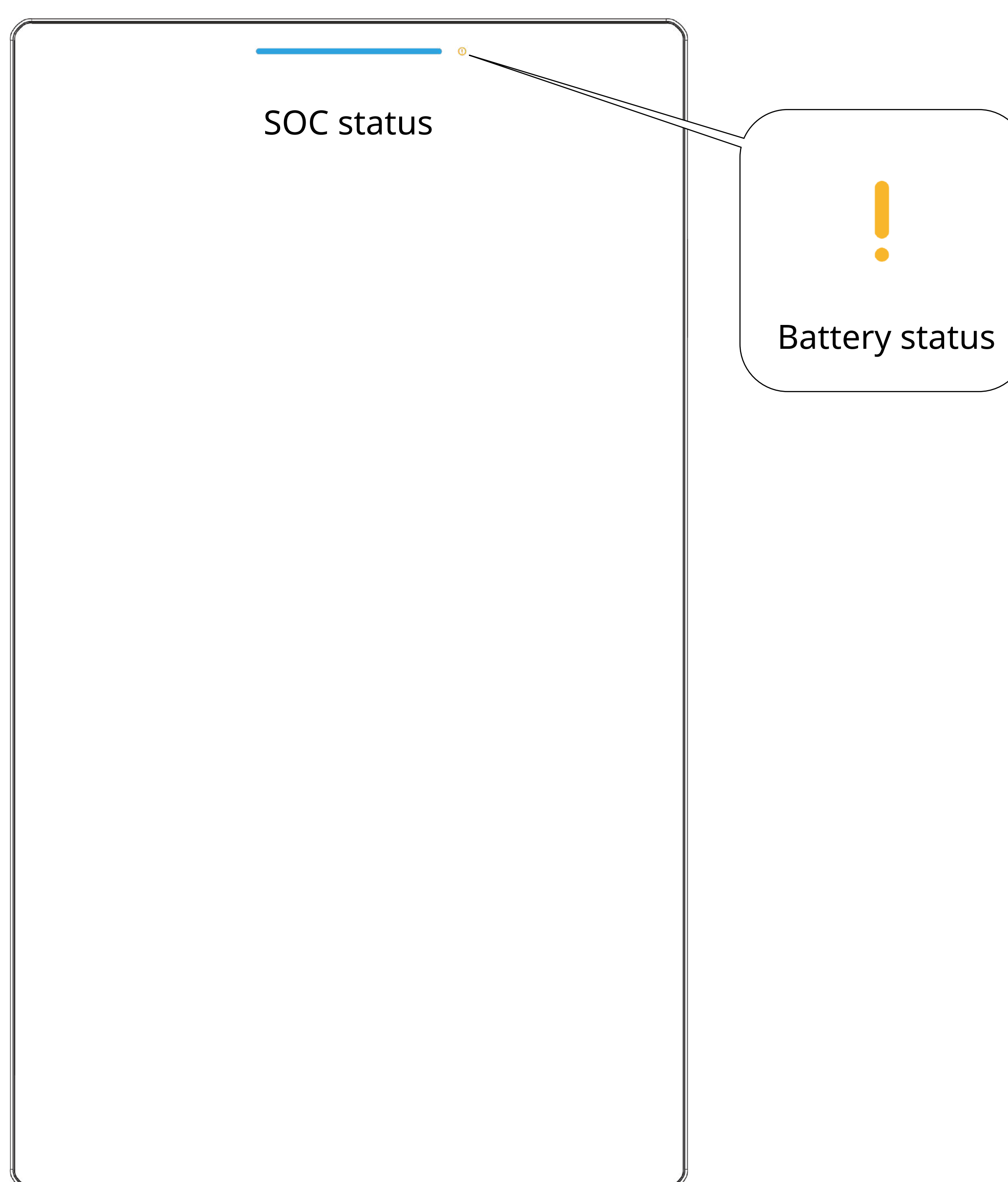
9.1 LED Indicator Description

The M-battery has two types of LEDs and the following table describes their status.



Function	Colour		Description
SOC status	Solid blue		Remaining battery energy percentage
Battery status	Quick flash		Abnormal working condition
	Solid red		The battery has an internal fault
	Dim		Normal operation

NOTE:

- When the M-ELV battery is powered on for the first time, powered on after long-term storage, or left in standby mode for an extended period of time, this may cause deviations in SOC accuracy. It is recommended to charge the system to SOC=100% at least once to calibrate SOC accuracy.

9.2 Check the alert Codes

The device error codes can be viewed through the following steps in the ATMOZEN app:

- Tap Status of the site.
- Select the faulty device to check the details.

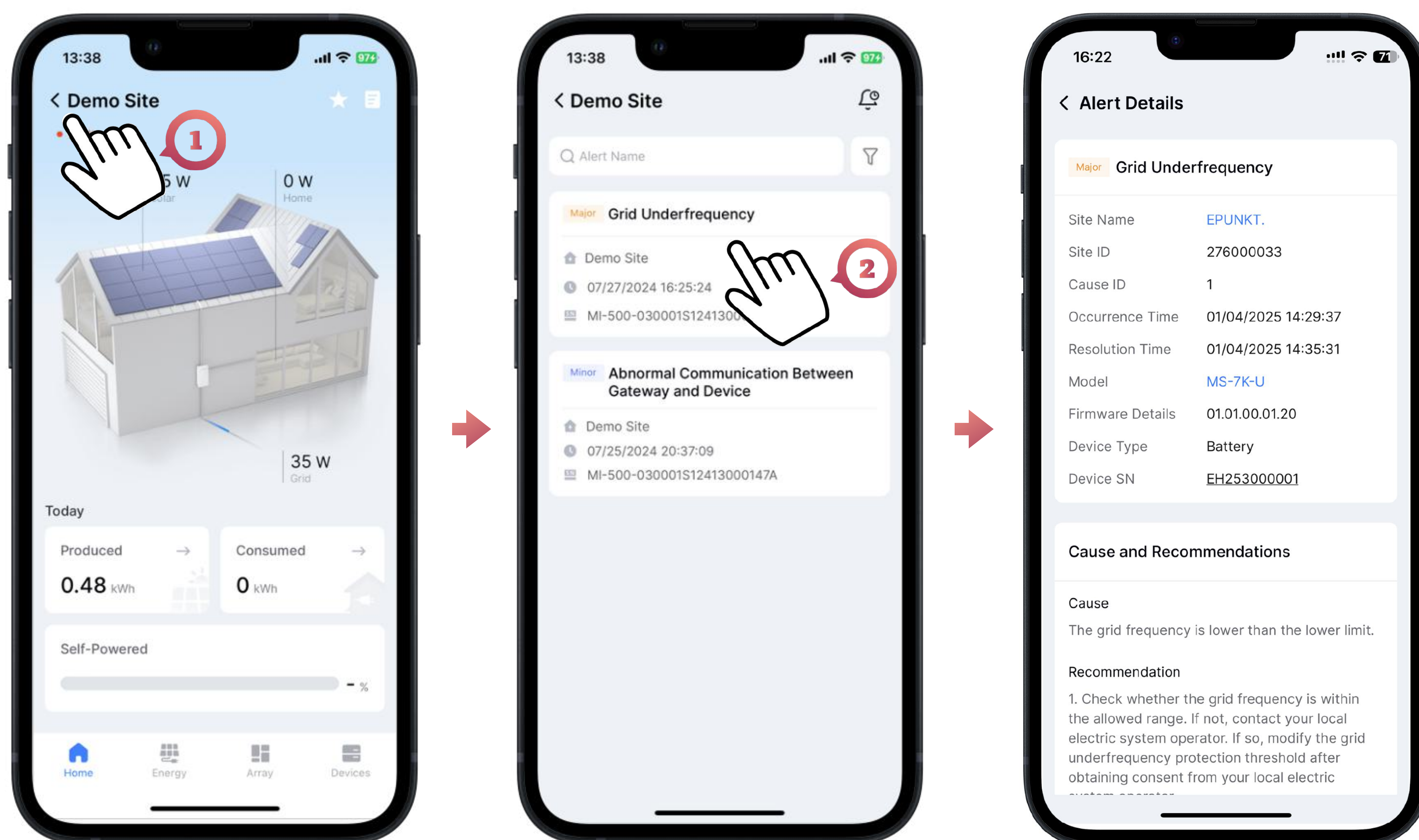

NOTE:

- The alert code check can be performed only after the system has been activated via the ATMOZEN app.
- Alert codes can be checked only when the site status is 'Faulty' or 'Offline'.

9.3 Alert Codes List

Code	Issue	Cause	Solution
2	Grid Power Outage	Grid power outage occurred.	<ul style="list-style-type: none"> • Check whether the grid is normally powered. • Check whether the alternating current cable or breaker is disconnected.
3	Grid Undervoltage	The grid voltage is lower than the lower limit.	<ul style="list-style-type: none"> • Check whether the grid voltage is within the allowed range. If not, contact your local electric system operator. If so, modify the grid undervoltage protection threshold after obtaining consent from your local electric system operator. • If the fault persists, check whether the alternating current breaker and cable are connected properly.
4	Grid Overvoltage	The grid voltage is higher than the upper limit.	<ul style="list-style-type: none"> • Check whether the grid voltage is within the allowed range. If not, contact your local electric system operator. If so, modify the grid overvoltage protection threshold after obtaining consent from your local electric system operator. • If the fault persists, check whether the alternating current breaker and cable are connected properly, or whether the cable complies with the recommended specifications.
5	Grid Underfrequency	The grid frequency is lower than the lower limit.	<ul style="list-style-type: none"> • Check whether the grid frequency is within the allowed range. If not, contact your local electric system operator. If so, modify the grid underfrequency protection threshold after obtaining consent from your local electric system operator.
6	Grid Overfrequency	The grid frequency is higher than the upper limit.	<ul style="list-style-type: none"> • Check whether the grid frequency is within the allowed range. If not, contact your local electric system operator. If so, modify the grid overfrequency protection threshold after obtaining consent from your local electric system operator.
7	High Output Direct Current Component	The output direct current component is higher than the upper limit.	<ul style="list-style-type: none"> • The device automatically monitors external working conditions in real time and returns to normal after the fault is resolved. • If the fault occurs frequently, contact your distributor or Customer Service.

Code	Issue	Cause	Solution
13	Distribution error occurred.	<ol style="list-style-type: none"> 1. Abnormal phase in the single-phase system. 2. Phase loss in the three-phase system. 3. Reversed phase sequence in the three-phase system. 4. Short circuit in the three-phase system. <p>N line not effectively grounded, voltage present to PE</p> <p>The single-/three-phase wiring in the battery is inconsistent with the single-/three-phase configuration in the combiner.</p>	<ul style="list-style-type: none"> • For single-phase battery, check for a short circuit in the AC input. • For three-phase battery, check for phase loss, reversed phase sequence, or short circuits in the AC wiring. • If the alert persists, contact your distributor or Customer Service. • 1. Please ensure that the N line is reliably grounded. • 2. If the alarm persists, please contact the dealer/customer service center. • Please check whether the AC distribution wiring of the battery is consistent with the single/three-phase configuration in the combiner. • If the alert persists, contact your distributor or Customer Service.
18	High Output DC Voltage Component	The output DC voltage component is higher than the upper limit.	<ul style="list-style-type: none"> • The device automatically monitors external working conditions in real time and returns to normal after the fault is resolved. • If the fault occurs frequently, contact your distributor or Customer Service.
50	Battery Overvoltage	The total battery voltage or battery cell voltage exceeds the alert threshold.	<ul style="list-style-type: none"> • In the app, shut down the battery and then power it on again; • Reset the system in the app; • If the battery is connected to the grid, disconnect the AC input, wait for the battery indicator to go out, and then restore the AC input; • If the alert persists, contact your distributor or Customer Service.
51	Battery Undervoltage	<p>The total battery voltage is below the alert threshold.</p> <p>The voltage of a battery cell is too low.</p>	<ul style="list-style-type: none"> • If the battery is connected to the grid, disconnect the AC input, wait for the battery indicator to go out, and then restore the AC input; • Reset the system in the app; • If the alert persists, contact your distributor or Customer Service. • If the battery is connected to the grid, disconnect the AC input, wait for the battery indicator to go out, and then restore the AC input; • Reset the system in the app; • If the alert persists, contact your distributor or Customer Service.
52	Large Battery Cell Voltage Difference	The voltage difference between battery cells exceeds the alert threshold.	<ul style="list-style-type: none"> • If the battery is connected to the grid, disconnect the AC input, wait for the battery indicator to go out, and then restore the AC input. • Reset the system in the app. • If the alert persists, contact your distributor or Customer Service.
53	Battery Overtemperature	<ol style="list-style-type: none"> 1. The battery temperature exceeds the alert threshold 2. The ambient temperature is too high. 3. The fan is not working normally. 	<ul style="list-style-type: none"> • Wait for a while and check if the alert disappears automatically. • If the alert is reported frequently, please ensure that the working conditions of the device are within the allowed range. • If the alert persists, contact your distributor or Customer Service.

Code	Issue	Cause	Solution
54	Low Battery Temperature	<ol style="list-style-type: none"> 1. The battery temperature is below the alert threshold. 2. The ambient temperature is too low. 3. The heating system is not working normally. 	<ul style="list-style-type: none"> • Please ensure that the working conditions of the device are within the allowed range. • If the alert persists, contact your distributor or Customer Service.
55	Large Battery Cell Temperature Difference	<ol style="list-style-type: none"> 1. The temperature difference between battery cells exceeds the alert threshold. 2. The fan is not working normally. 	<ul style="list-style-type: none"> • Shut down the battery and then power it on again. • Reset the system. • If the alert is reported frequently, contact your distributor or Customer Service.
56	Battery Overcurrent	The battery current exceeds the alert threshold.	<ul style="list-style-type: none"> • Wait for a while and check if the alert disappears automatically. • If the alert is reported frequently, reset the system in the app. • If the alert persists, contact your distributor or Customer Service.
57	Low Battery SOH	The battery health metric is below the alert threshold.	<ul style="list-style-type: none"> • The battery lifespan has reached its end. Please stop using the battery. • Please follow the legal regulations in your country/region and contact local battery recycling services for disposal.
58	Battery Life Terminated	The battery lifespan has reached its end.	<ul style="list-style-type: none"> • The battery lifespan has reached its end. Please stop using the battery. • Please follow the legal regulations in your country/region and contact local battery recycling services for disposal.
59	Battery Micro-Short Circuit	The battery micro-short circuit fault occurred.	<ul style="list-style-type: none"> • Please contact your distributor or Customer Service.
60	Battery Thermal Runaway	The battery thermal runaway fault occurred.	<ul style="list-style-type: none"> • Please immediately disconnect the battery AC input and stop using the battery. • Please contact your distributor or Customer Service.
62	Internal Device Error	<p>The internal circuit fault protection of the battery is triggered.</p> <p>The internal circuit of the battery failed.</p>	<ul style="list-style-type: none"> • In the app, shut down the battery and then power it on again; • Reset the system in the app; • If the battery is connected to the grid, disconnect the AC input, wait for the battery indicator to go out, and then restore the AC input; • If the alert persists, contact your distributor or Customer Service. • In the app, shut down the battery and then power it on again; • Reset the system in the app; • If the battery is connected to the grid, disconnect the AC input, wait for the battery indicator to go out, and then restore the AC input; • If the alert persists, contact your distributor or Customer Service.
63	Abnormal Communication Between Battery and Gateway	<ol style="list-style-type: none"> 1. The device is shut down. 2. The CAN bus cable between the device and the gateway is abnormal. 	<ul style="list-style-type: none"> • Please ensure that the CAN bus cable between the gateway and battery module is reliably connected. • Reset the system. • If the alert persists, contact your distributor or Customer Serv
64	Active Device Protection	The operating environment of the battery is abnormal.	<ul style="list-style-type: none"> • The device automatically monitors external working conditions and returns to normal after the fault is resolved. • If the alert is reported frequently, contact your distributor or Customer Service.

9.4 Maintenance

9.4.1 How to shut down

- After entering the interface shown in Figure 1, click 'Power on/off'.
- Then, in the Figure 2 interface, click 'Shut down'.

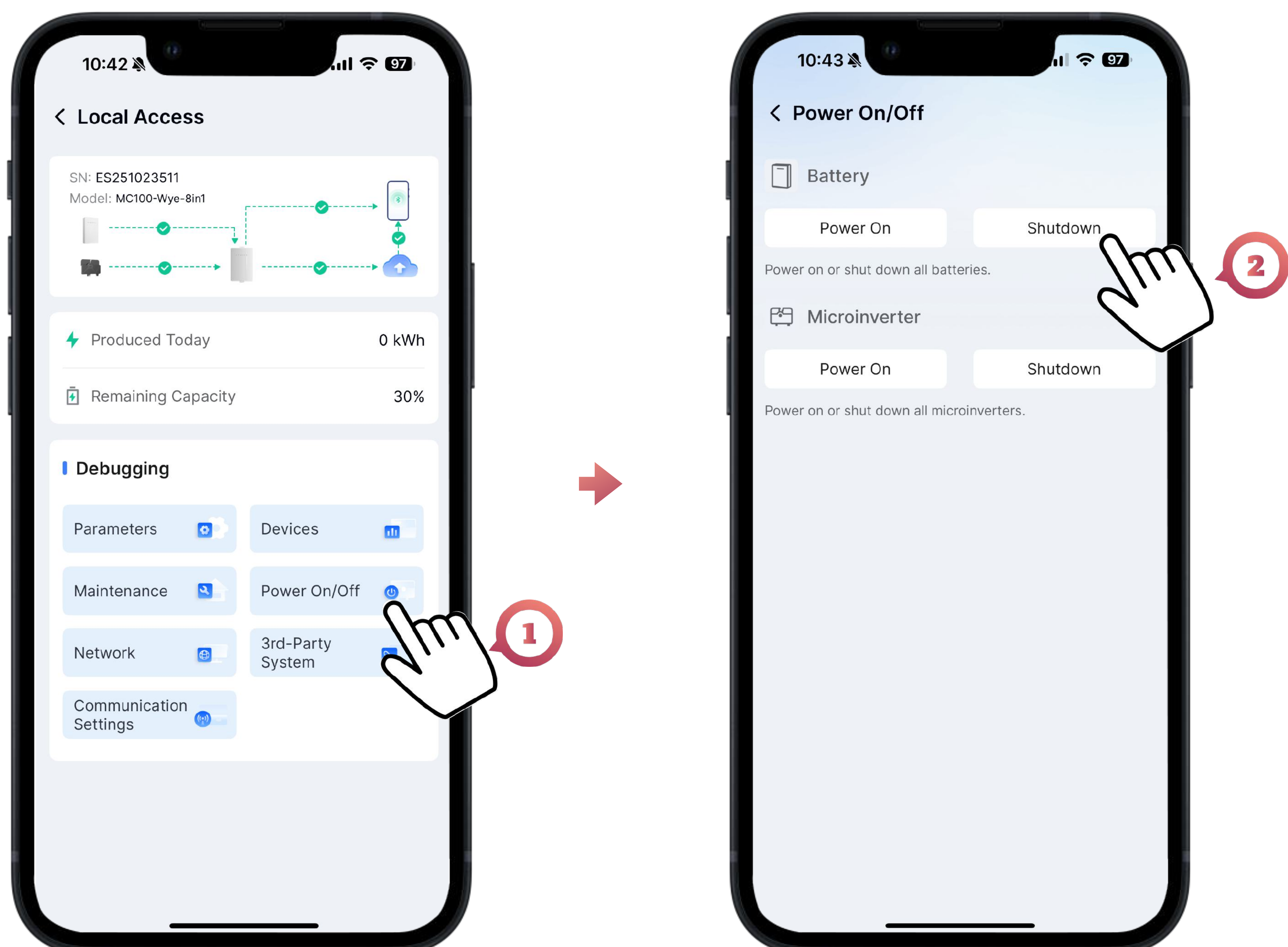

9.4.2 How to reset

Section A: System Reset

- After entering the interface shown in Figure 1, click 'Maintenance'.
- After entering the interface shown in Figure 2, click 'System Reset'.
- Then, in the Figure 3 interface, Login Password and start system reset.

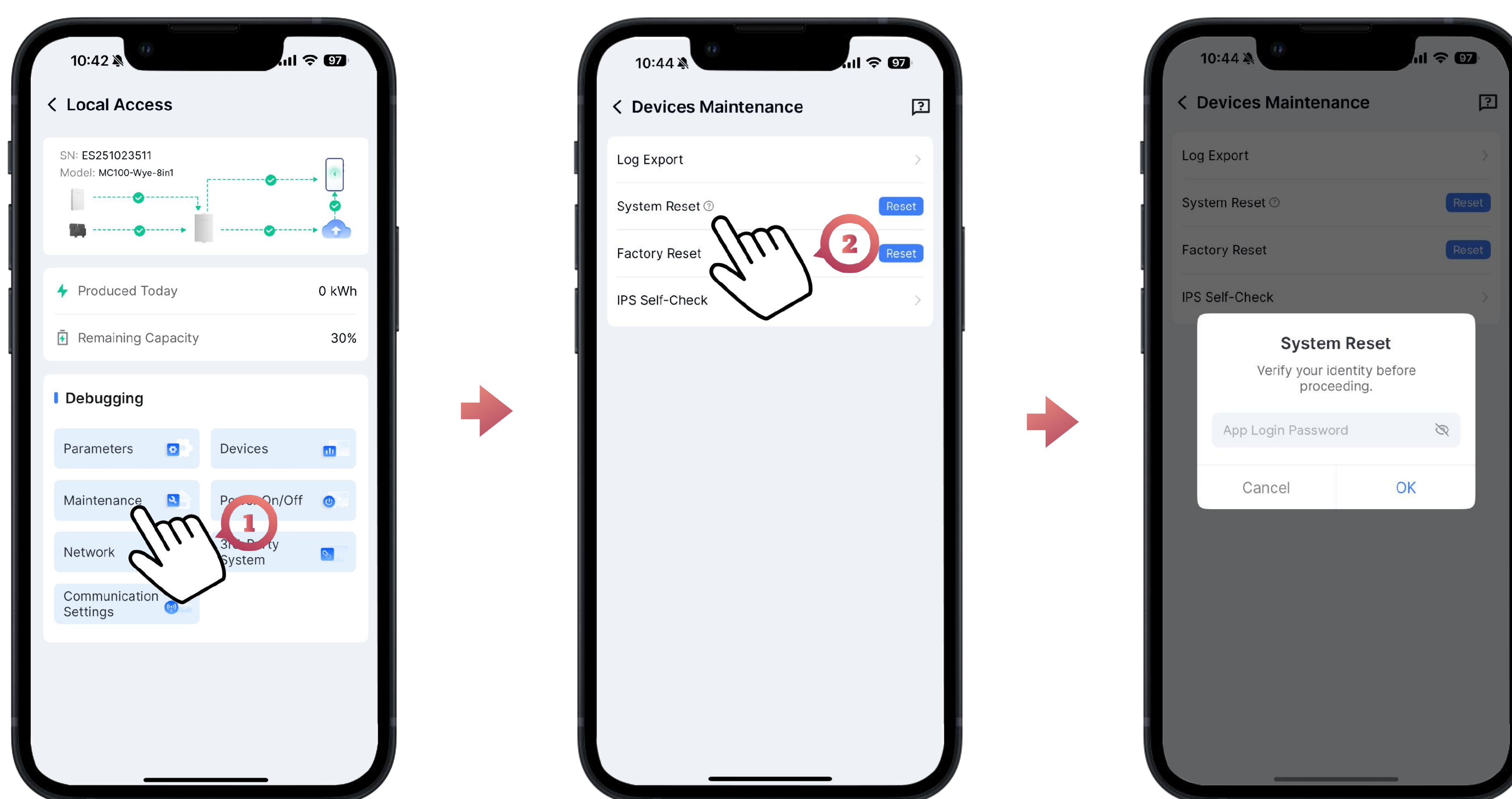

Section B: How to Factory Reset

- After entering the interface shown in Figure 1, click 'Maintenance'.
- After entering the interface shown in Figure 2, click 'Factory Reset'.
- Then, in the Figure 3 interface, choose Battery.
- In the end, in the Figure 4 interface, Login Password and start system reset.

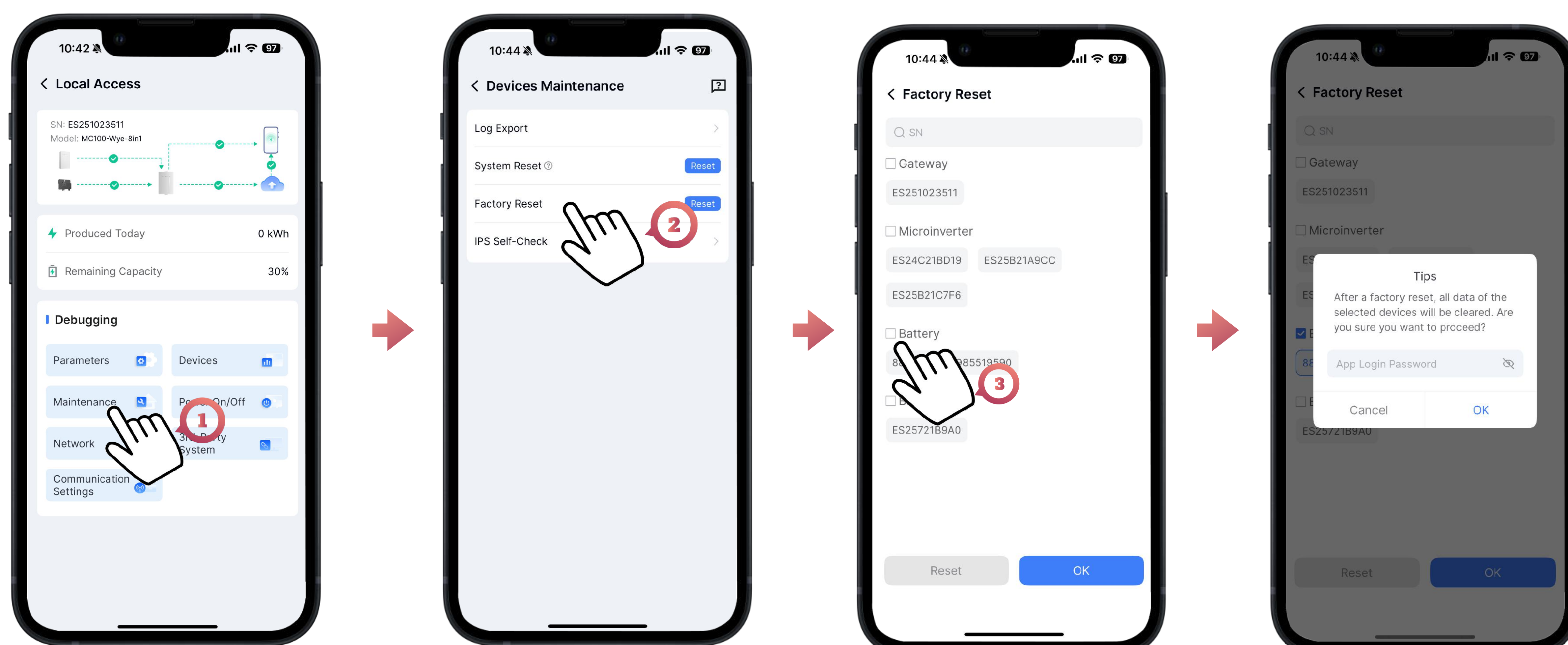

9.4.3 How to export logs

- After entering the interface shown in Figure 1, click 'Maintenance'.
- Then, in the Figure 2 interface, choose 'All logs' or 'Partial logs' as needed.

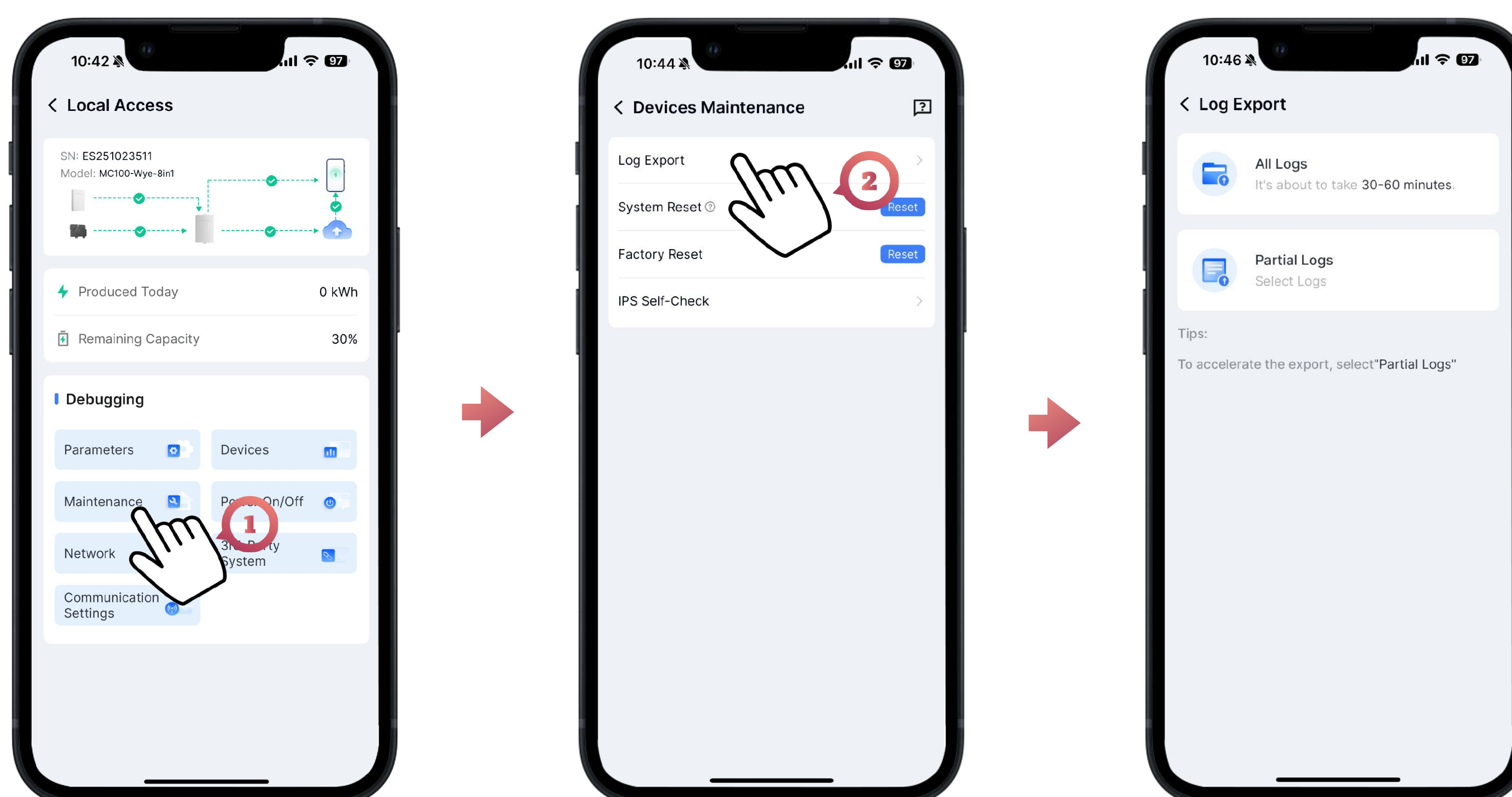

9.4.4 How to set parameters

- After entering the interface shown in Figure 1, click 'Parameters'.
- Then, click 'Grid Parameters' in Figure 2.
- Finally, change parameters and then click 'Apply Now'.

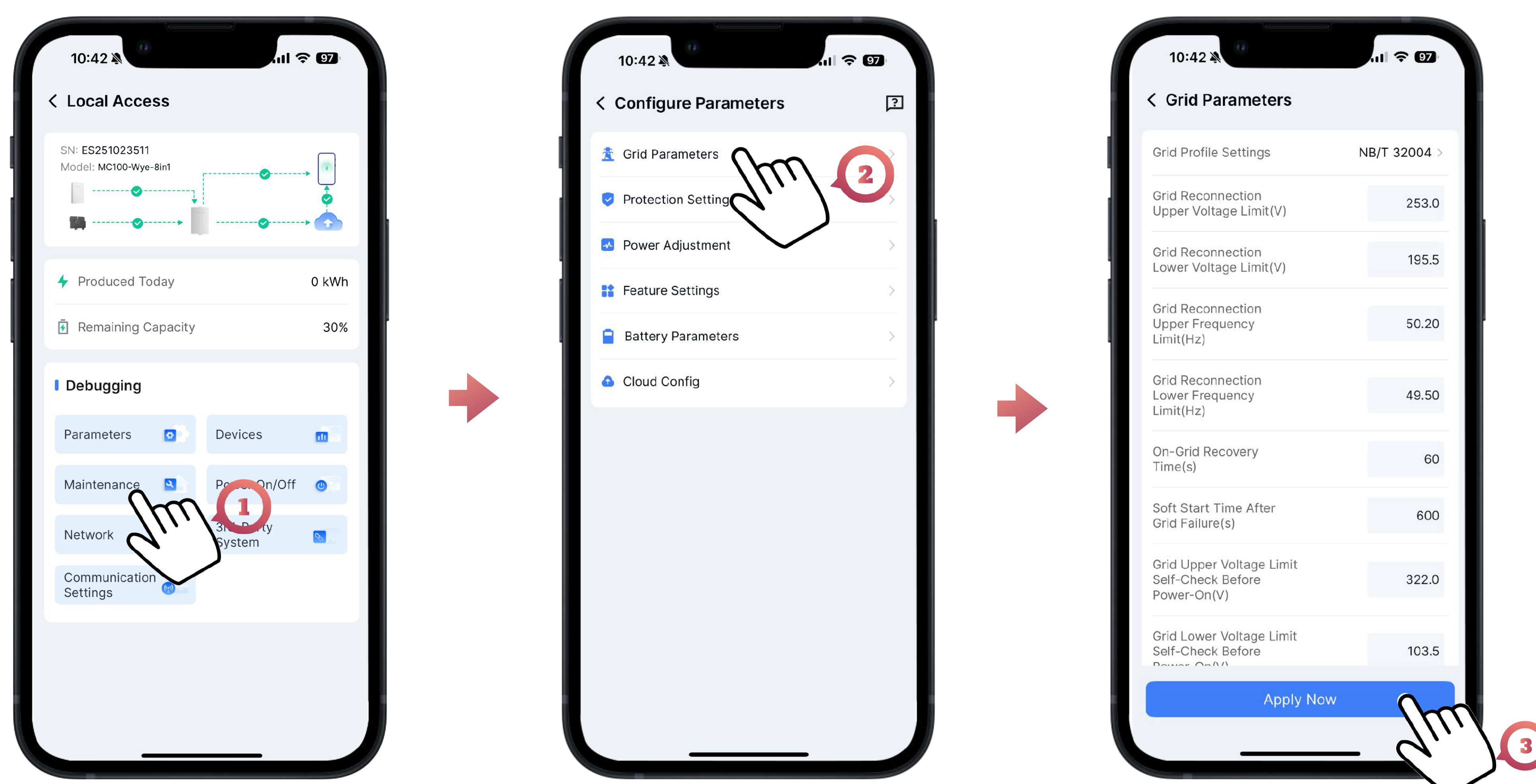

Technical Data

Based on the instruction to reference the parameter information for the individual components, the details are organized as follows:

Combination 1: MS-7K-U-1P + MC100PRO-S1P

(Referencing the parameter information for the MS-7K-U-1P and the MC100PRO-S1P below)

- a. Main Unit Model: MS-7K-U-1P
- b. Parameter Information: [Refer to the specific data for MS-7K-U-1P]
- c. Matching Component Model: MC100PRO-S1P
- d. Parameter Information: [Refer to the specific data for MC100PRO-S1P]

Combination 2: MS-7K-U-3P + MC100PRO-T3P

(Referencing the parameter information for the MS-7K-U-3P and the MC100PRO-T3P below)

- a. Main Unit Model: MS-7K-U-3P
- b. Parameter Information: [Refer to the specific data for MS-7K-U-3P]
- c. Matching Component Model: MC100PRO-T3P
- d. Parameter Information: [Refer to the specific data for MC100PRO-T3P]

10.1 MS-7K-U-1P / MS-7K-U-3P Data Sheet

Items	Unit	MS-7K-U-1P	MS-7K-U-3P
Electrical Parameters			
Rated output apparent power	kVA		4.5
Max. output power	kVA		5
Max. continuous input power	kVA		3.75
Nominal voltage	V _{a.c.}	1/N/PE ~ 230	3/N/PE ~ 230/400
Operating voltage range (L to N)	V _{a.c.}		176 - 276
Backfeed short-circuit current	A	27.27	9.09
Maximum short circuit current	A	27.27	9.09
Nominal frequency	Hz		50
Frequency range	Hz		45-55 @50 Hz
Max. input current	A	16.30 @ 230 Va.c.	16.30 @ 230 Va.c., 5.41 @ 400 Va.c.
Max. output current	A	21.74 @ 230 Va.c.	21.74 @ 230 Va.c., 7.25 @ 400 Va.c.
Power factor (adjustable)			0.8 leading...0.8 lagging
Max. Battery Continuous Charging Current	A		235 (DC)
Max. Battery Continuous Discharging Current	A		270 (DC)
AC round-trip efficiency	%		90 ^a
THDi	%		<3
Battery			
Total energy capacity	kWh		7.168
Rated battery energy	kWh		7
Usable battery capacity	kWh		7
Nominal battery capacity	Ah		280
Nominal DC voltage	V		25.6
Max. DC voltage	V		28.8
Chemistry			Lithium iron phosphate (LFP)
Number of cycles			10,000
Battery depth of discharge	%		100 ^b
DC round-trip efficiency	%		96
Mechanical data			
Dimensions (without bracket)	mm		830 × 480 × 195 (H x W x D)
Lifting weight (without bracket)	kg		73.5
Mounting			Floor or wall mount
Ambient operating temperature range	°C		-20 to 55
Optimum operating temperature range	°C		0 to 30
Storage temperature	°C		-20 to 55
Protection class			I
Ingress Rating			IP66
Cooling			Intelligent air cooling
Operating Humidity (RH)	%		4 to 100, condensing
Altitude	m		Up to 3,000
Pollution Rating			PD3
Operation Noise	dB		< 35

a. Limited by the ambient temperature of the battery, the maximum operating ambient temperature is 55 °C for outdoor unconditioned with solar effects.

b. For usable battery capacity, our DoD is 100%, while for total energy capacity, it is 98%.

Items	Unit	MS-7K-U-1P	MS-7K-U-3P
Protection			
AC port overvoltage class			III
AC surge protection			TYPE II
Galvanic Isolation			YES
Insulation resistance monitor			YES
Anti-islanding Protection			Yes (frequency shift)
Features and compliance			
Indicator			LEDs for SOC & Status
Communication			CAN
Backup		Support with MC100PRO-S1P	Support with MC100PRO-T3P
Services ^c			Self-consumption, TOU, Grid ancillary services
Cloud Service			ATMOCE Cloud & ATMOZEN APP
Compliance		IEC 62619, ISO 13849, IEC 61000-6-1, IEC 61000-6-3, IEC 63056, IEC 62477-1, VDE- AR-E 2510-50, AS/NZS 4777.2	
Country of manufacture			China

c. Work together with ATMOCE Gateway.

10.2 MC100PRO-S1P / MC100PRO-T3P Data Sheet

Items	Unit	MC100PRO-T3P	MC100PRO-S1P
What's in the combiner PRO			
M-Gateway MG100			1 × MG100
Gateway Breaker		1 × unit, 10 A, 3-pole	1 × unit, 10 A, 1-pole
PV Inverter-side Breaker ^a		1 × unit, 50 A, 3-pole	2 × unit, 50 A, 1-pole
PV Inverter-side Rated Input Current	A		40
PV Inverter-side Rated Input Apparent Power	VA	27600	9200
Grid-side Breaker		1 × unit, 63 A, 3-pole	1 × unit, 63 A, 1-pole
Grid-side Rated Input/Output Current	A		50
Non Backup terminal		1 × unit, 3-pole	1 × unit, 1-pole
Non Backup Rated Output Current	A		50
Non Backup Rated Output Apparent Power	VA	34500	11500
Battery-side Breaker		1 × unit, 63 A, 3-pole	1 × unit, 63 A, 1-pole
Battery-side Rated Input/Output Current	A		50
Battery-side Rated Input/Output Apparent Power	VA	34500	11500
Bypass breaker		1 × unit, 63 A, 3-pole	1 × unit, 63 A, 1-pole
Backup Port breaker		1 × unit, 63 A, 3-pole	1 × unit, 63 A, 1-pole
Backup Port Rated Output Current	A		50
Backup Port Rated Output Apparent Power	VA	34500	11500
PV Inverter CT		3 × CTs, accurate up to 0.1%	1 × CT, accurate up to 0.1%
Battery CT		3 × CTs, accurate up to 0.1%	1 × CT, accurate up to 0.1%
Consumption CT interface		3 × CTs, accurate up to 0.1%	1 × CT, accurate up to 0.1%
Electrical parameters			
Grid setup		Three-phase	Single-phase
Nominal voltage	V	380/400/415Va.c.	220/230/240Va.c.
Operating voltage range (L to N)	V		176 to 276
Nominal frequency	Hz		50/60
Extended frequency range	Hz		45 to 65
Power factor range			1 leading...1 lagging
Maximum Output Fault Current	A	10.12	28.71
Overvoltage category			III
Mechanical parameters			
Dimensions (W × H × D)	mm	475 × 690 × 150	420 × 550 × 150
Weight	kg	19	11
Ambient temperature range	°C		-30 to 50
Cooling			Natural convection
Enclosure environmental rating			Outdoor, IP65
Wire sizes ^b	mm ²	PV side: 6 to 16 Grid side: 6 to 16 Battery side: 2.5 to 16	
Communication cable sizes	mm ²	0.25 to 0.75	
Communication		PLC, Wi-Fi, BLE, ETH, CAN, RS485	
Noise	dB		<35
Altitude	m		3000
Protection class			II
Pollution degree			III

Items	Unit	MC100PRO-T3P	MC100PRO-S1P
Communication interfaces			
Grid side	DRM0		Support
Battery side	CAN		Support
Load side	ETH	1 × interface, 100 Mb/10 Mb auto-adaptability	
	Digital I/O		4 × 12 V DO, 3 × DI
	RS485		Support
	Digital I/O for Generator		1 × DO, 1 × DI, 1 × RS485
Atmoce-Cloud	Wi-Fi		2.4 GHz
	ETH	1 × interface, 100 Mb/10 Mb auto-adaptability	
Atmozen app	BLE		2.4 GHz
Indicators			5 × LEDs
Compliance			
Safety			IEC 61439-1/-2
Health			IEC 62311
EMC			EN 301 489-1/-17, IEC 61000-6-1/-3
Radio spectrum			EN 300 328
PLC			EN 50065-1/-2

a. The standard configuration of the PV-side breaker is 20A, which can be replaced with a 25A / 32A rated circuit breaker, supporting a maximum of 30kW.

b. Refer to the local electrical regulations to select the cable size.

Appendix 1: Recommended wire diameter

Depending on the quantity and installation method of the batteries, the recommended wire diameter for the power cables is as follows:

a. When the M- ELV battery is used in single-phase mode

Number of sets	Max. Current (A)	Recommendation wire diameter (mm ²)
1	23.8	4 mm ²
2	47.6	10 mm ²
3	50	10 mm ²
4	50	10 mm ²
5	50	10 mm ²
6	50	10 mm ²

b. When the M- ELV battery is used in three-phase mode

Number of sets	Max. Current (A)	Recommendation wire diameter (mm ²)
1	7.9	2.5 mm ²
2	15.9	2.5 mm ²
3	23.9	4 mm ²
4	31.9	6 mm ²
5	39.9	10 mm ²
6	47.9	10 mm ²

NOTE:

- The wire diameter can be adjusted according to local regulations and installation conditions.
- The cable must use copper core cable with a maximum allowable operating temperature of no less than 90°C.

Appendix 2: Terms and Abbreviations

AC	Alternating current
APP	Application
.....	
CAT 6	Category 6
.....	
DC	Direct current
DI	Digital input
DO	Digital output
.....	
EMC	Udcstart, V
ETH	Idcmax, A
.....	
MPPT	Maximum power point tracking
.....	
PE	Protective earthing
PV	Photovoltaic
RH	Relative humidity
.....	
SN	Serial number
WEEE	Waste electrical and electronic equipment

ATMOCE

Contact Details

Company: ATMOCE Holding B.V.
Address: Rokin 92-96, 1012 KZ Amsterdam, the Netherlands
Email: support@atmoce.com
Telephone: +31 20 241 6207

Copyright © Atmoce Holding B.V. 2026. All rights reserved.

No parts of this document may be reproduced or transmitted in any form or by any means without the prior written consent of Atmoce Holding B.V.

Trademark Notice

ATMOCE Atmoce is trademark or registered trademark of Atmoce Holding B.V.

Other trademarks, product names, services, and company names mentioned are the property of their respective owners.

General Disclaimer

The information in this document may contain predictive statements, including, without limitation, statements regarding future financial and operational results, future product portfolios, new technologies, etc. There are a number of factors that could cause actual results and developments to differ materially from those expressed or implied in the predictive statements. Therefore, such information is provided for reference purposes only and constitutes neither an offer nor an acceptance. Atmoce may change the information at any time without notice.